

Functionality-aware Retargeting of Mechanisms to 3D Shapes

Ran Zhang¹ Thomas Auzinger¹ Duygu Ceylan² Wilmot Li² Bernd Bickel¹

¹IST Austria ²Adobe Research



Motivation

Functional objects design



CNC



Laser cutting



Architecture

Motivation

Functional objects design

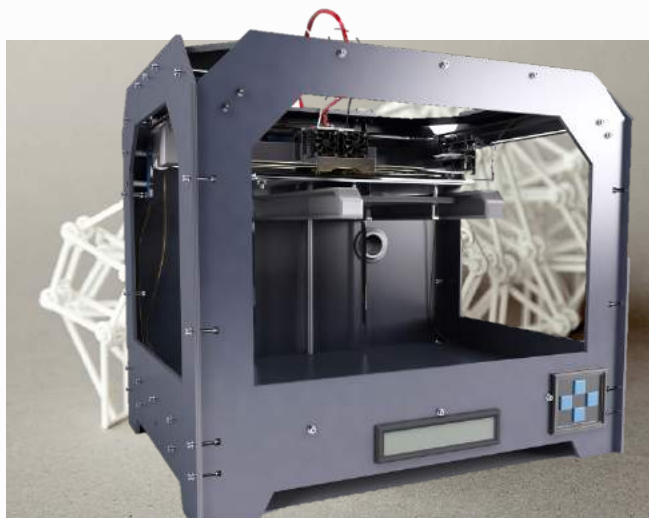

Motivation

Functional objects design

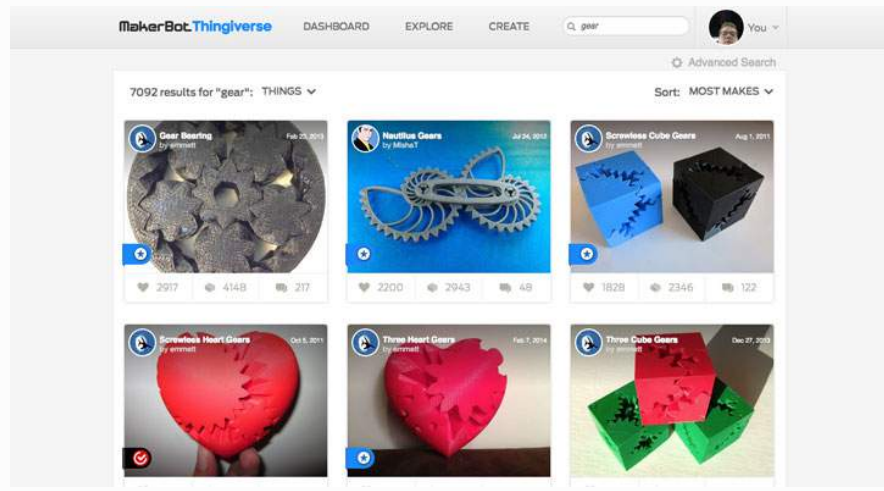

Thingivers

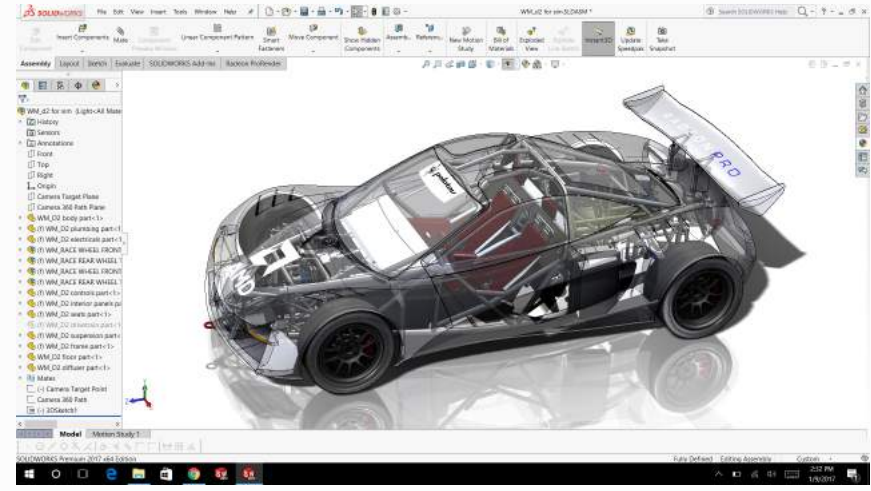

Solidworks

Motivation

Function vs form

“Form follows function”

-Louis Sullivan

Motivation

Reusing underlying structure



Motivation

Problems

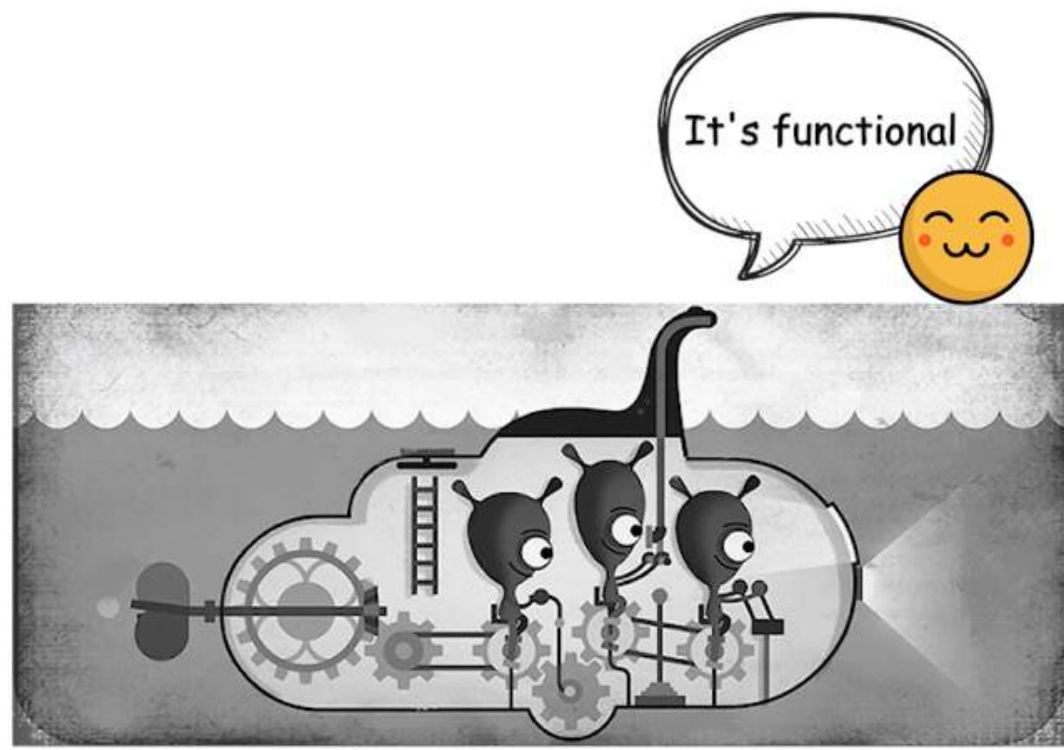

Motivation

Problems

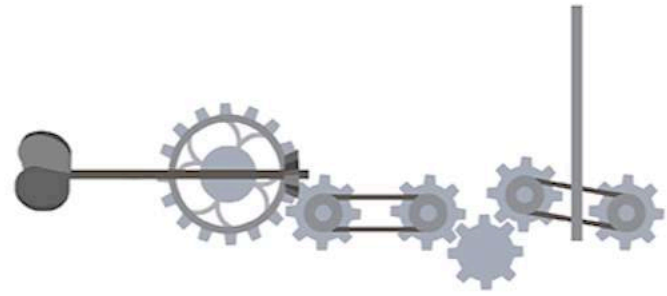

Motivation

Retargeting problem

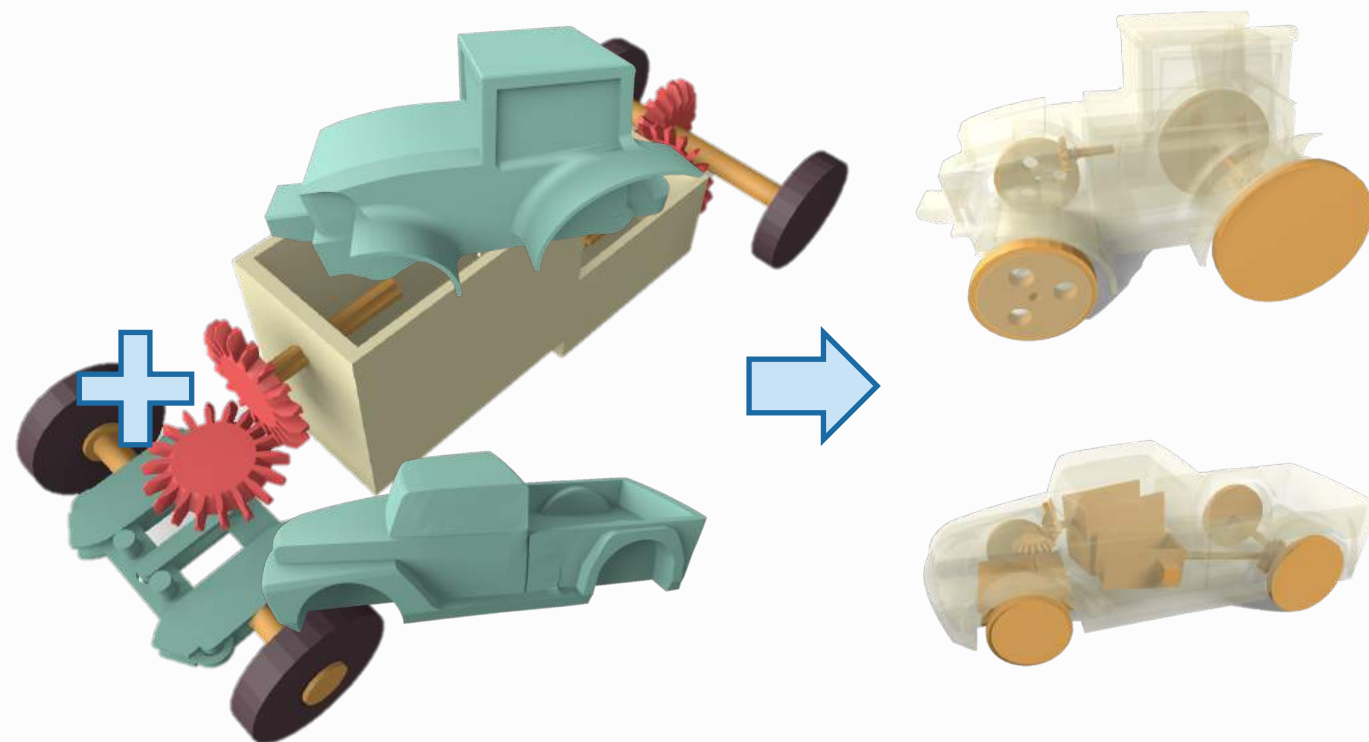

Motivation

Challenges

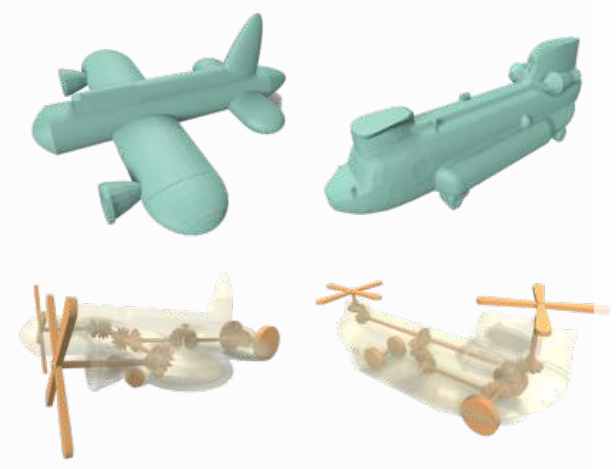

Configuration

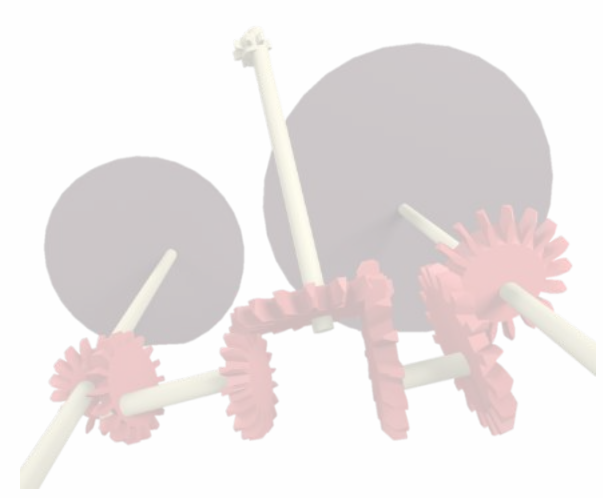

Functionality

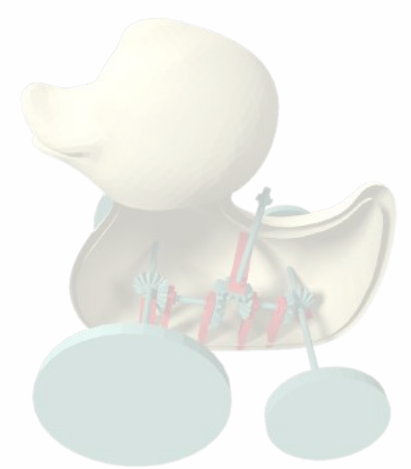

Fabrication

Motivation

Challenges



Configuration

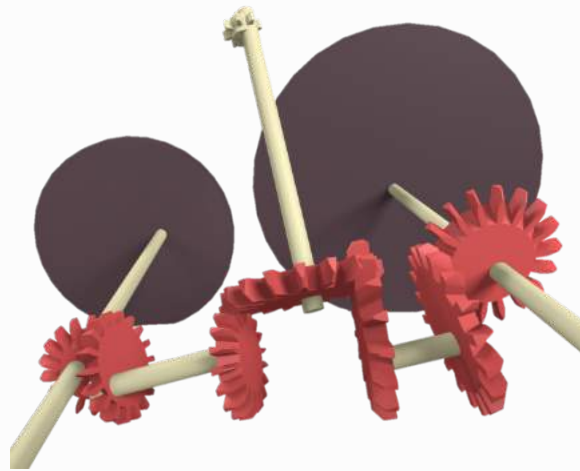

Functionality

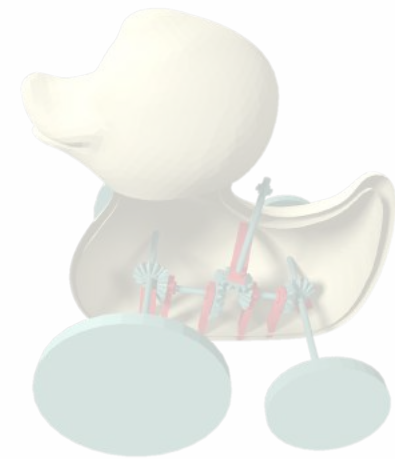

Fabrication

Motivation

Challenges

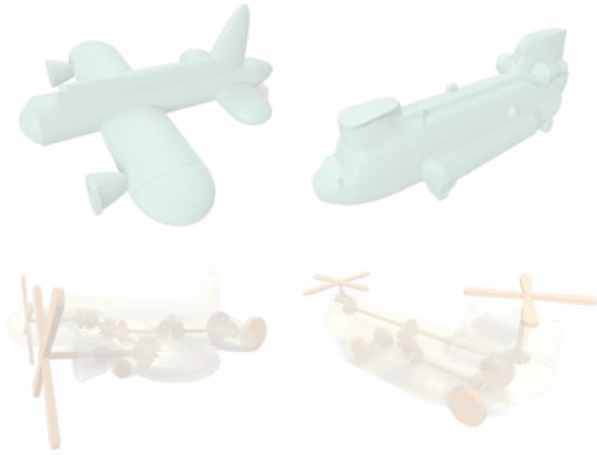

Configuration

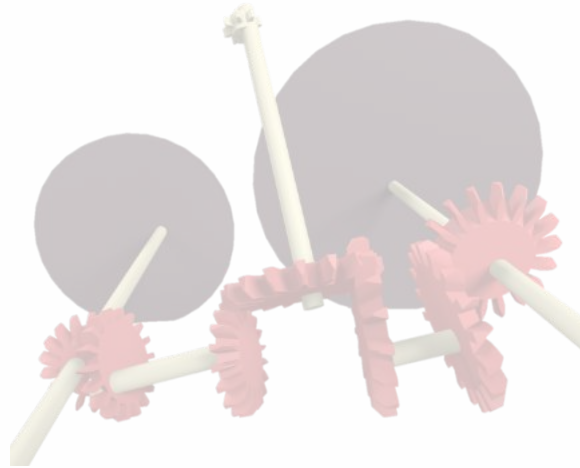

Functionality

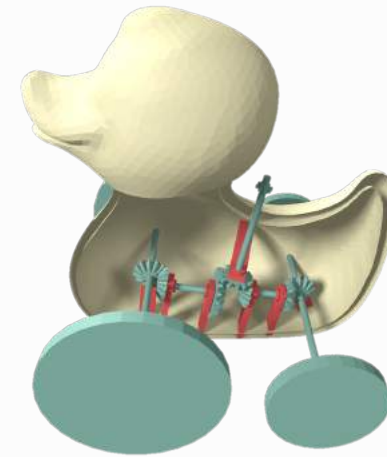

Fabrication

Related work

Traditional design workflow

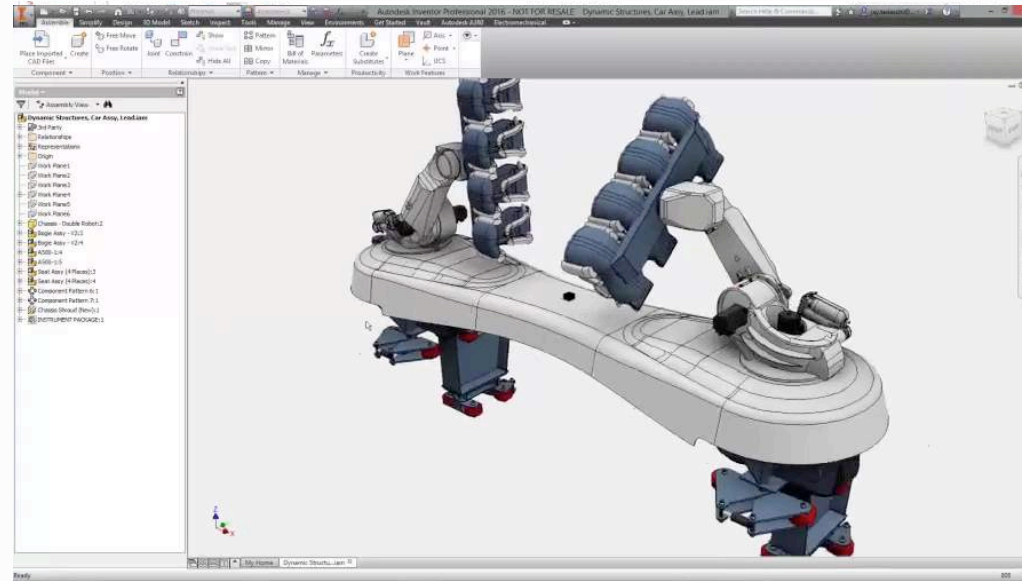

[Solidworks]

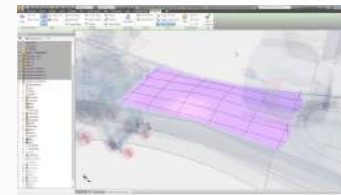

[Inventor]

Related work

Computational mechanism design

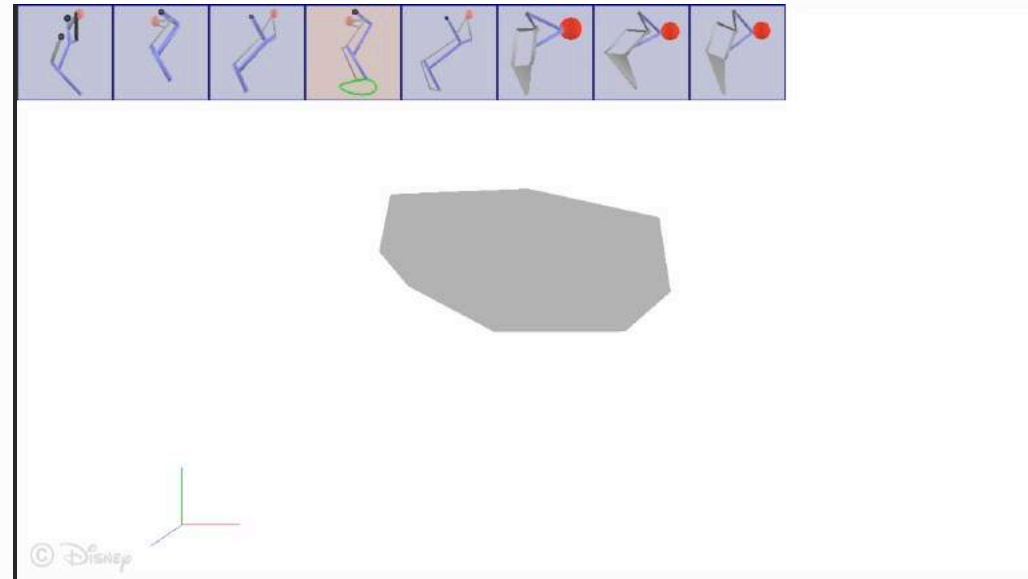

[Zhu, et al. 2012]



[Coros, et al. 2013]

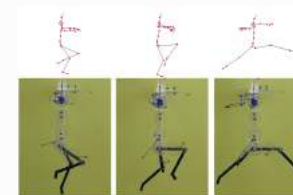

[Ceylan, et al. 2013]



[Bharaj, et al. 2015]

Related work

Example based modeling

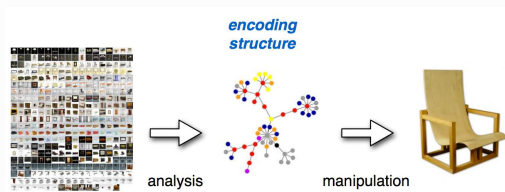
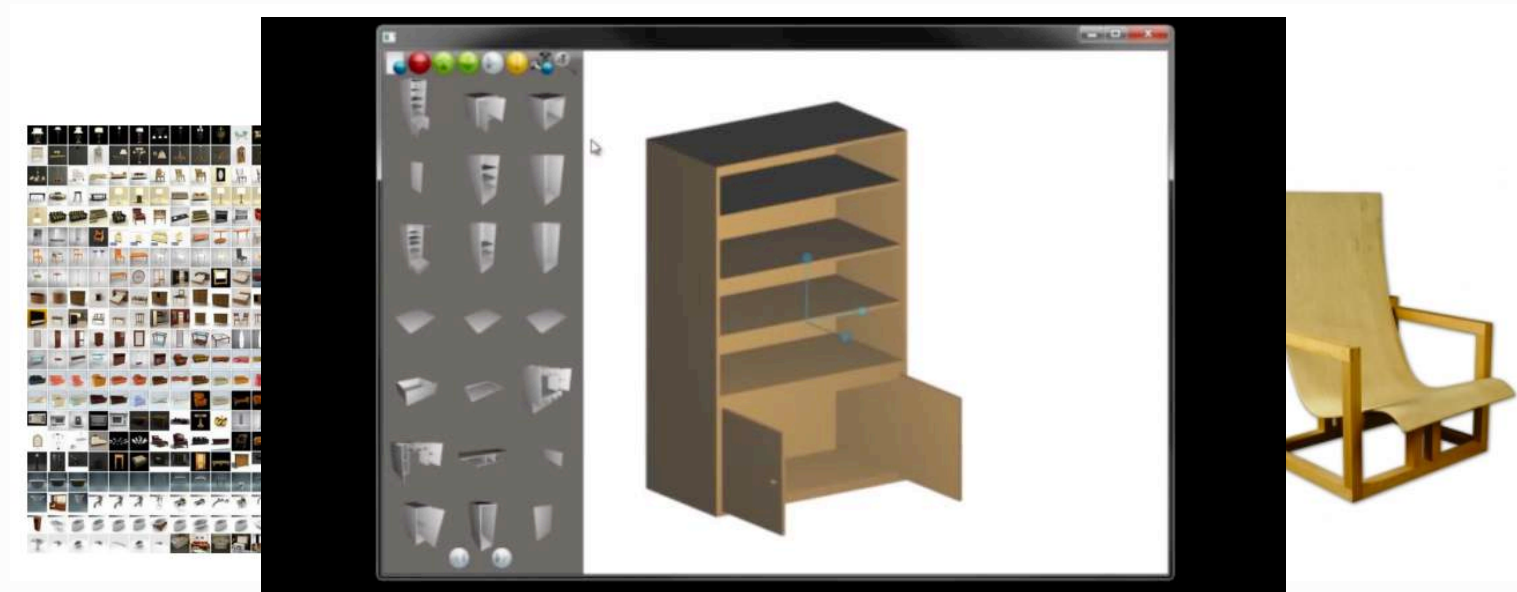

[Mitra, et al. 2014]

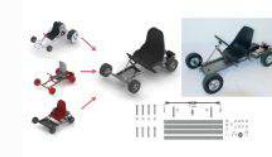

[Schulz, et al. 2015]

Related work

Constraint-based editing

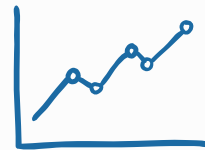
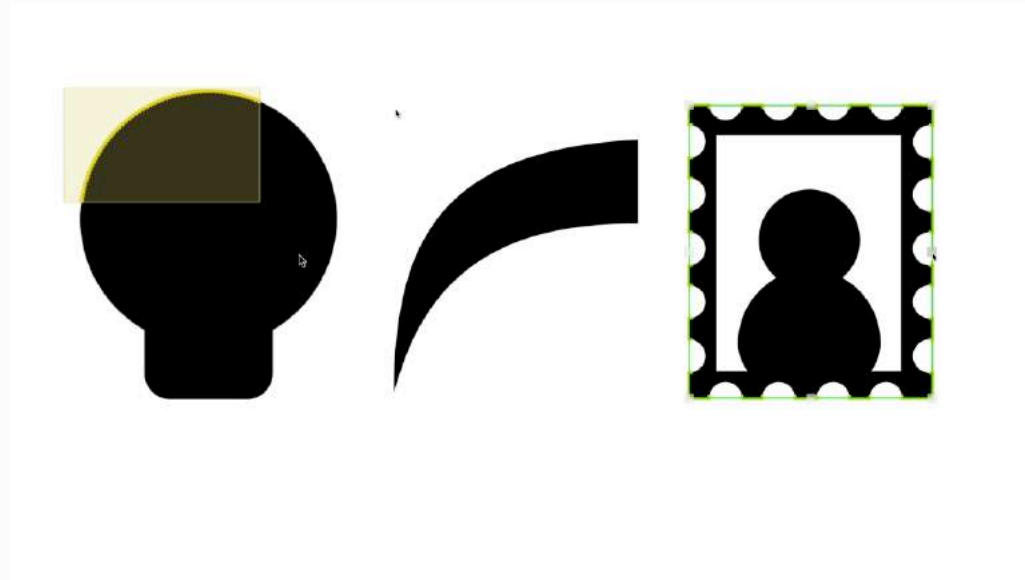

[Bächer, et al. 2015]

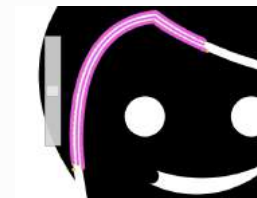

[Bernstein, et al. 2013]

Pipeline

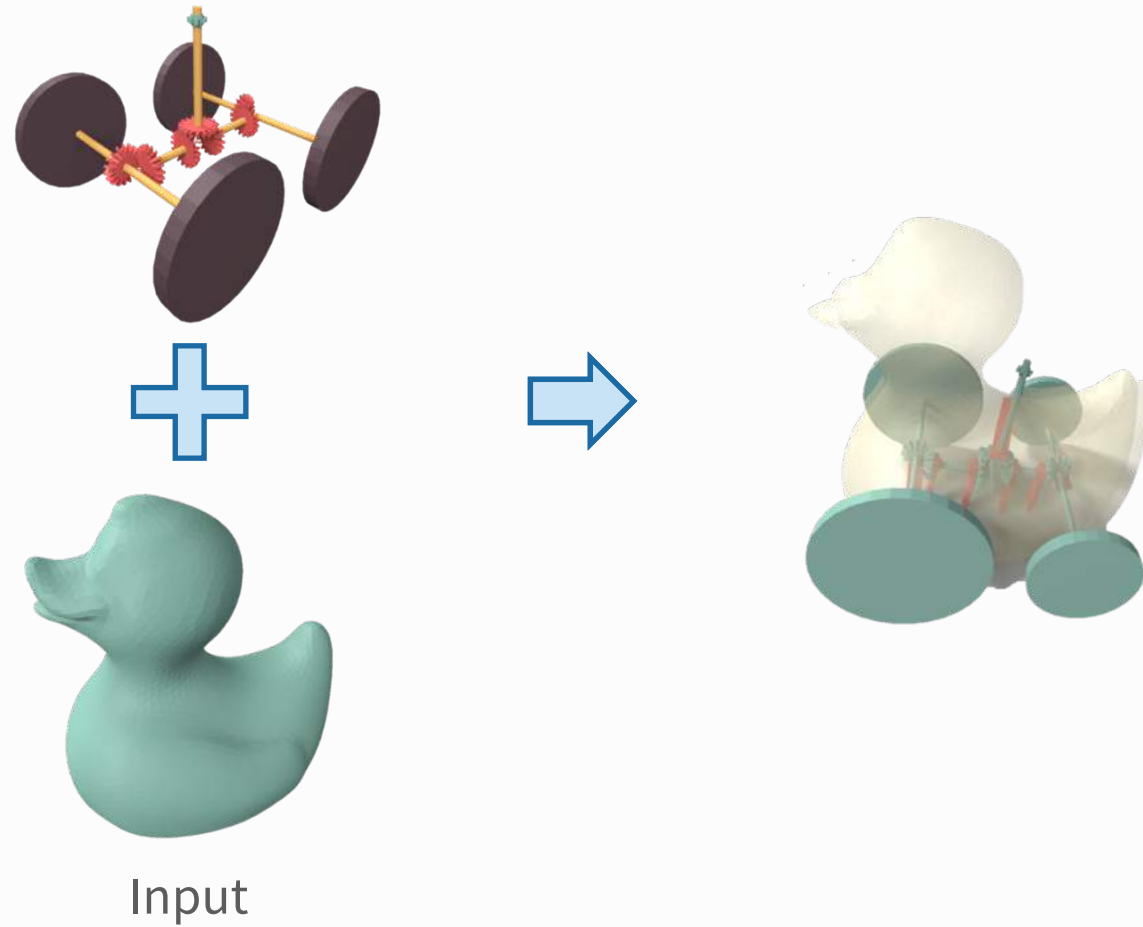

Pipeline

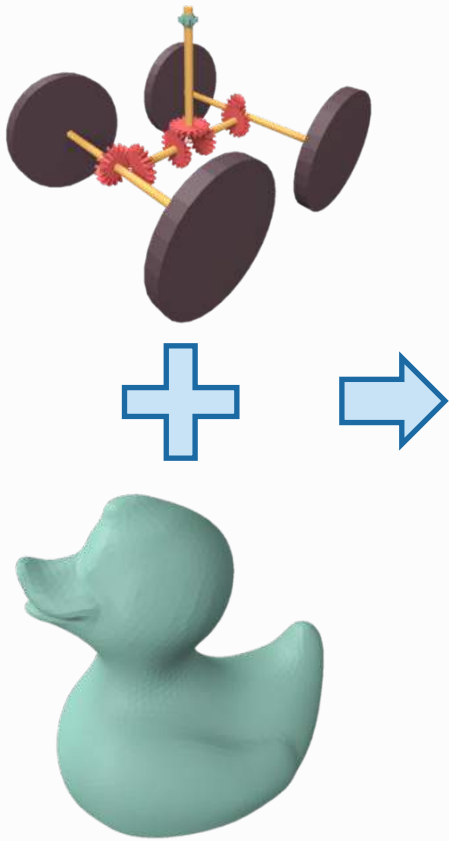

Input



Interactive design system

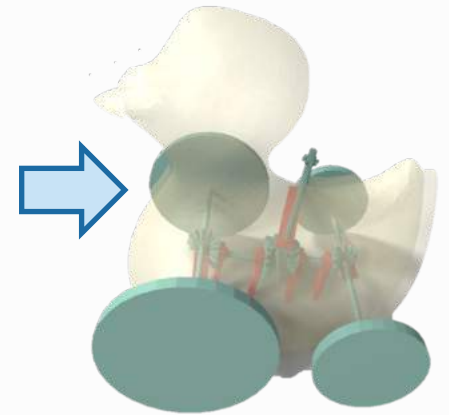

Output

Pipeline

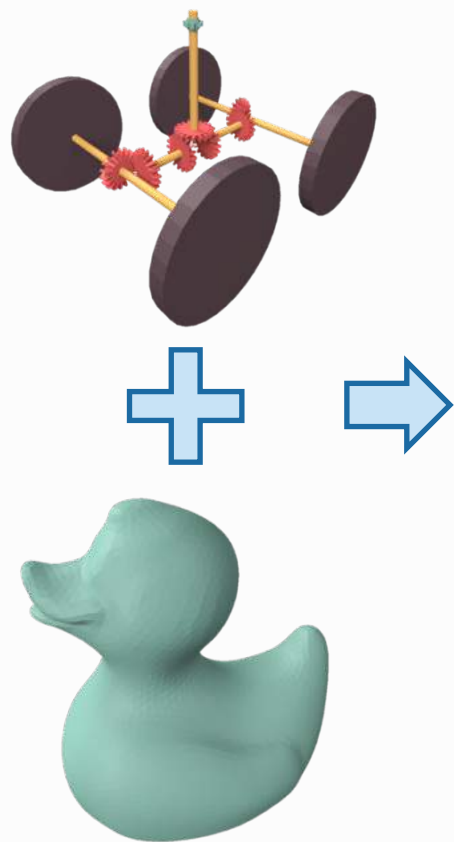

Input



Optimization

Post processing

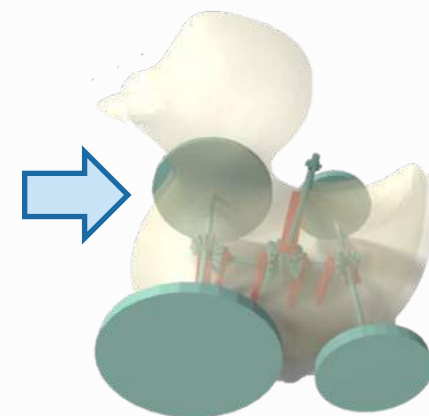

Output

Pipeline

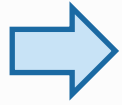
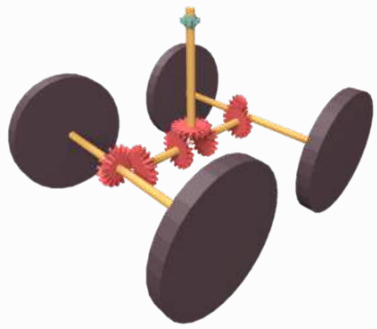

Input

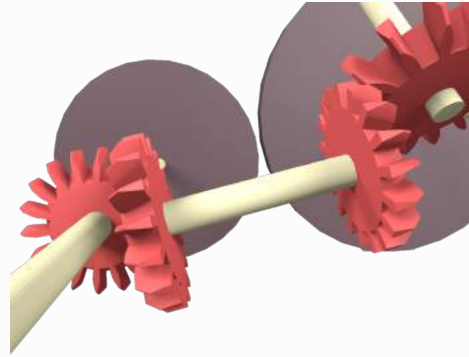

Optimization

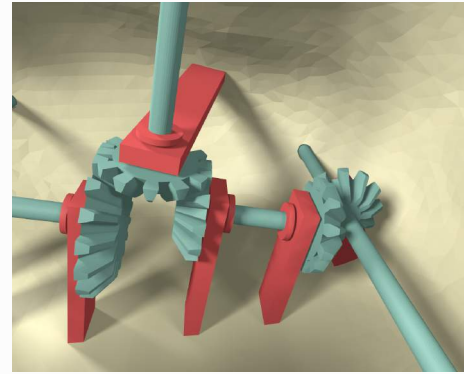

Post processing

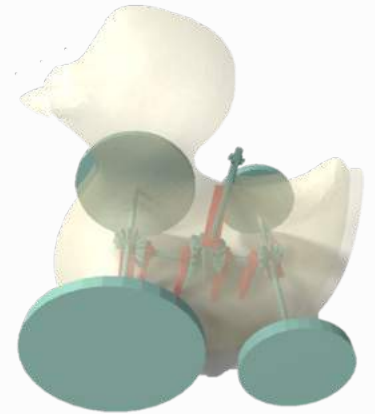
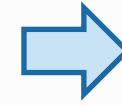

Output

Pipeline

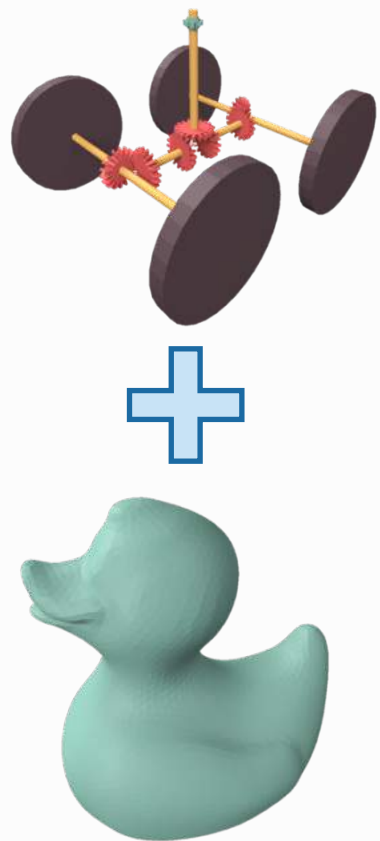

Input

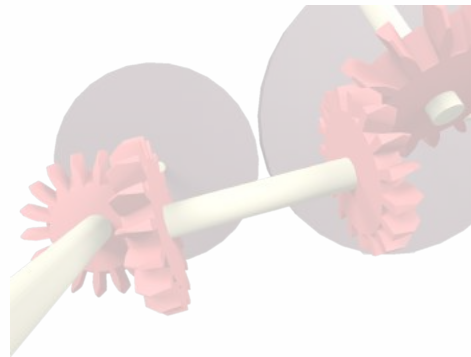

Optimization

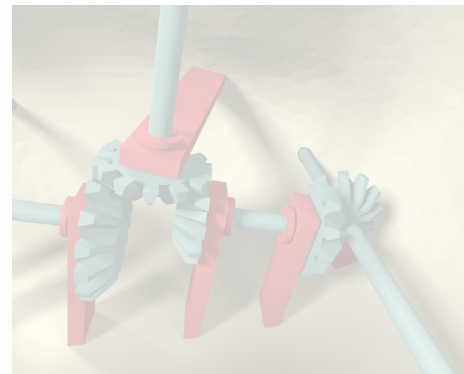

Post processing

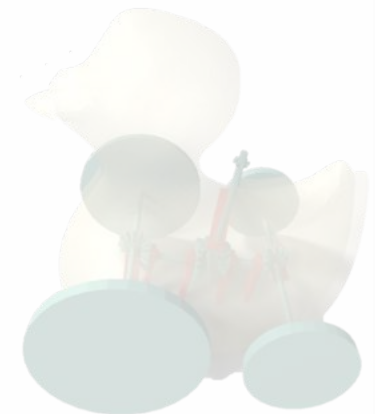

Output

Template

Inputs

Templates

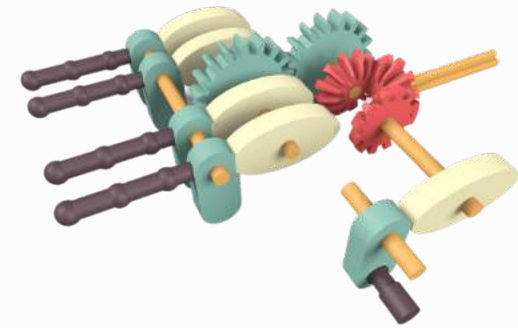
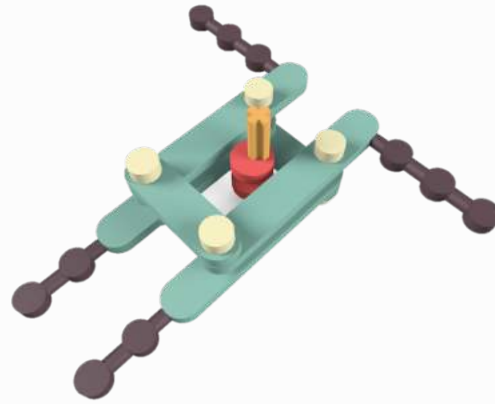
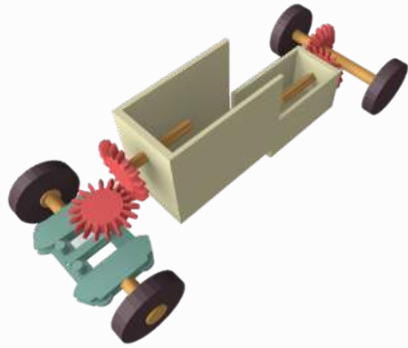

Target shapes

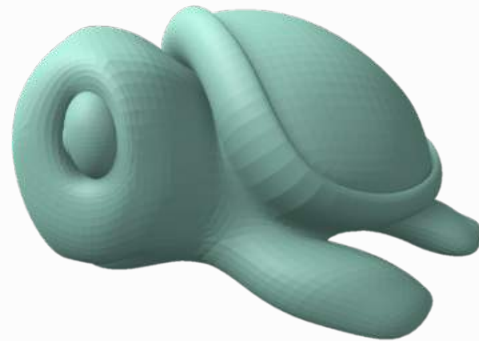
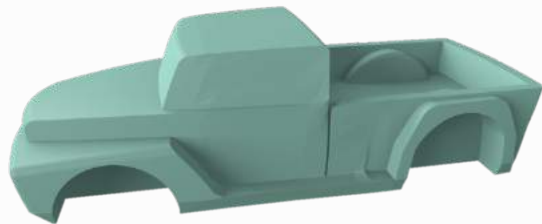

Template

Parsing process

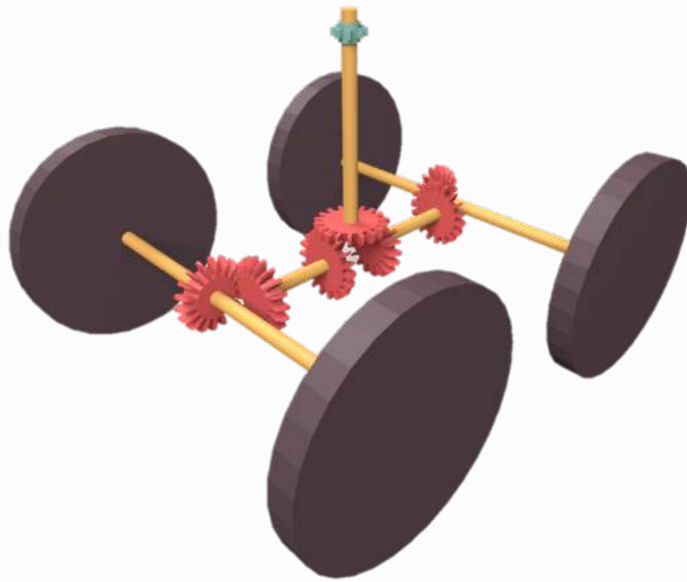

Template

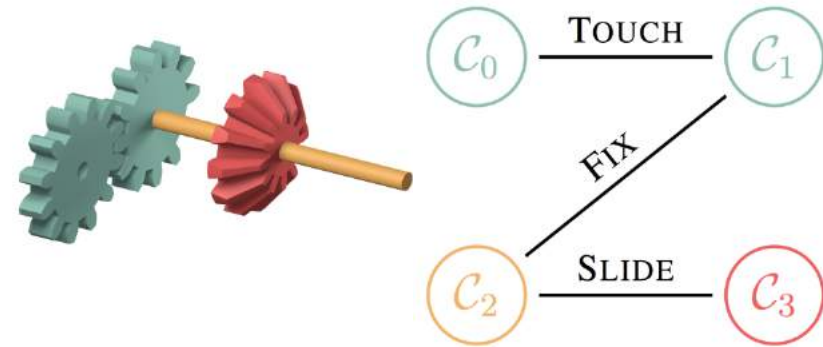
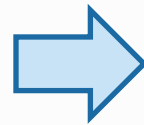

Components and connections

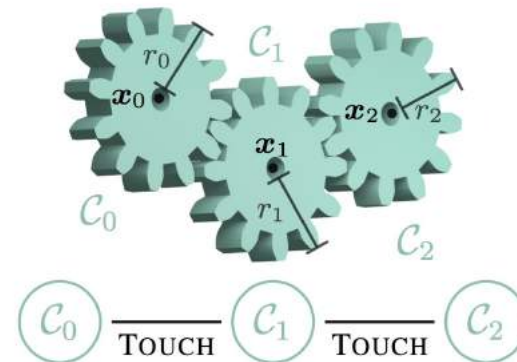

Constraints

Constraints

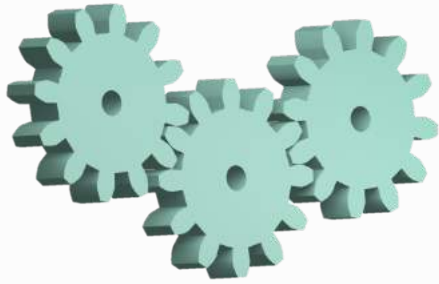

Mechanical constraints

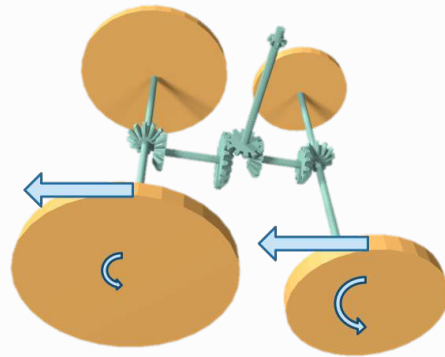

Functional constraints

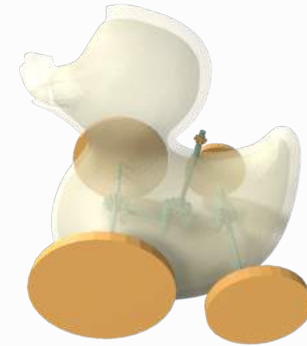

Spatial constraints

Constraints

Mechanical constraints

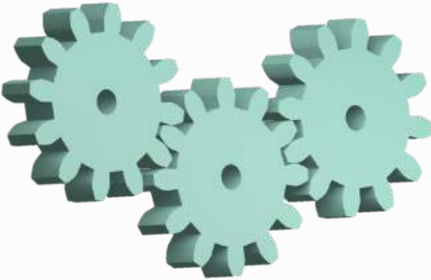

Mechanical constraints

A diagram illustrating functional and spatial constraints. On the left, a mechanism with orange circular components and grey connecting rods is shown. Blue arrows indicate the direction of movement or force, and curved arrows indicate rotation. On the right, a white, bird-like object is shown with orange circular components positioned near its base, illustrating spatial constraints. The entire diagram is enclosed in a light grey border with vertical dashed lines separating the two parts.

Functional constraints

Spatial constraints

Constraints

Mechanical constraints

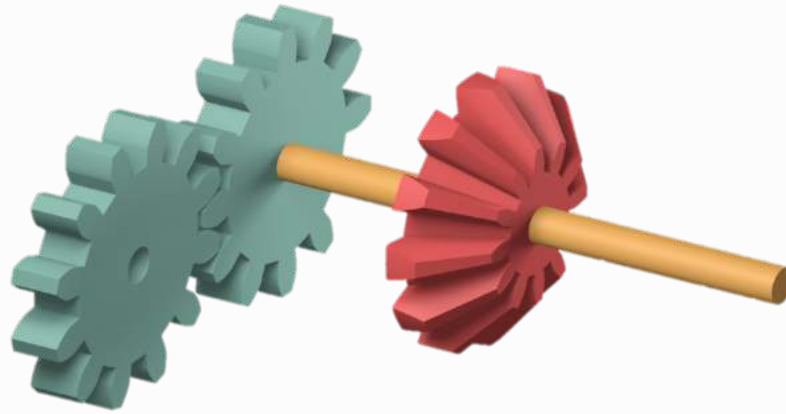

Constraints

Mechanical constraints

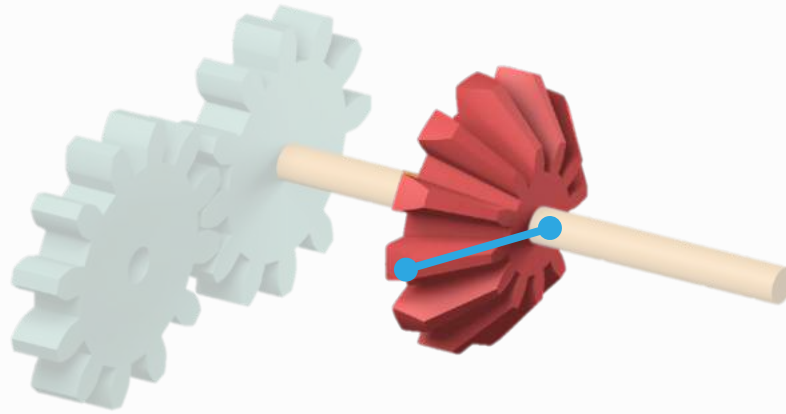

Unary constraints

Constraints

Mechanical constraints

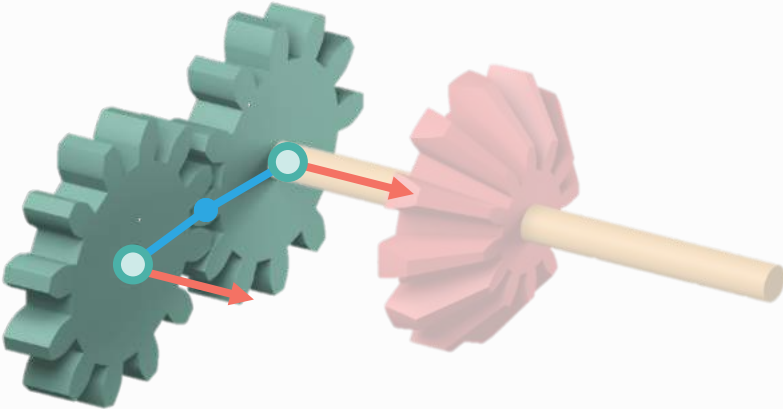

Binary constraints

Constraints

Functional constraints

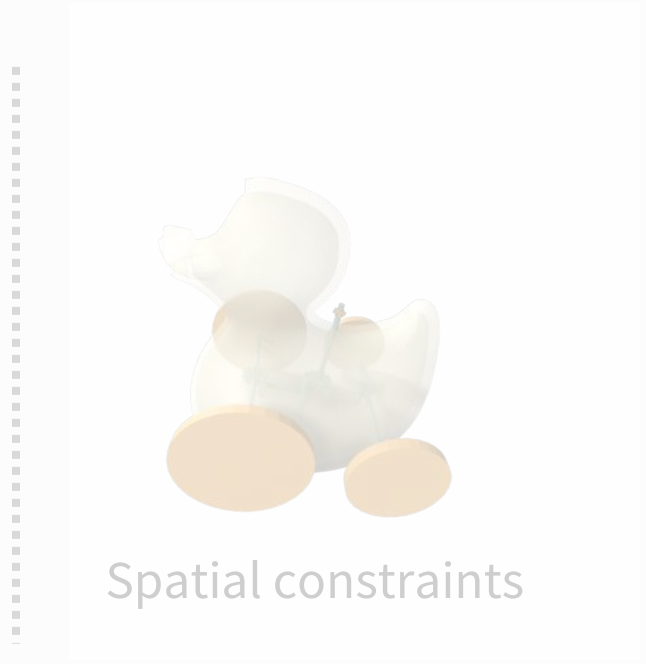
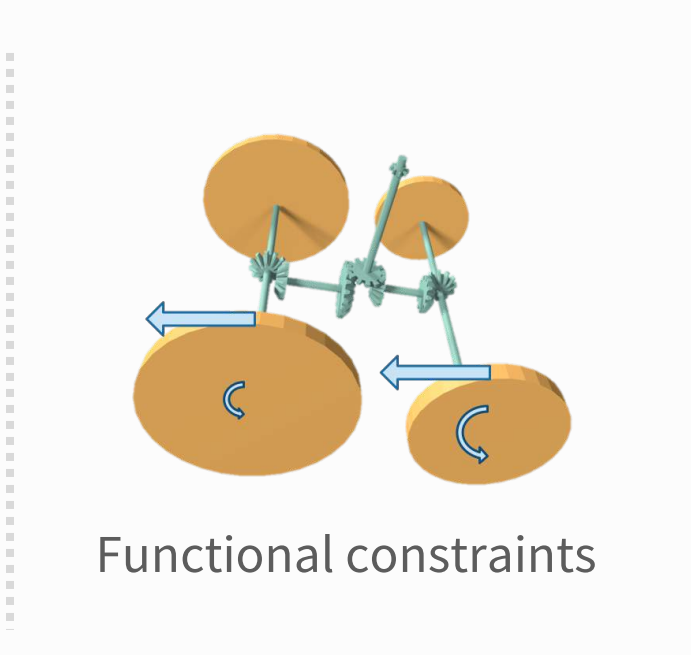
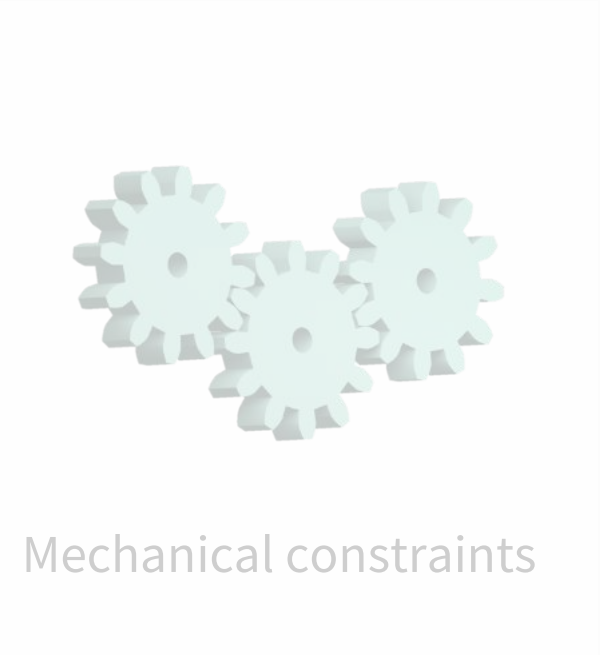

Constraints

Functional constraints

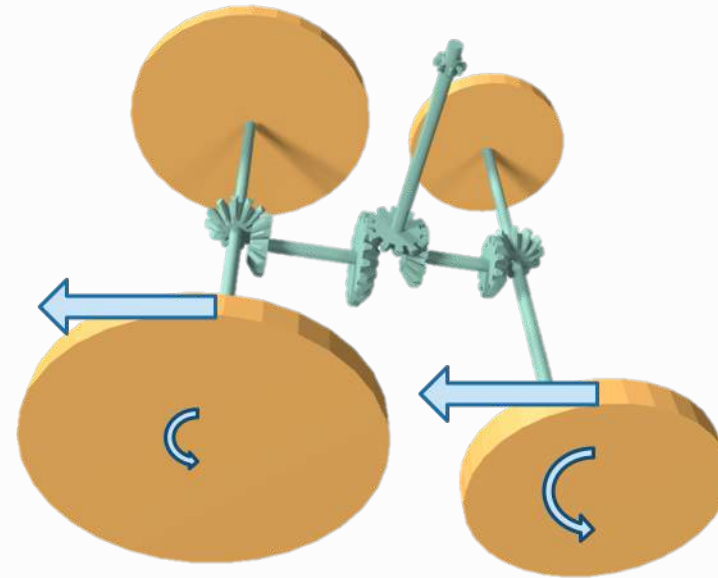

Linear speed constraints

Constraints

Spatial constraints

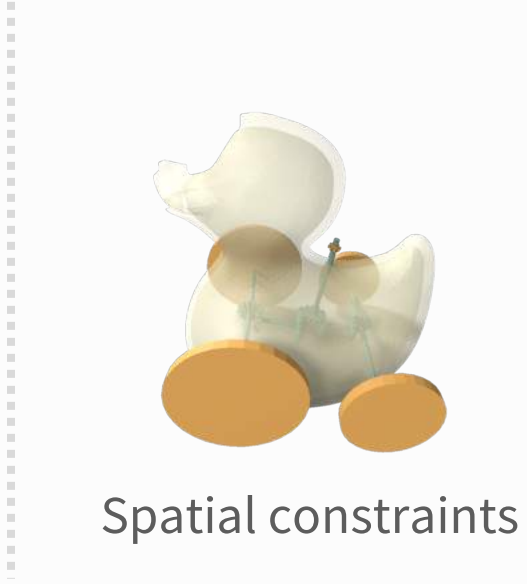
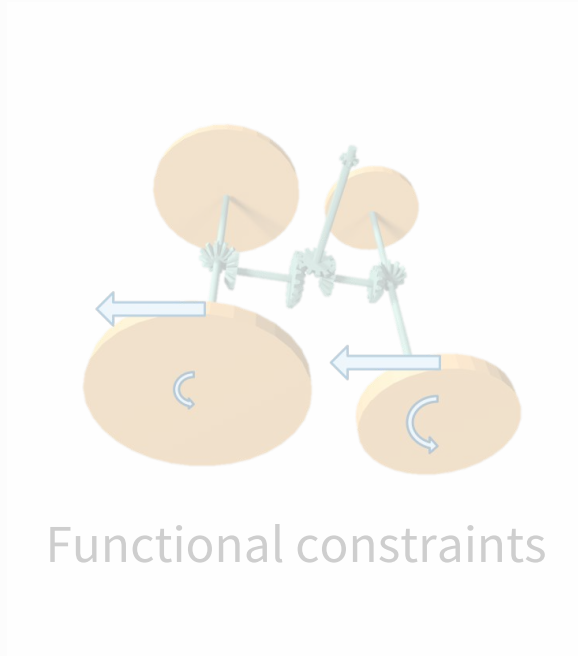
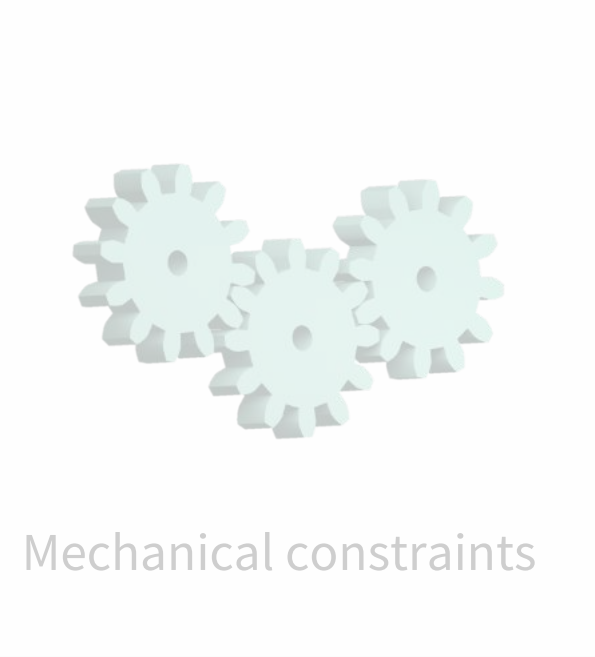

Constraints

Spatial constraints

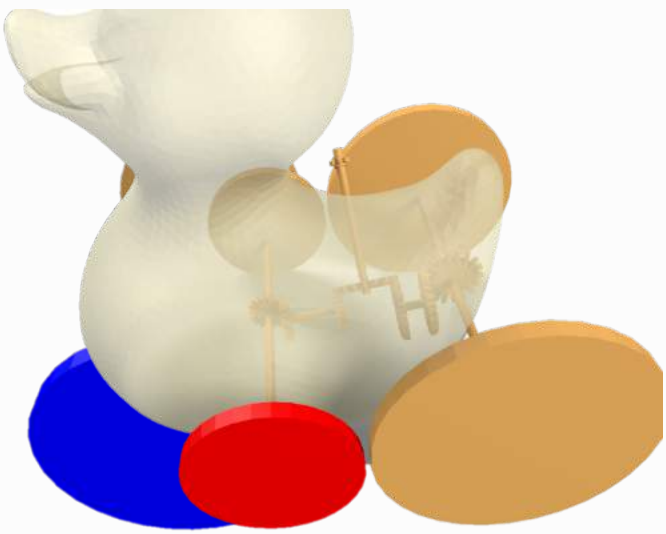

User placement constraints

Constraints

Spatial constraints

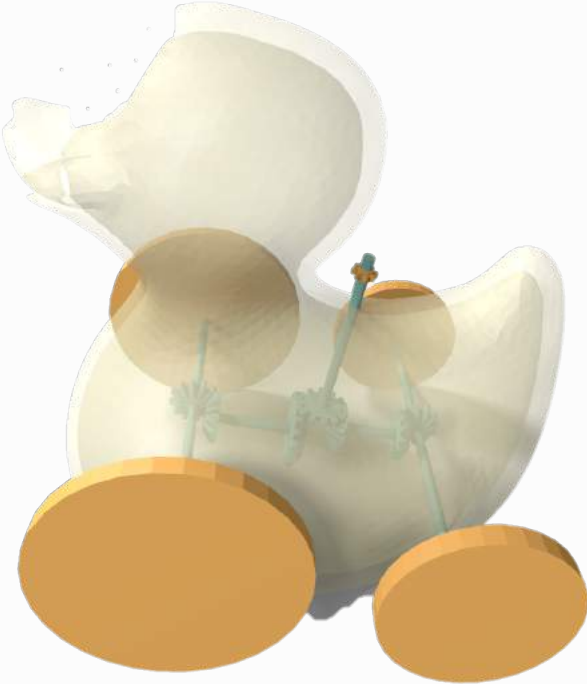

Containment constraints

Constraints

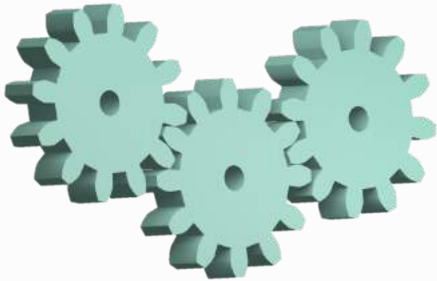

Mechanical constraints

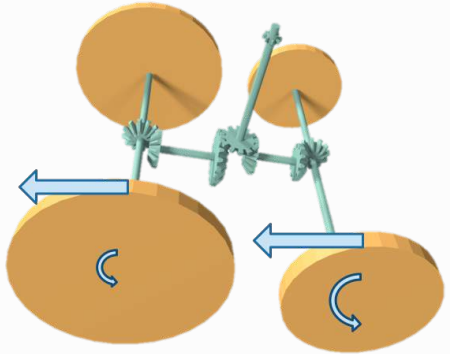

Functional Constraints

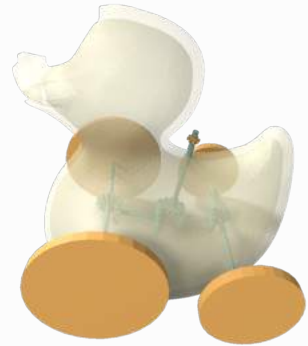

Spatial constraints

Constraints

$$E_{mech} \geq 0$$

$$E_{func} \geq 0$$

$$E_{spatial} \geq 0$$



Hard constraints



Soft constraints

Pipeline

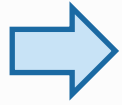
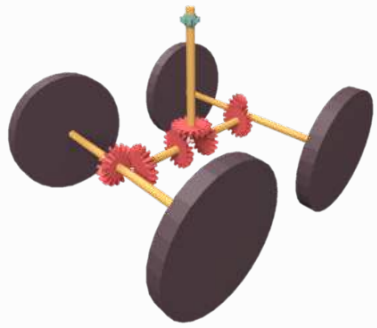

Input

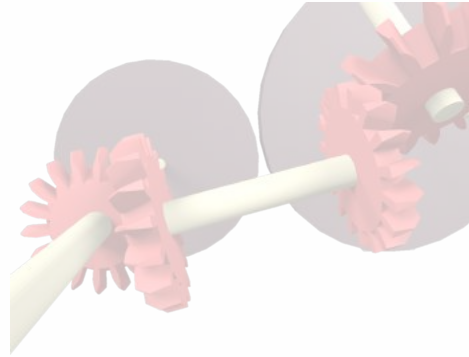

Optimization

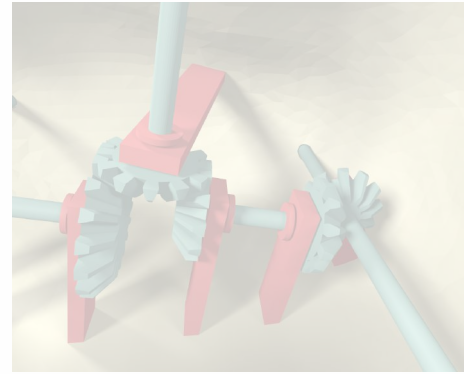

Post processing

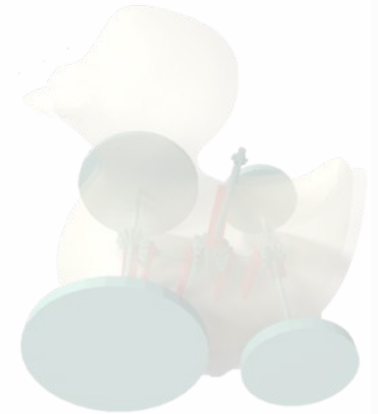
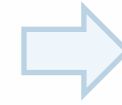

Output

Pipeline

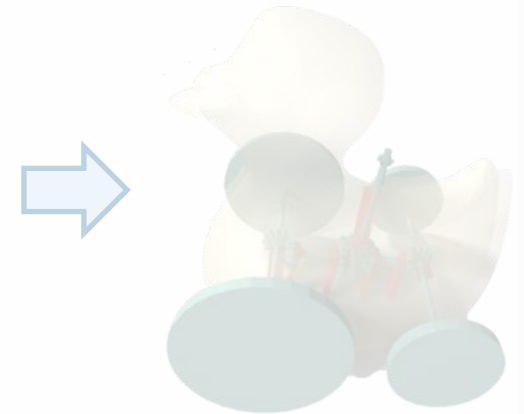
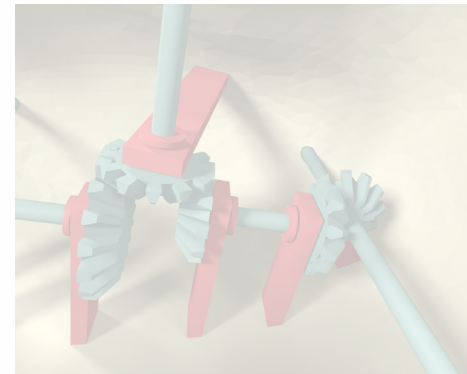
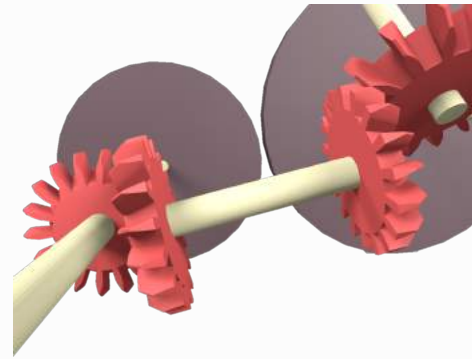
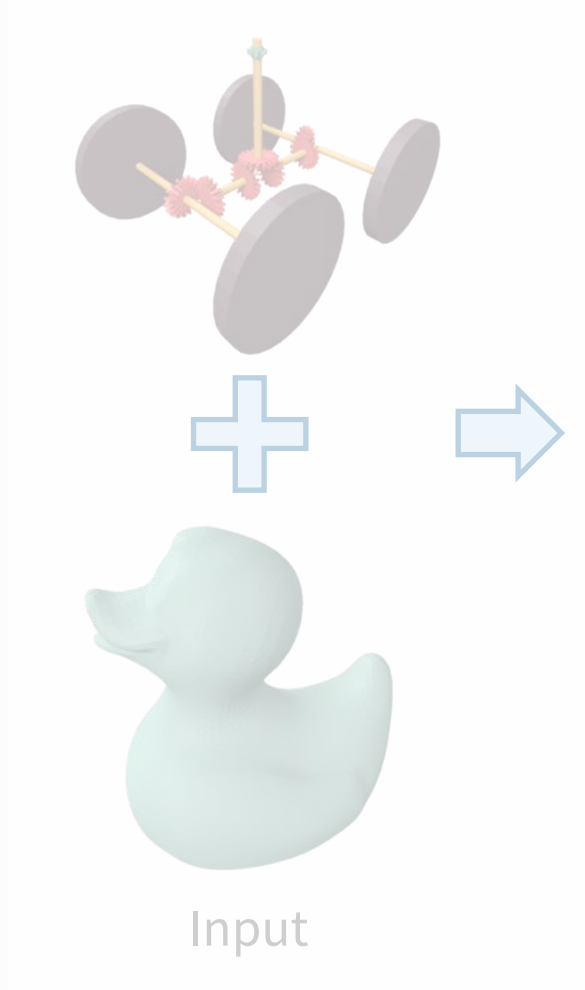

Optimization

Formulation

$$E_{mech} \geq 0$$

$$E_{func} \geq 0$$

$$E_{spatial} \geq 0$$



Hard constraints



Soft constraints

Optimization

Formulation

$$\operatorname{argmin}_p E_{spatial}$$

$$\text{s.t. } E_{mech}, E_{func}$$

$$E_{mech}$$

$$E_{func}$$



Hard constraints

$$E_{spatial}$$



Soft constraints

Optimization

Differential manipulation

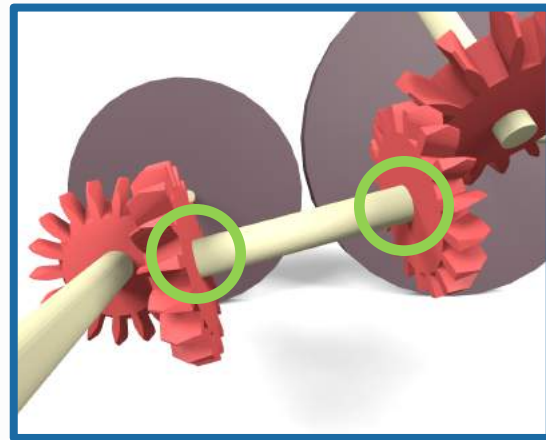
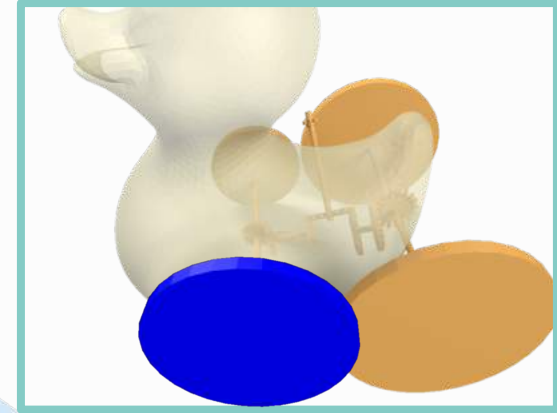
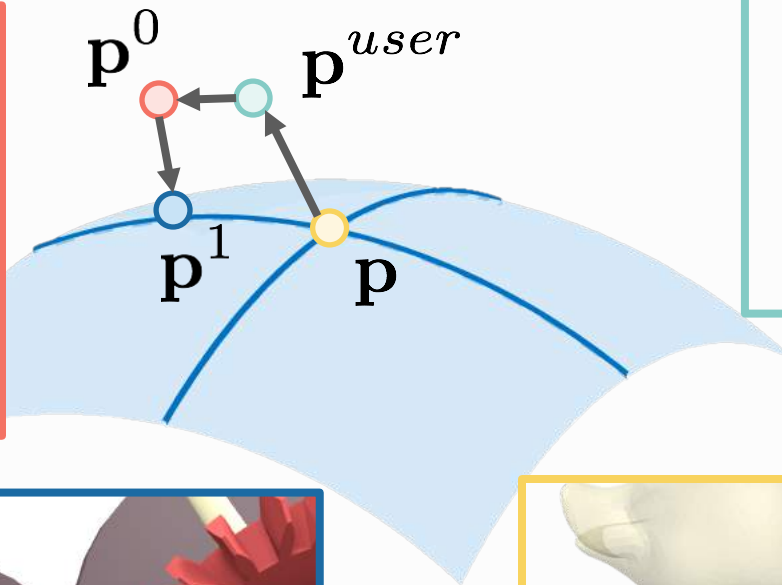
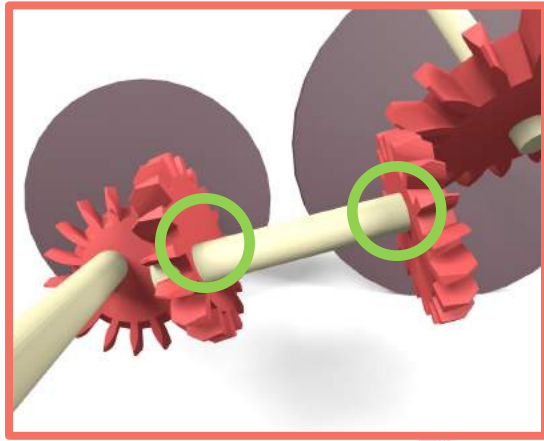

Optimization

User interaction

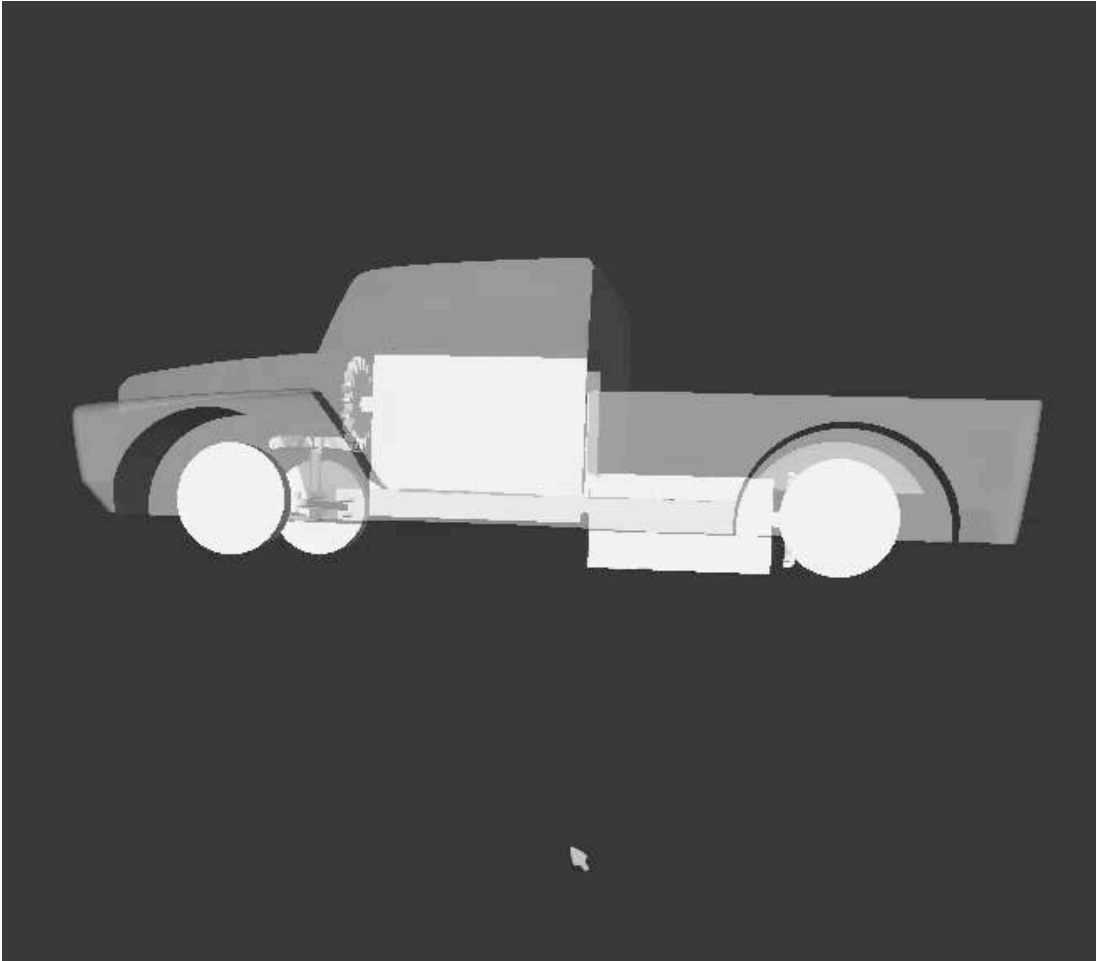

Pipeline

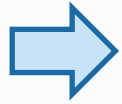
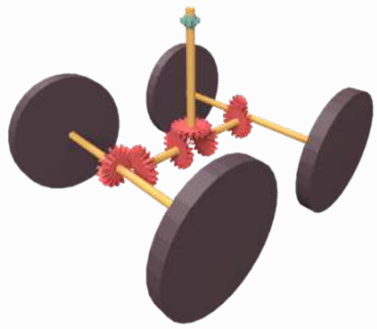

Input

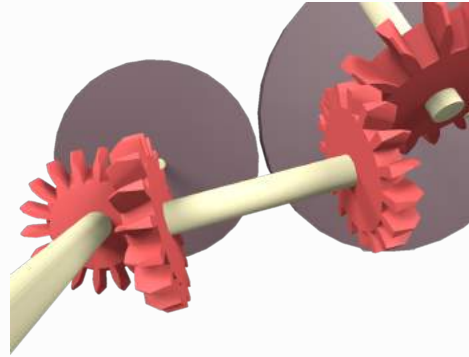

Optimization

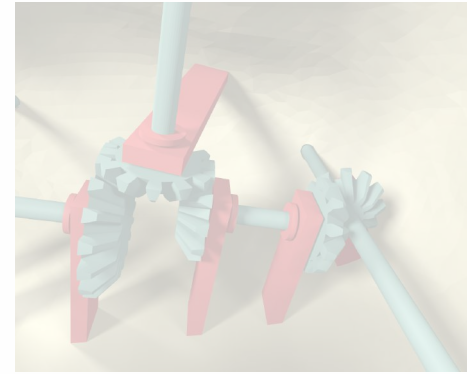

Post processing

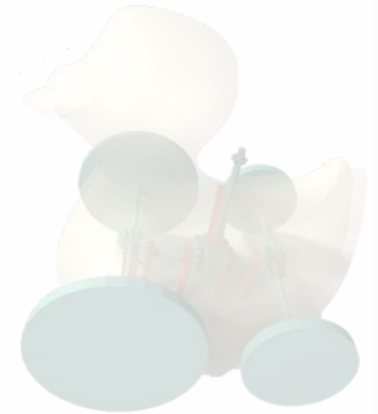
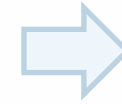

Output

Pipeline



Input

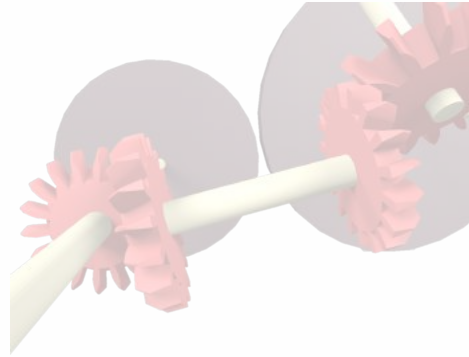
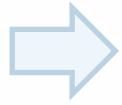

Optimization

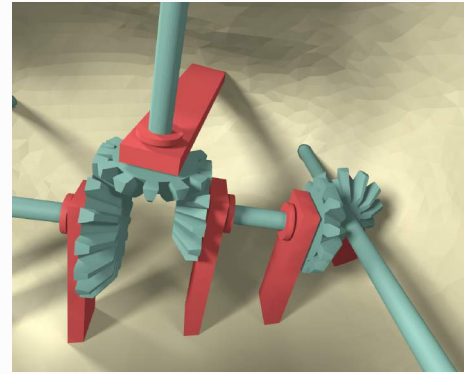

Post processing

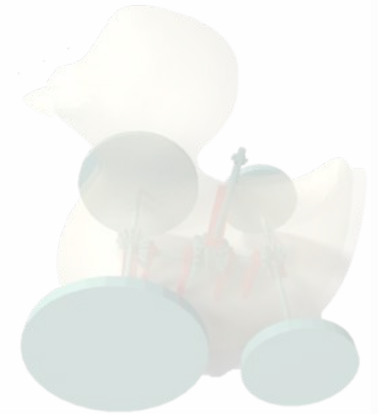
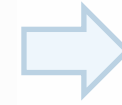

Output

Post processing

Fixations

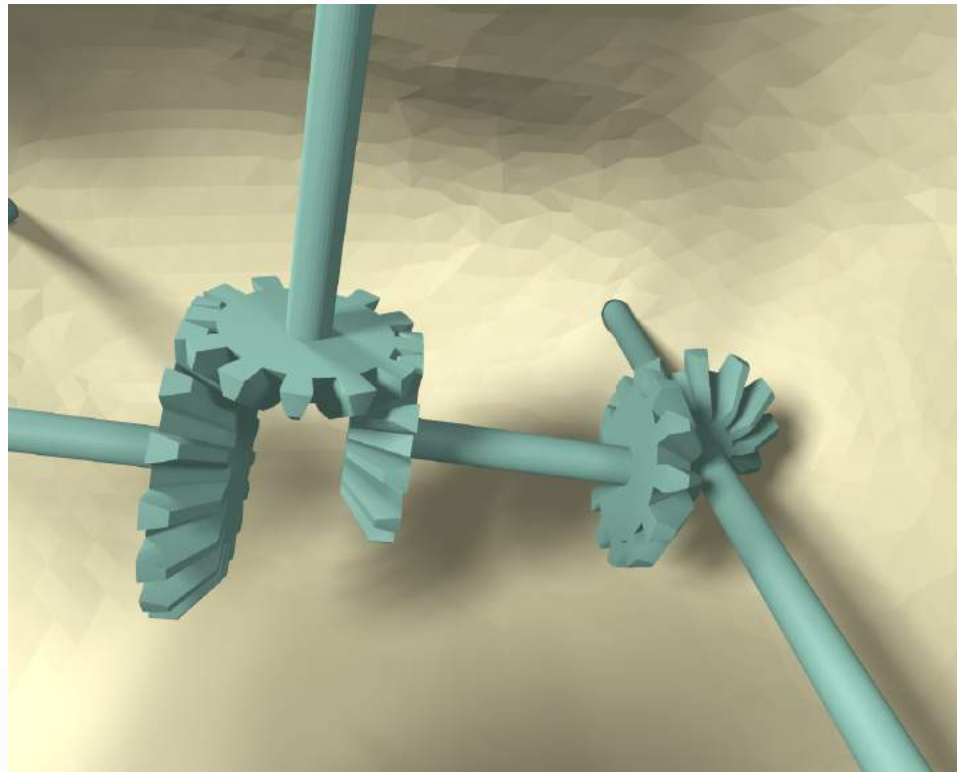

Post processing

Fixations

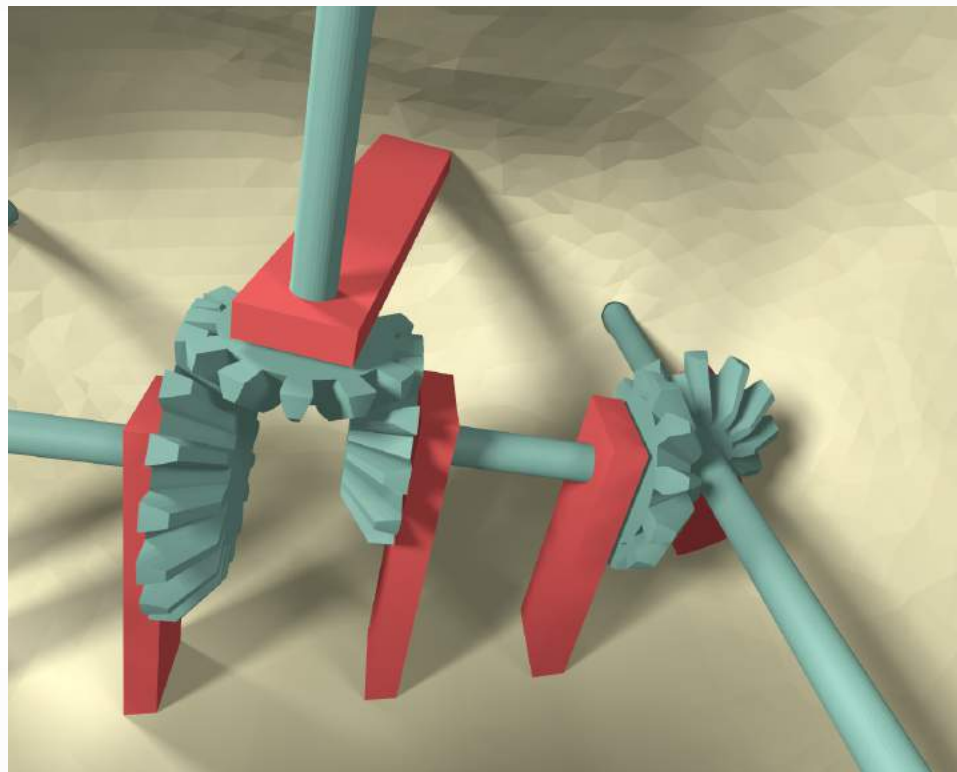

Post processing

Fixations

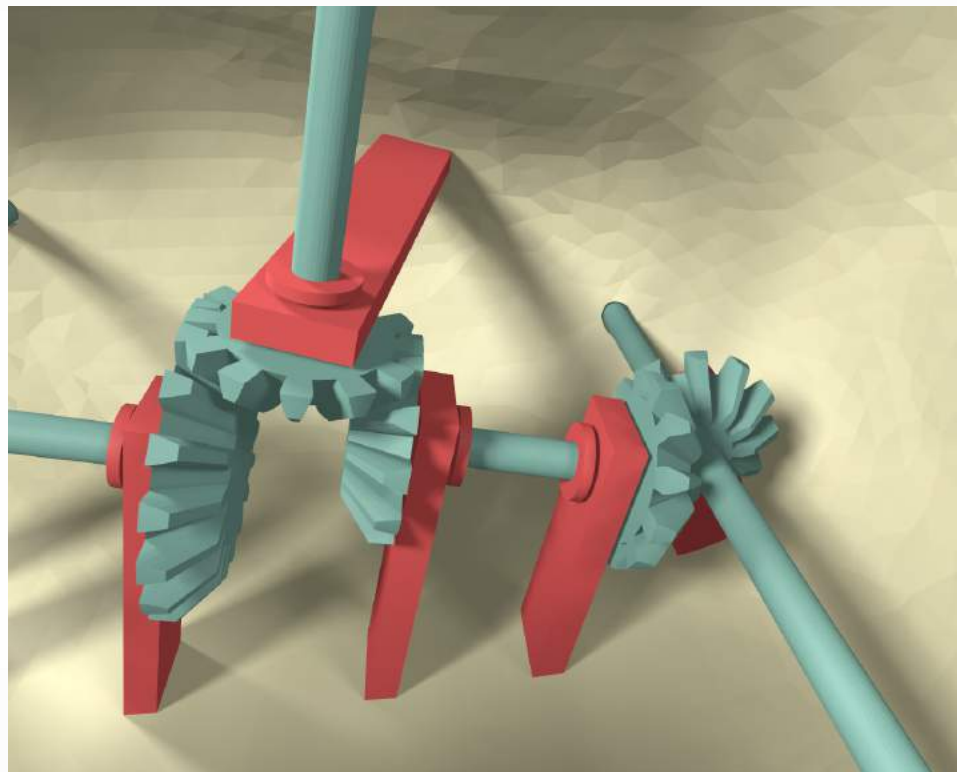

Post processing

Cutaways



Pipeline

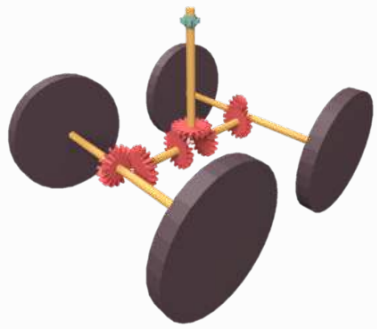

Input

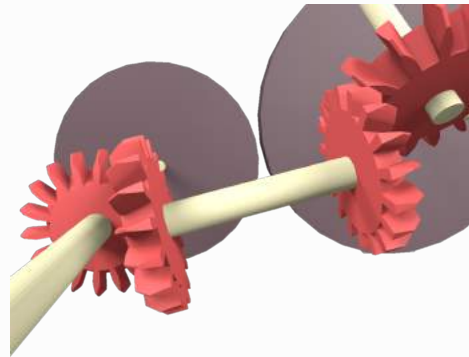

Optimization

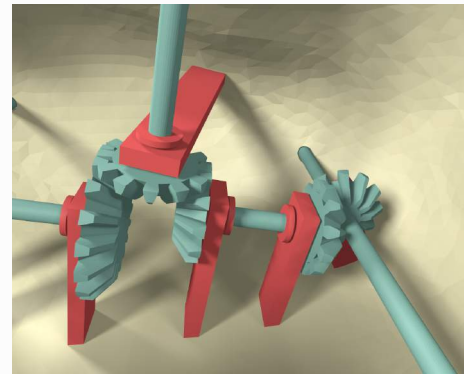

Post processing

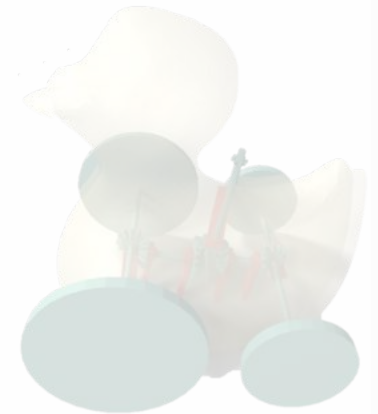
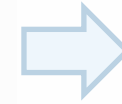

Output

Pipeline



Input

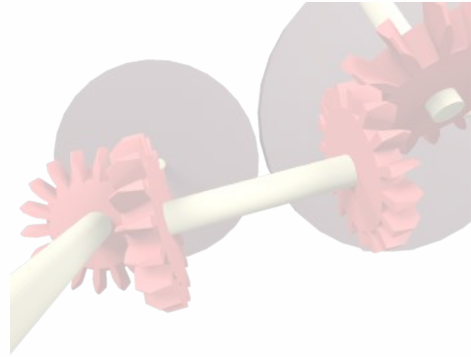
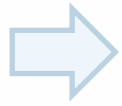

Optimization

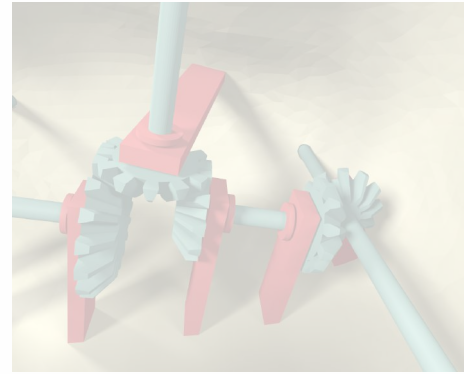

Post processing

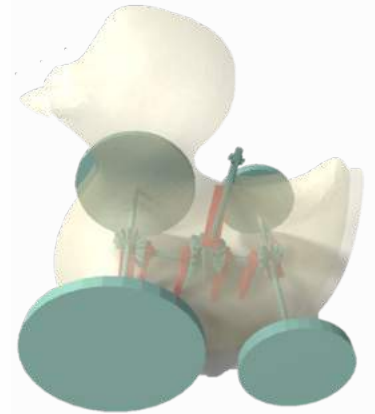
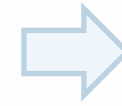

Output

Printing

Hooray!



Results

Drivetrain

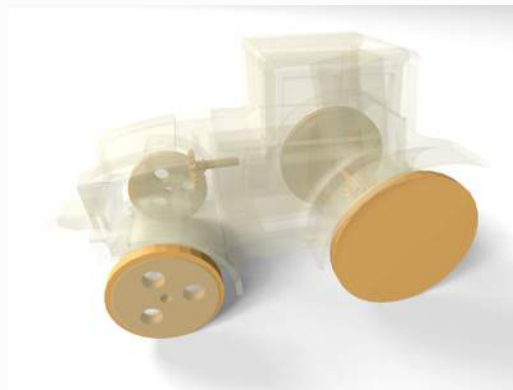
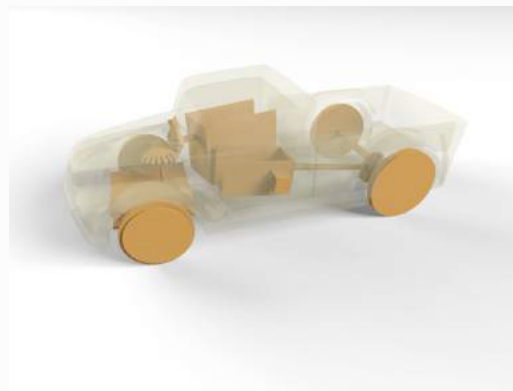
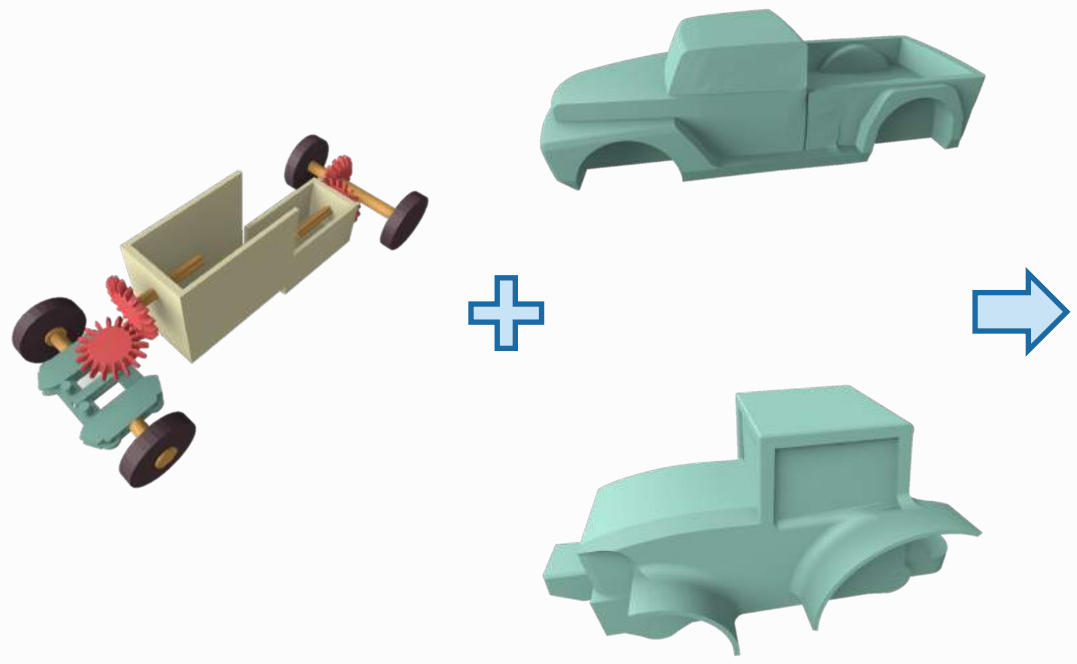

Results

Tapping

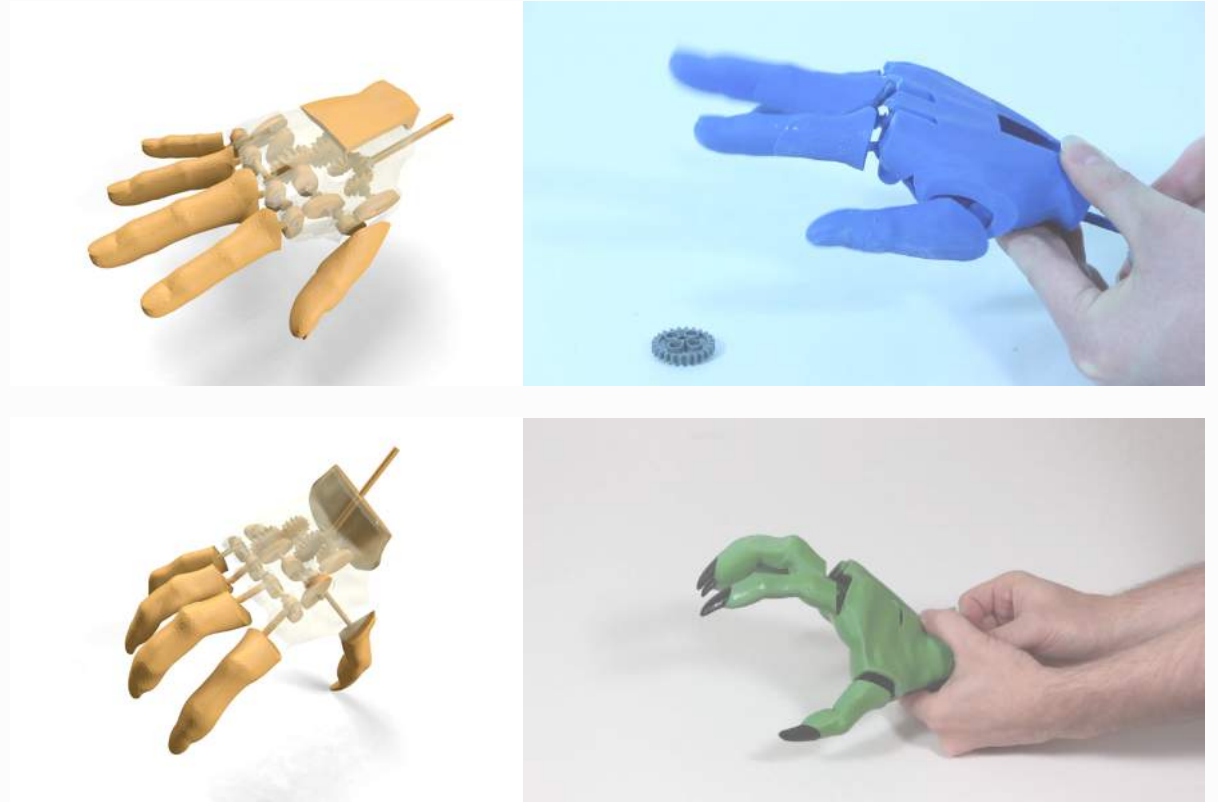
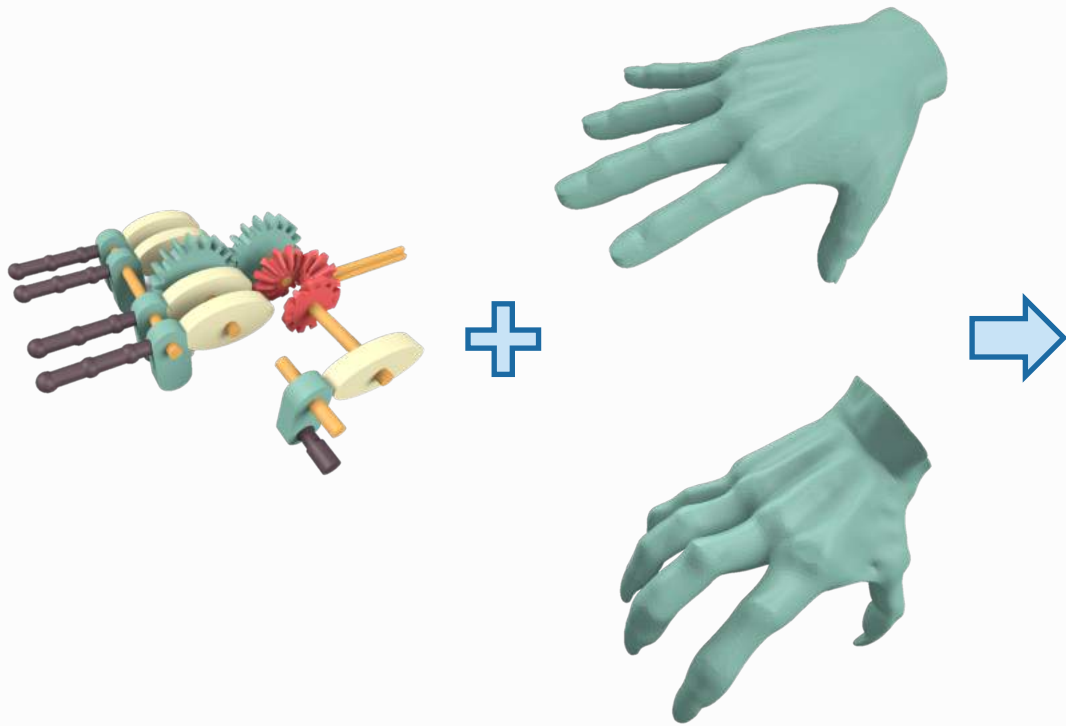

Results

Wind-up

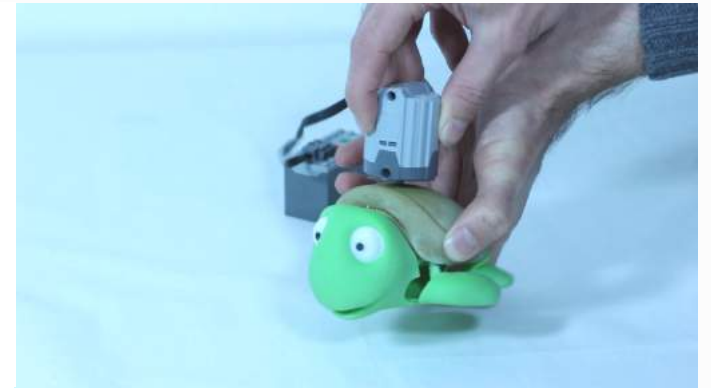
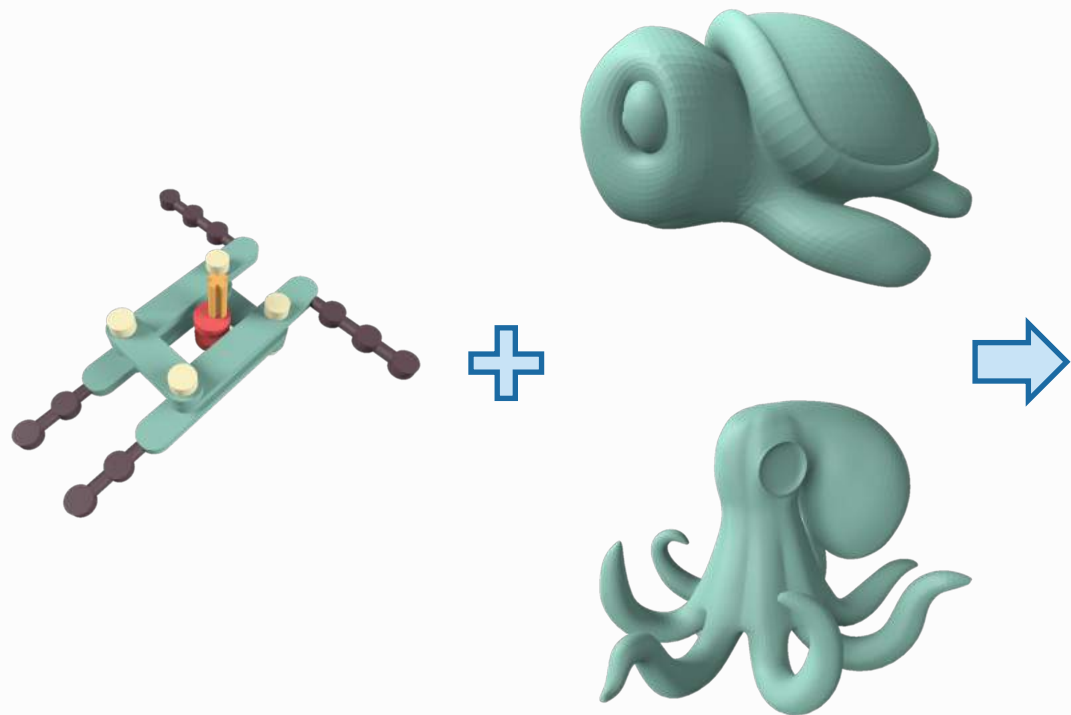

Results

User study and evaluation

- 3 artists, 6 on-site created target shapes, 12 retargeting tasks

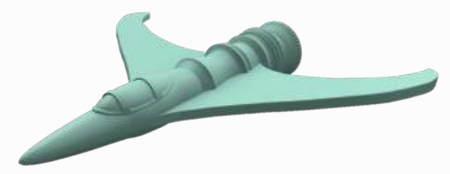
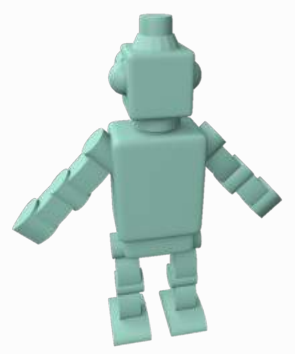
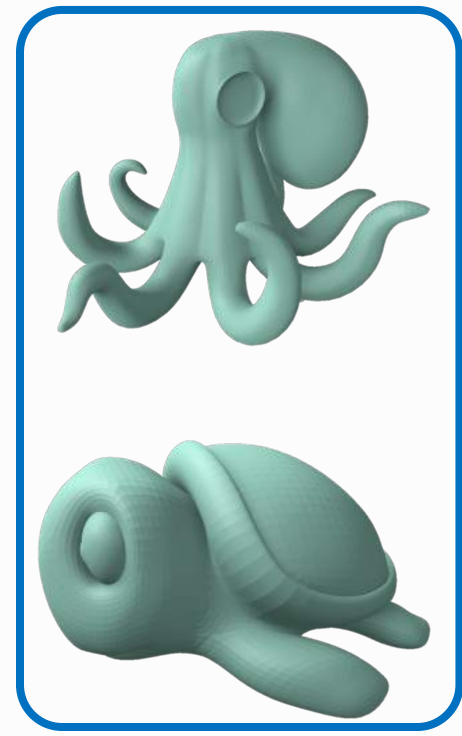
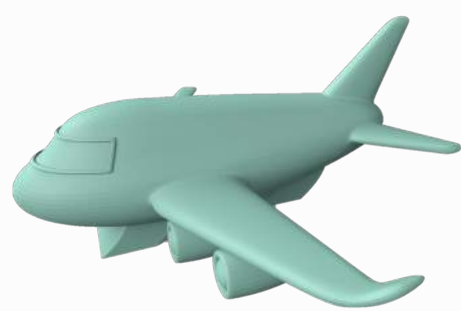

Results

User study and evaluation

- 3 artists, 6 on-site created target shapes, 12 retargeting tasks
- 4 templates, 16 different target shapes in total

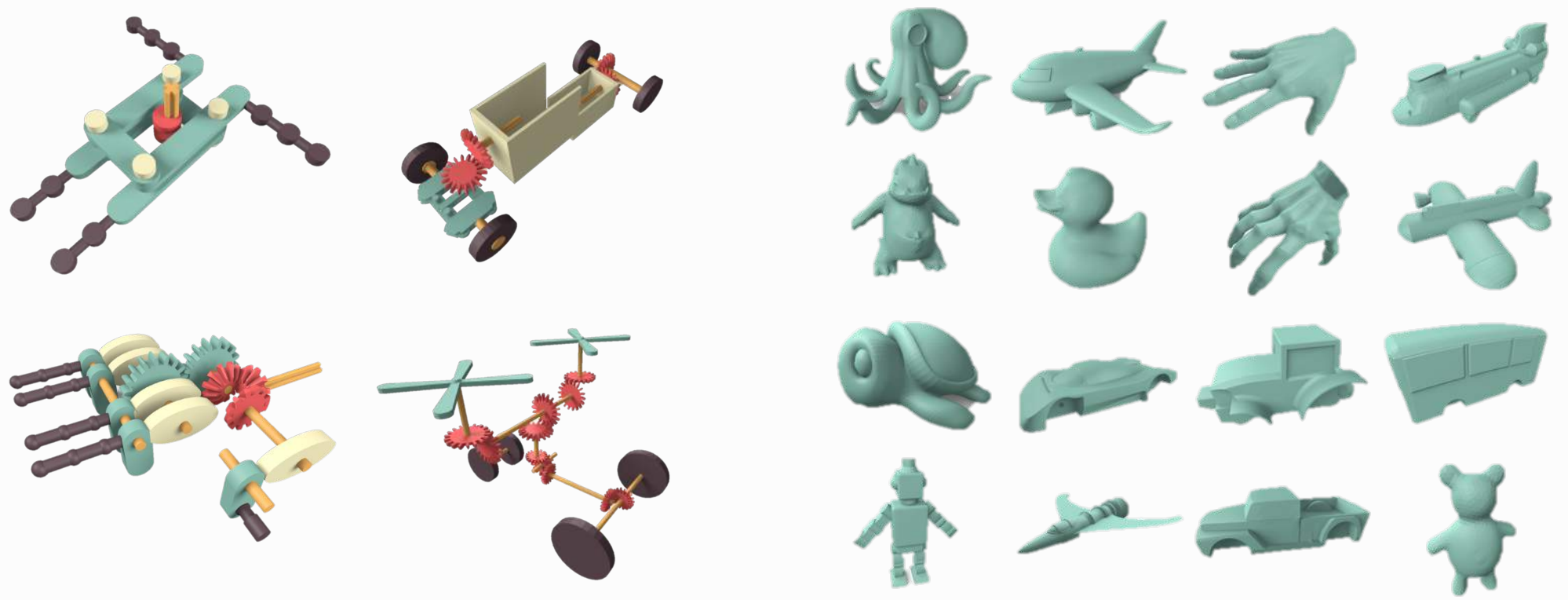

Results

User study and evaluation

- 3 artists, 6 on-site created target shapes, 12 retargeting tasks
- 4 templates, 16 different target shapes in total
- Up to 48 components, 459 variables, 64 hard constraints



Conclusion

- **Novel workflow based on retargeting**
- **Interactivity through differential manipulation**
- **Fabrication-ready customization**

Future work

- **Non-differentiable constraints**
- **More physics (stability, friction...)**
- **Involving more geometry editing**
- **Optimization with discrete components**

Models ready to go!

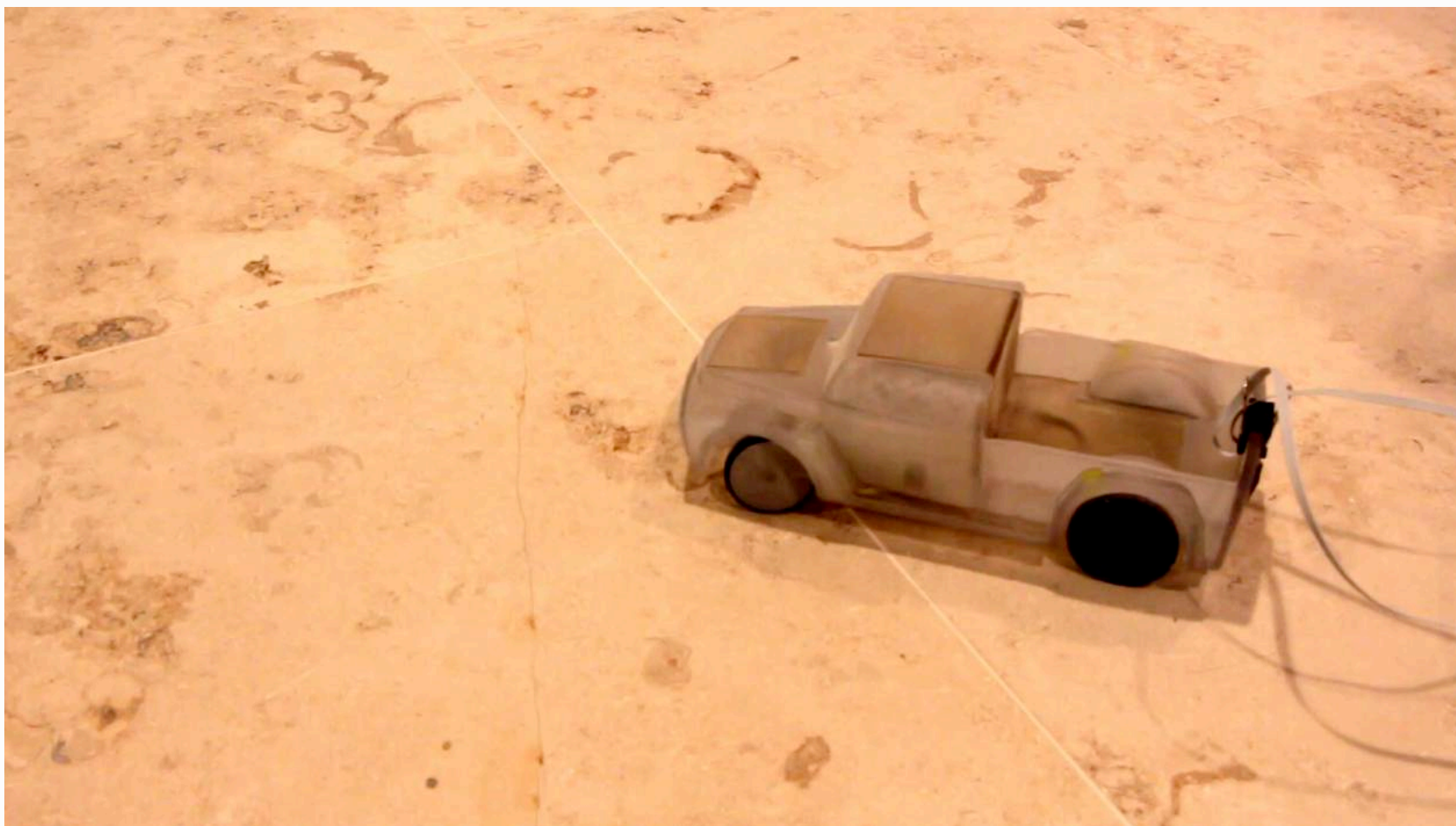

<http://visualcomputing.ist.ac.at/publications/2017/MechRet/>

Visual Computing lab at IST Austria



Bernd Bickel
Assistant Professor

Digital fabrication
Computational design

SIGGRAPH Significant
new researcher award
2017



Chris Wojtan
Professor

Fluid simulation
Physical simulation

SIGGRAPH Significant
new researcher award
2016

<http://visualcomputing.ist.ac.at/openpositions/>



High5!

Thank you for your attention!

- Special thanks to Abbas Saleh, Daniel Bösze, and David Ronnes for participating in our user study and allowing us to use their models created during the user study, and the authors of the remaining models for sharing them on Thingiverse.
- This project has received funding from the European Union's Horizon 2020 research and innovation program under the Marie Skłodowska-Curie grant agreement No 642841 and under the European Research Council (ERC) grant agreement No 715767.



The DiSTRO logo, with the word 'DiSTRO' in a bold, green, sans-serif font.



European Research Council
Established by the European Commission

Backup slides

- Solidworks export xml
- Parsing xml to connection graph

```
<?xml version="1.0" encoding="UTF-8" standalone="no" ?>
<SimMechanicsImportXML version="1.0" xmlns="urn:mathworks:simmechanics:import" xmlns:xsi="http://
www.w3.org/2001/XMLSchema-instance">
<Created by="" on="03/05/15|16:35:33" using="SimMechanics Link Version 4.4" from="SolidWorks 22.4.0"/
>
<ModelUnits mass="kilogram" length="millimeter"/>
<DataUnits mass="kilogram" length="meter"/>
<RootAssembly name="trygears" uid="trygears" version="279">
<AssemblyFile name="trygears.SLDASM" type="SolidWorks Assembly"/>
<InstanceTree>
<Instance name="straight bevel gear_iso-1" uid="straight bevel gear_iso-1" entityUid="straight bevel
gear_iso:*T15 I2 06 02">
<Transform>
<Rotation>-1 0 -1.3414655629040871e-016 0 0.98706318736056509 0.16033173159921363
1.293160212422063e-016 0.16033173159921363 -0.98706318736056509</Rotation>
<Translation>0.014320940249864019 -0.0230000000000000013 0</Translation>
</Transform>
</Instance>
<Instance name="axis-1" uid="axis-1" grounded="true" entityUid="axis:*R2 L60">
<Transform>
<Rotation>1 0 0 0 1 0 0 0 1</Rotation>
<Translation>0.0011313676845386943 -0.023 0</Translation>
</Transform>
</Instance>
<Instance name="axis-2" uid="axis-2" grounded="true" entityUid="axis:*R2 L60">
<Transform>
<Rotation>-3.4914813388431334e-015 -1 0 -1 3.491481338843133e-015 7.0384738289175245e-015
-7.0384738289175245e-015 0 -1</Rotation>
<Translation>0.006000000000000000348 0.01196904942968428 0</Translation>
</Transform>
</Instance>
<Instance name="axis-4" uid="axis-4" grounded="true" entityUid="axis:*R2 L60">
<Transform>
<Rotation>1 0 0 0 1 0 0 0 1</Rotation>
<Translation>0.0011313676845386925 0.046839626267807861 0.00015934194119230215</Translation>
</Transform>
</Instance>
<Instance name="wheel-1" uid="wheel-1" entityUid="wheel:*I2 015">
<Transform>
<Rotation>1 0 0 0 0.80814164233508168 -0.58898818827202082 0 0.58898818827202082 0.80814164233508168</
Rotation>
<Translation>-0.025868632315461309 0.046839626267807861 0.00015934194119230326</Translation>
</Transform>
</Instance>
<Instance name="wheel-2" uid="wheel-2" entityUid="wheel:*I2 015">
<Transform>
<Rotation>1 0 0 0 1 0 0 0 1</Rotation>
<Translation>0.020131367684538687 0.046839626267807861 0.00015934194119230152</Translation>
</Transform>
</Instance>
<Instance name="wheel-3" uid="wheel-3" entityUid="wheel:*I2 015">
```

Results

User study and evaluation

- 3 artists, 6 on-site created target shapes, 12 retargeting tasks

