



# Stitch Meshes for Knitting Design

Kui Wu

MIT

# Knitting has a long history



Sock in Ancient Egypt  
200 - 400 CE  
From: the British Museum



Madonna Knitting  
by Bertram of Minden  
1400 - 1410

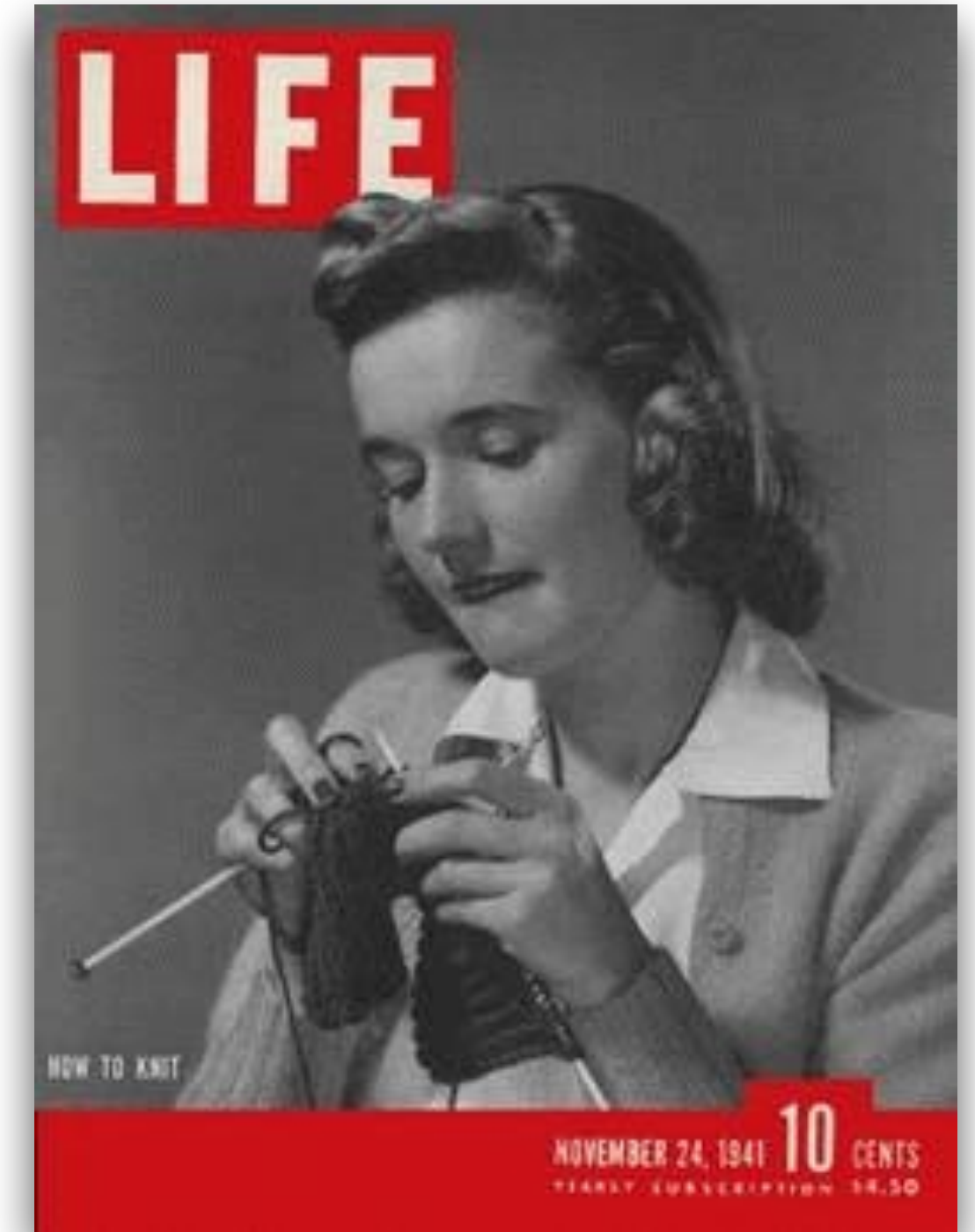

Life magazine's cover story  
November 24, 1941

# Knitting is everywhere



Paris Fashion Week, Fall/Winter 2016/17

# Why knitting?



Stretchable

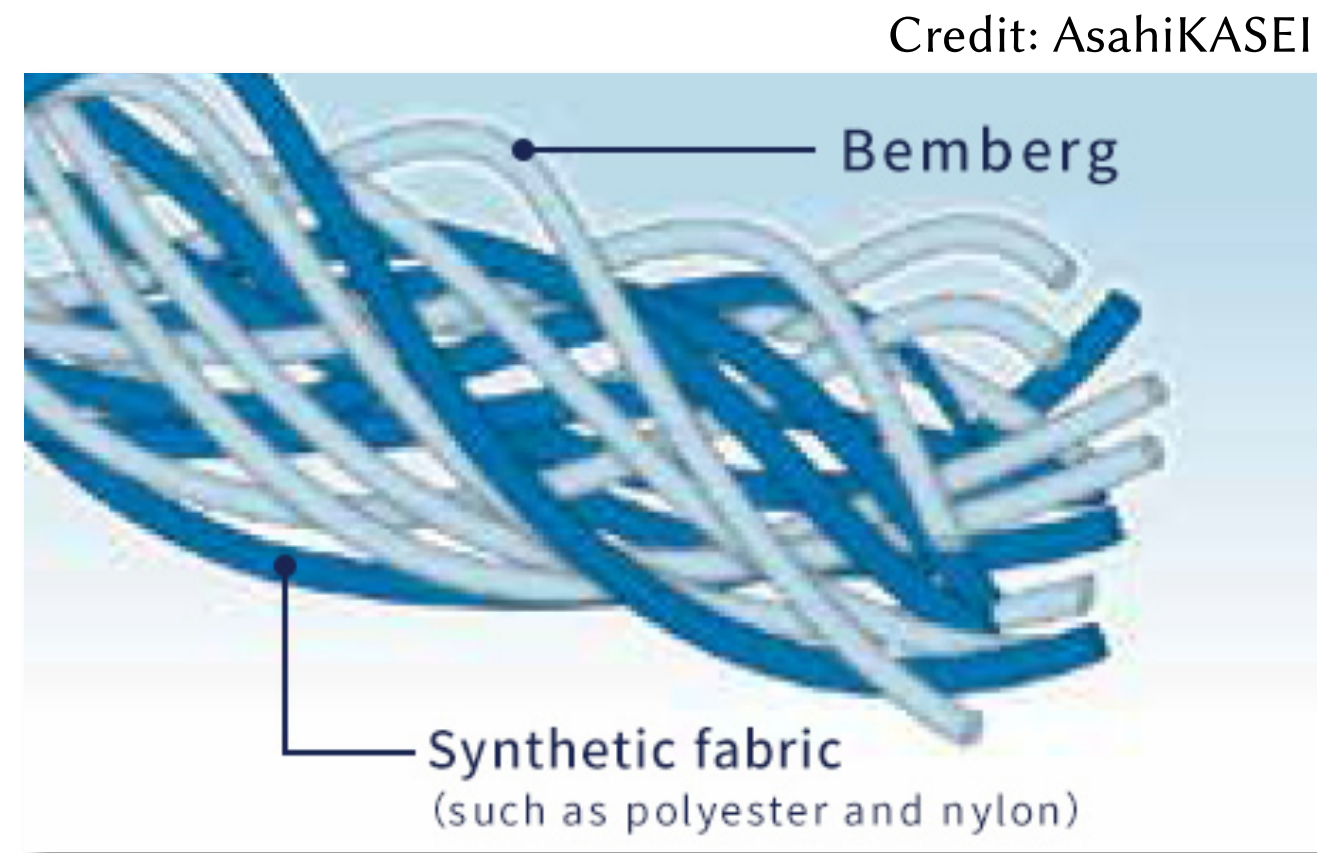

Composite material



Structural continuity



Pattern -> microstructure

# Geometric Structure



# Geometric Structure

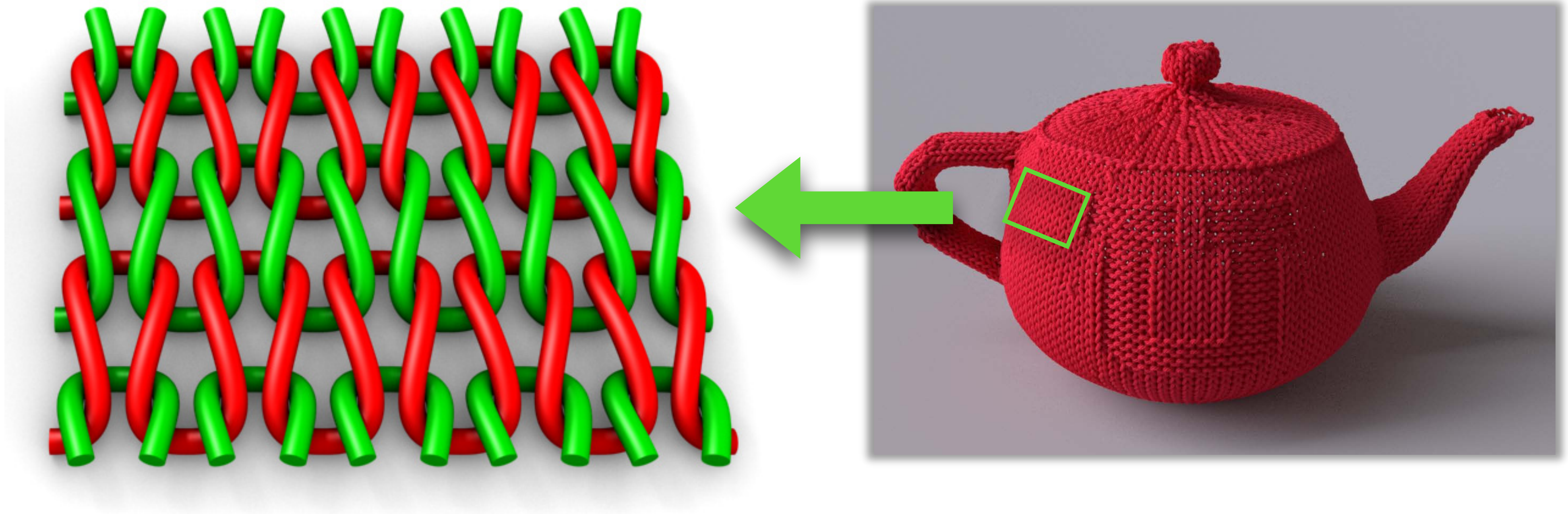

# Geometric Structure

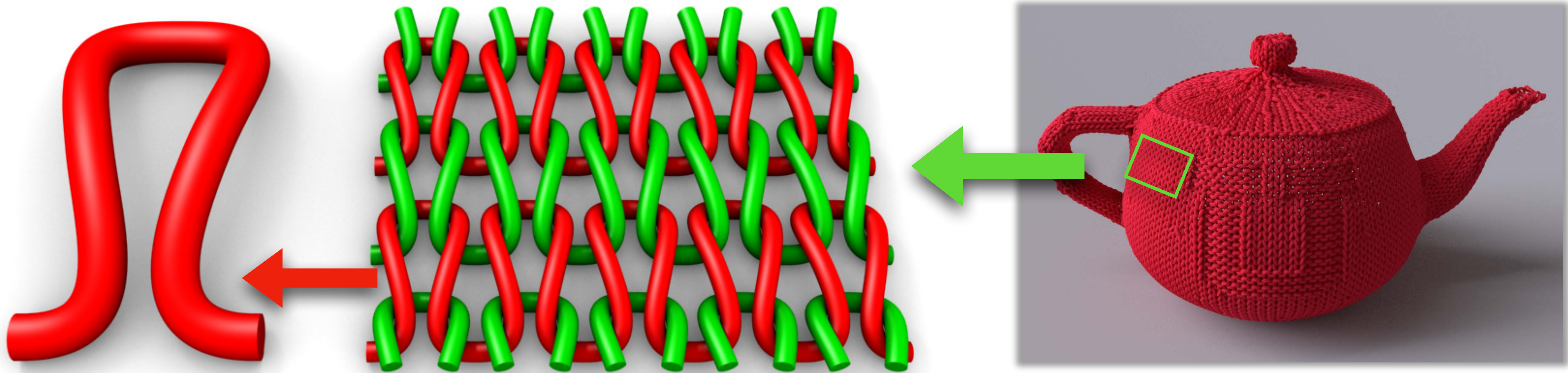

# Various Knitting Patterns & Shapes



[Underwood '09]



[Leaf et al. '18]





# Knittable Stitch Meshes

Kui Wu Hannah Swan Cem Yuksel

*University of Utah*



# Stitch Meshes [Yuksel et al. '12]



!!! Not knittable !!!

# Knittable Stitch Mesh

Stitch meshes

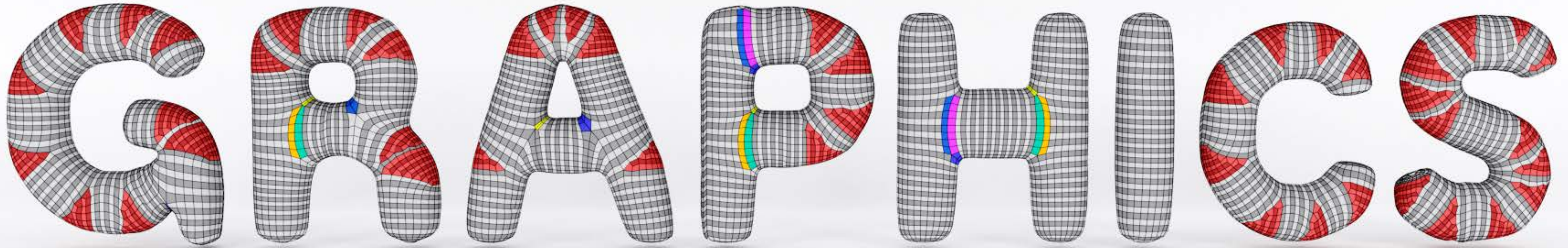

Knitted results



# Stitch Meshes [Yuksel et al. '12]



Yarn Loop

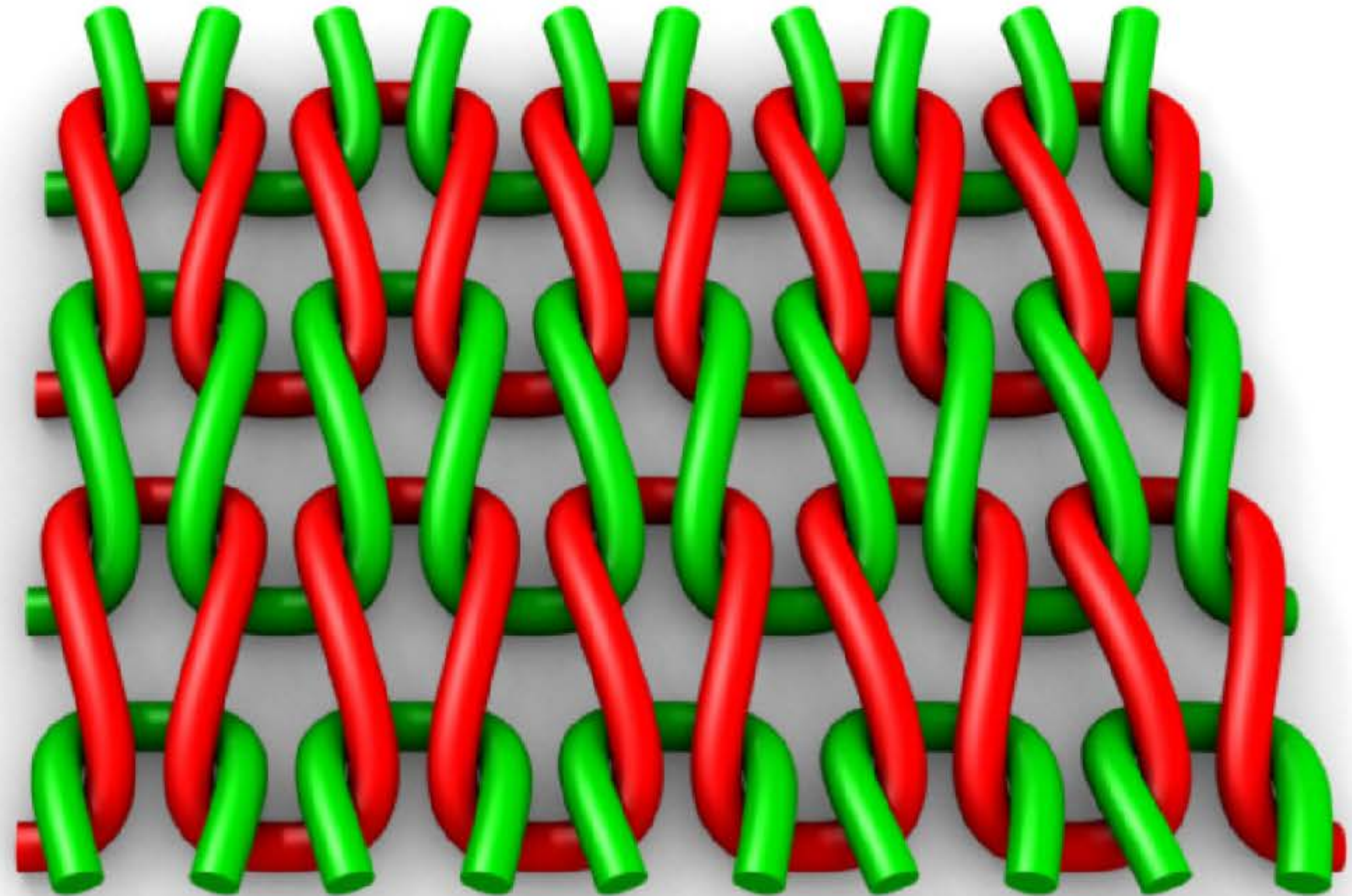

# Stitch Meshes [Yuksel et al. '12]

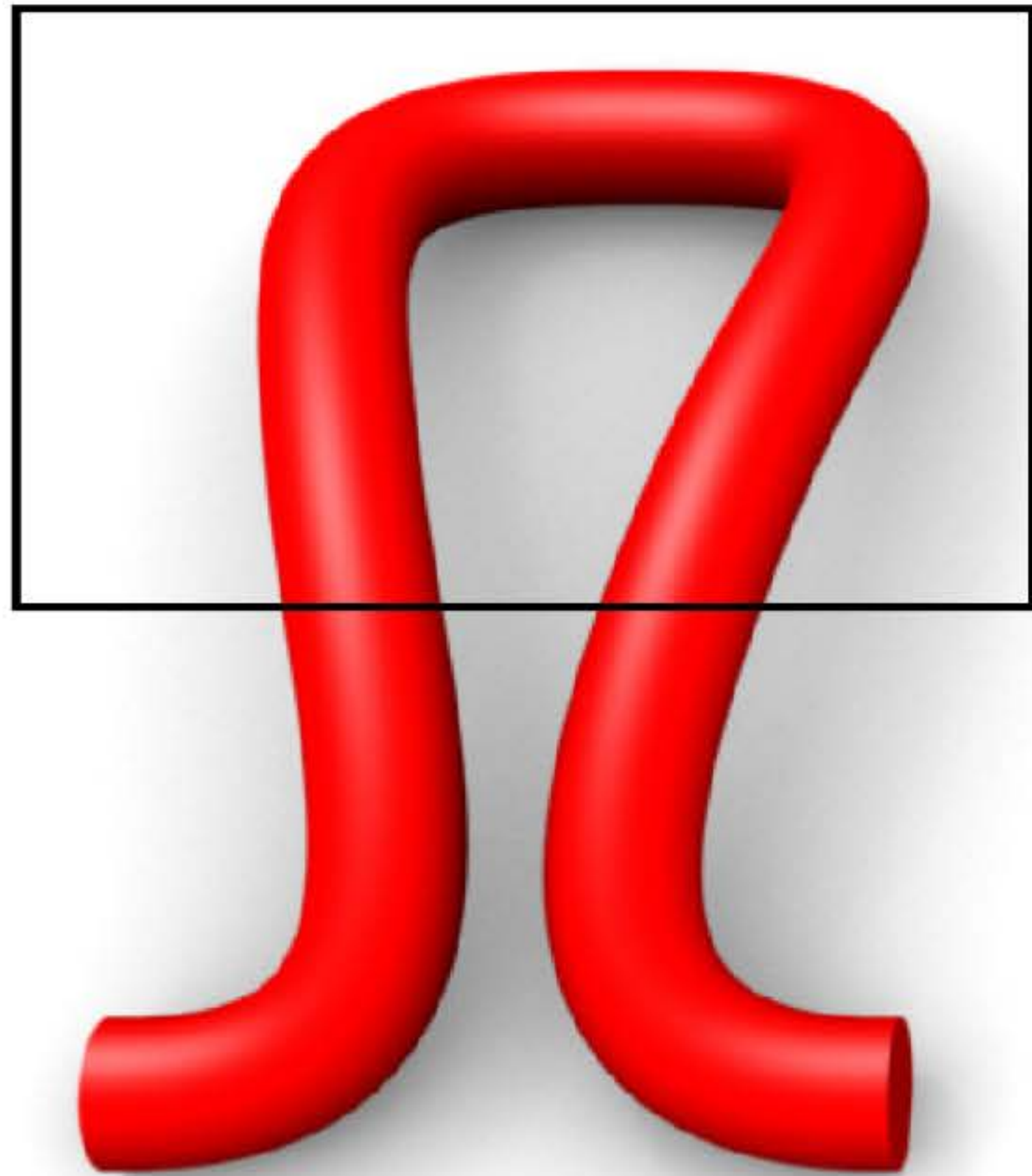

Yarn Loop

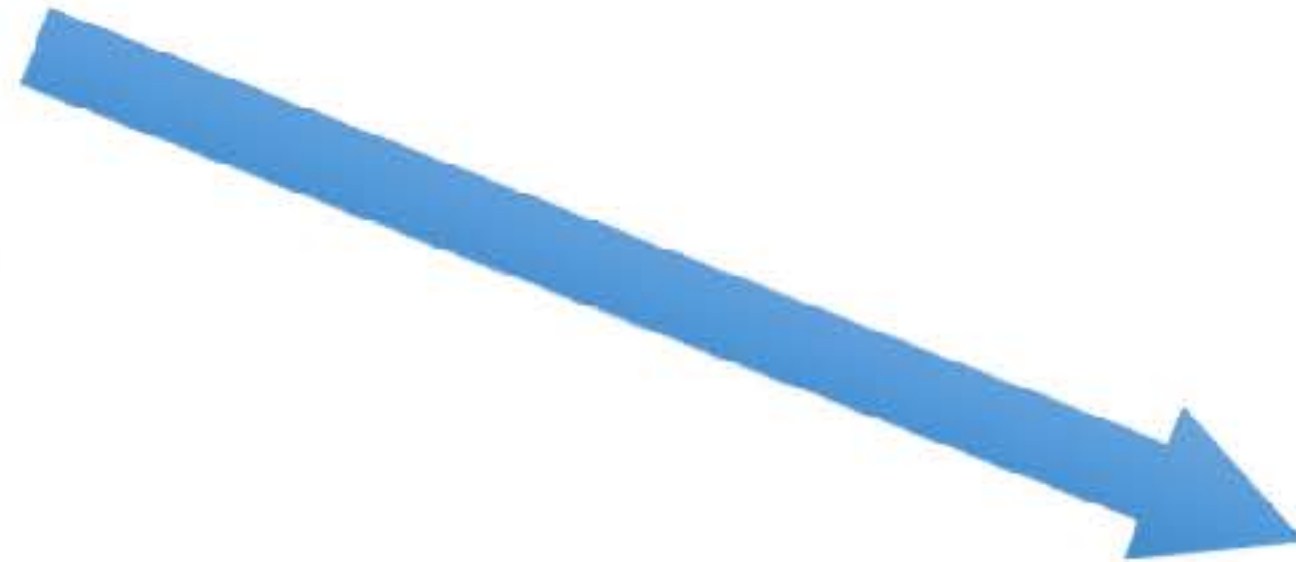

# Stitch Meshes [Yuksel et al. '12]

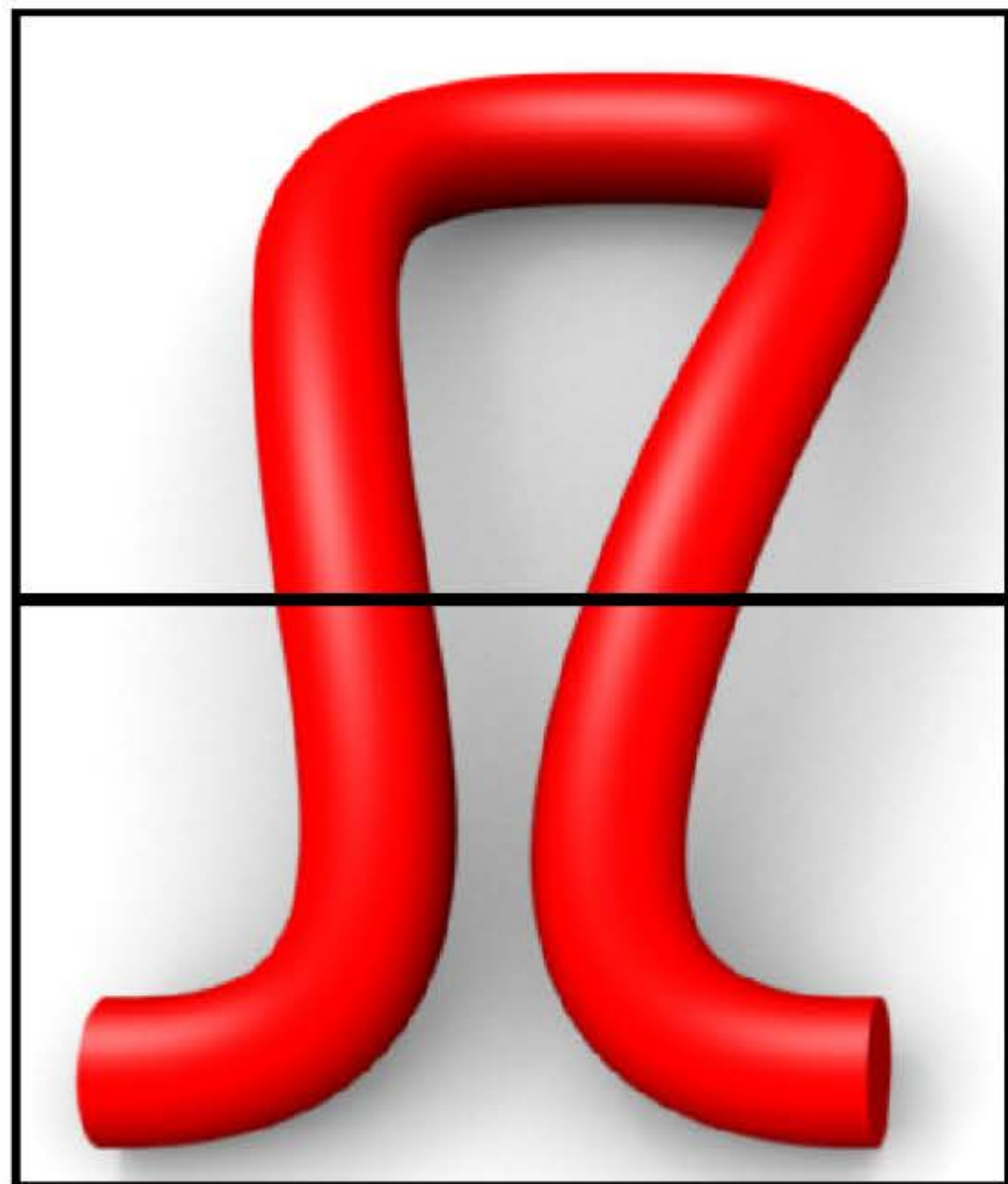

Yarn Loop

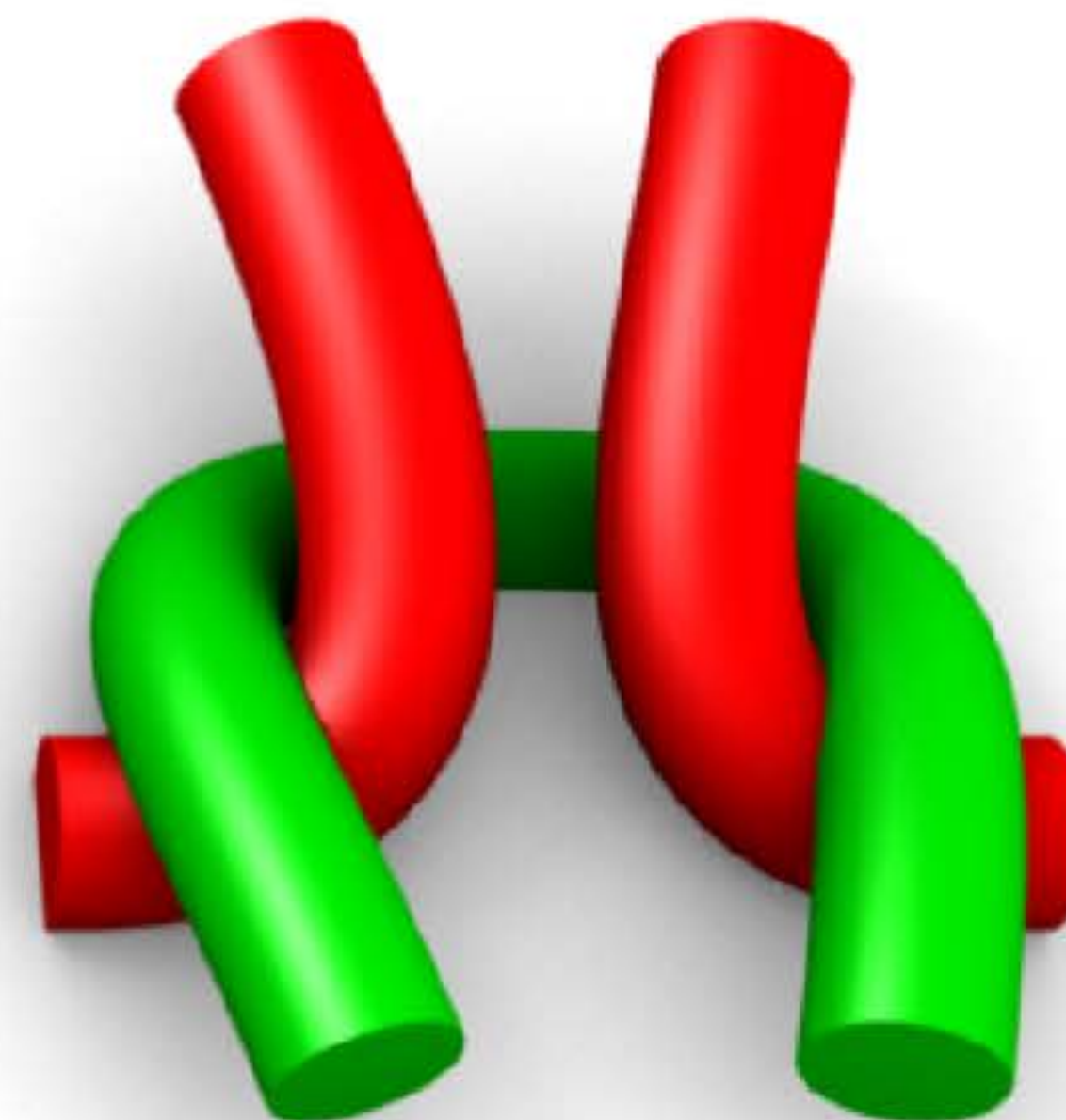
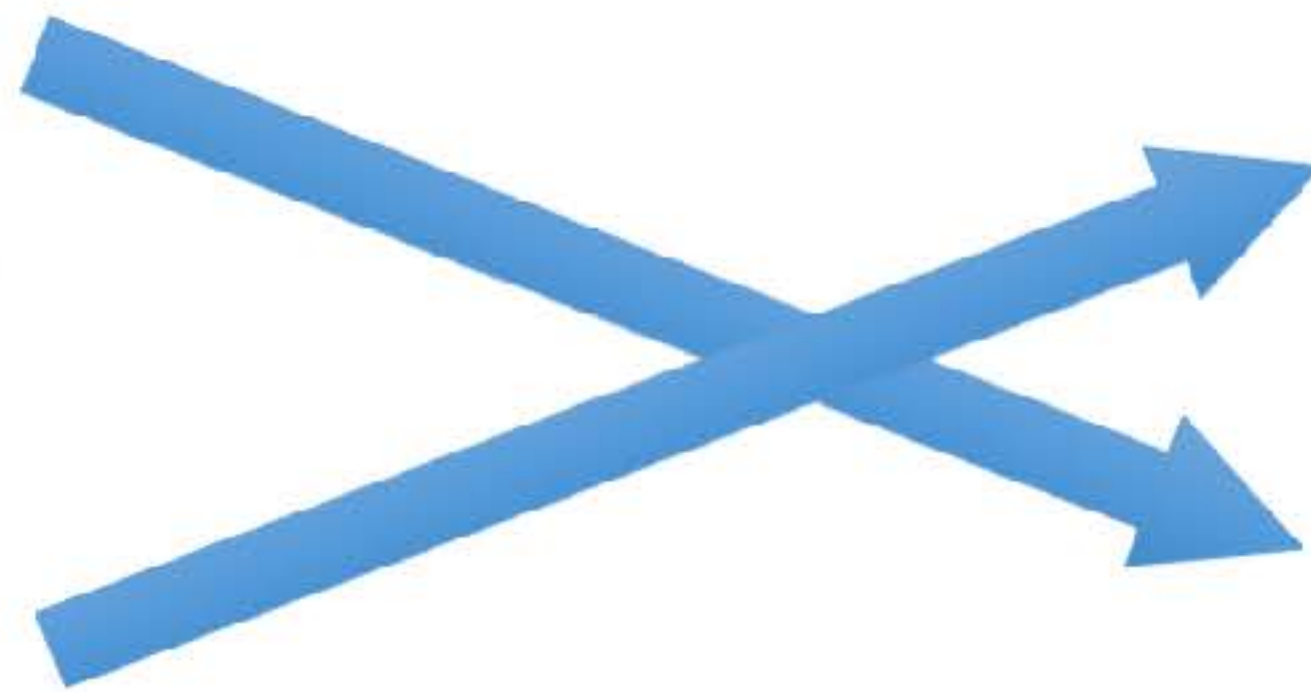

# Stitch Meshes [Yuksel et al. '12]

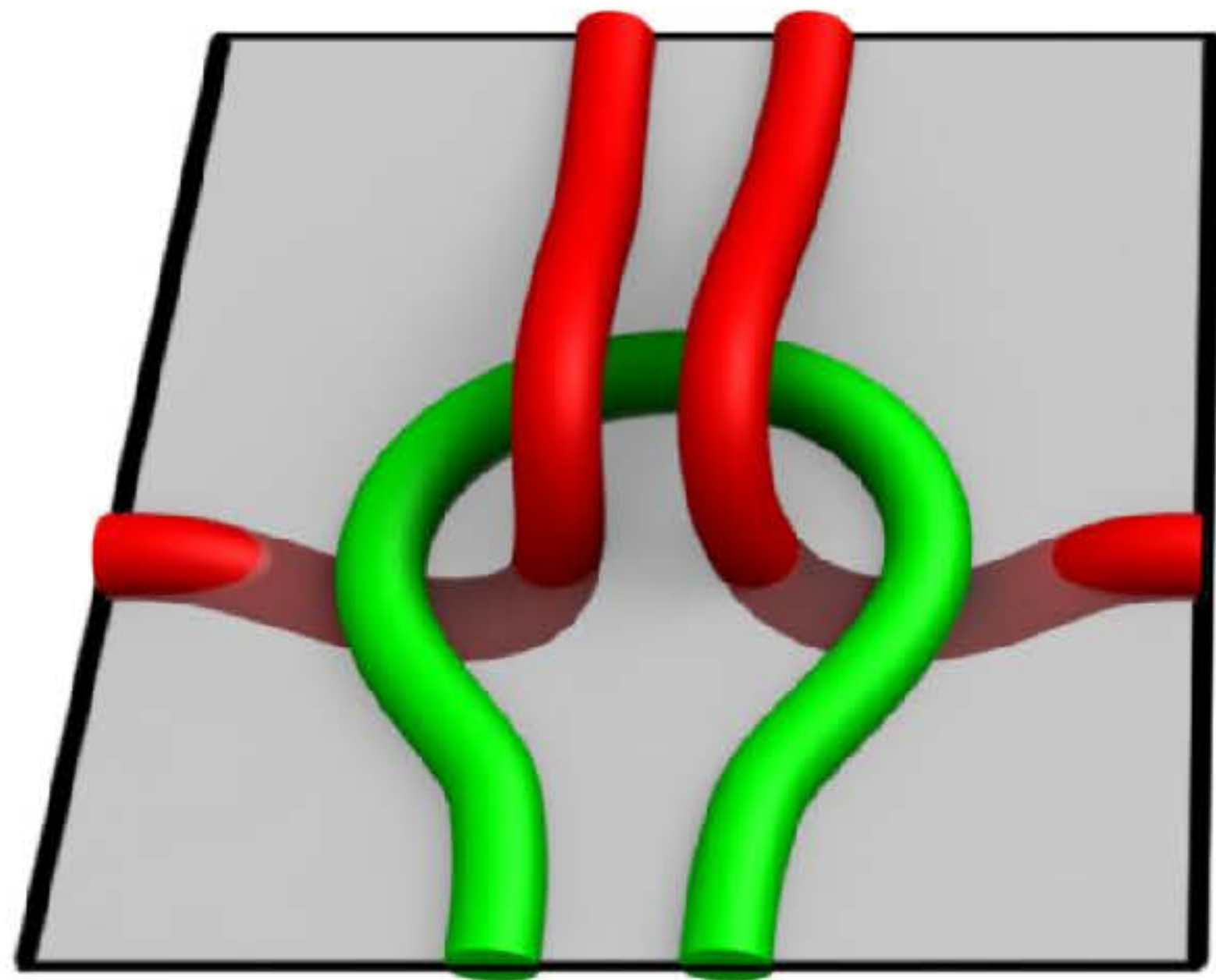

Stitch mesh face

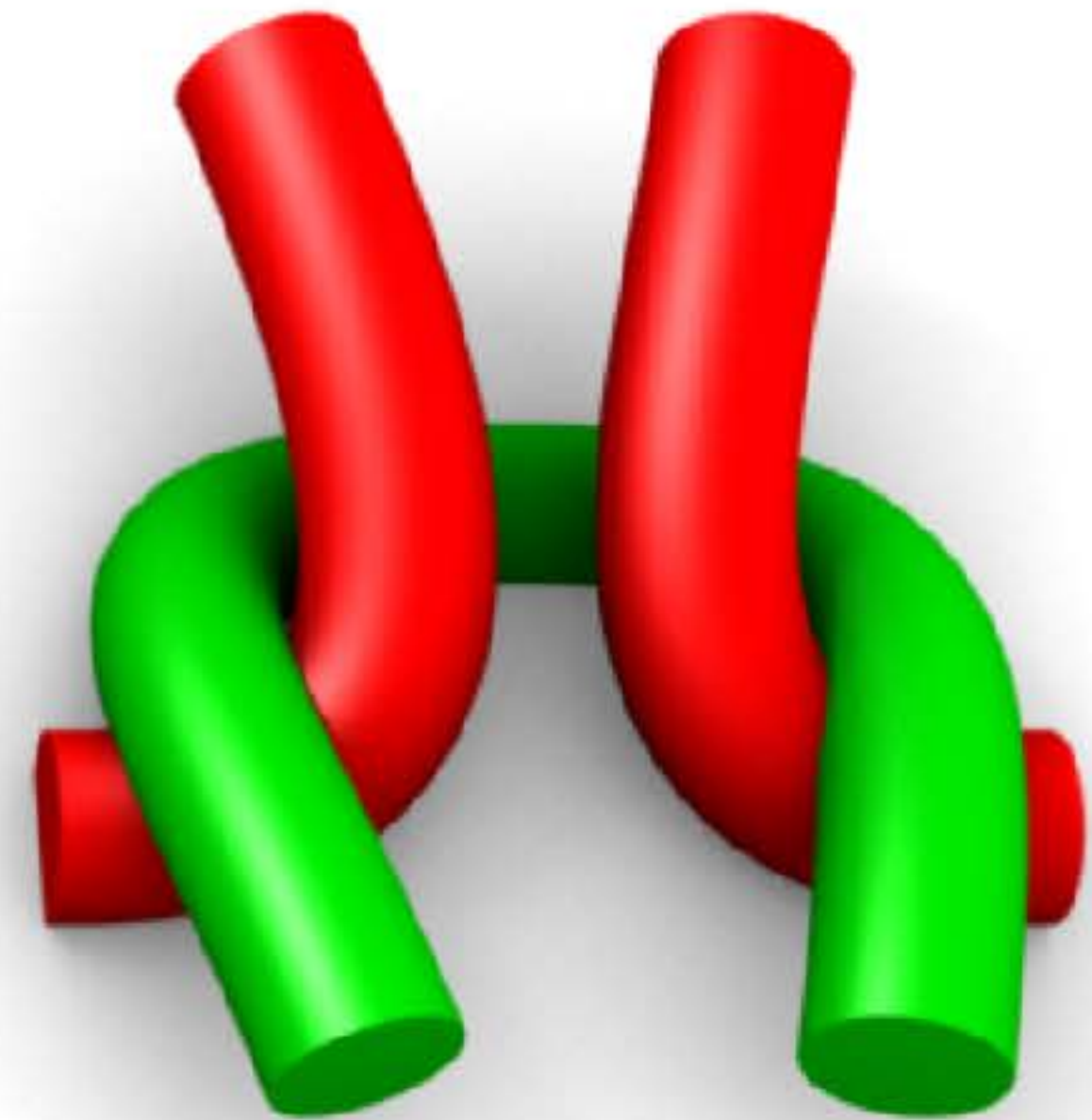

Stitch

# Stitch Meshes [Yuksel et al. '12]

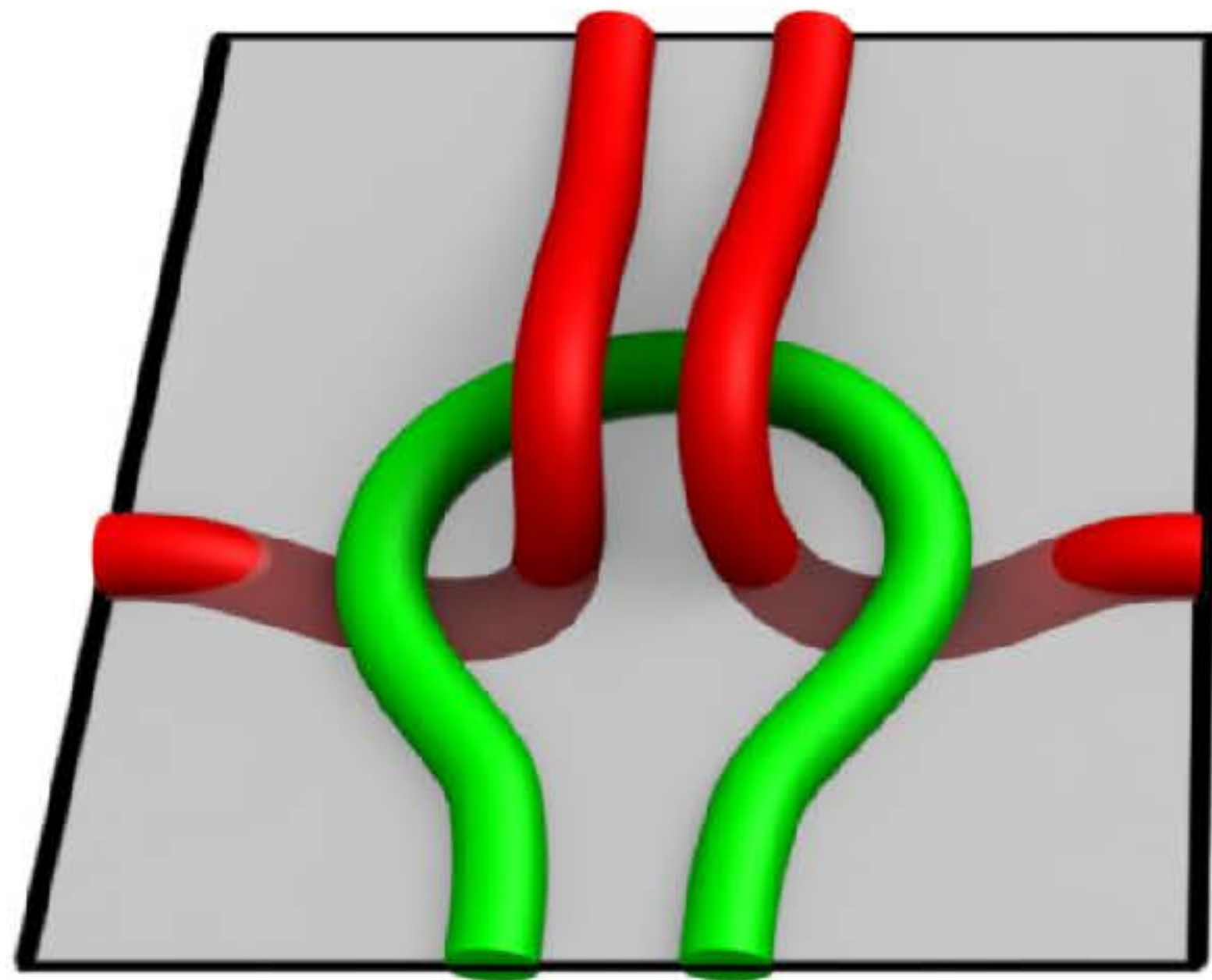

Stitch mesh face



Edge labels



# Stitch Meshes [Yuksel et al. '12]

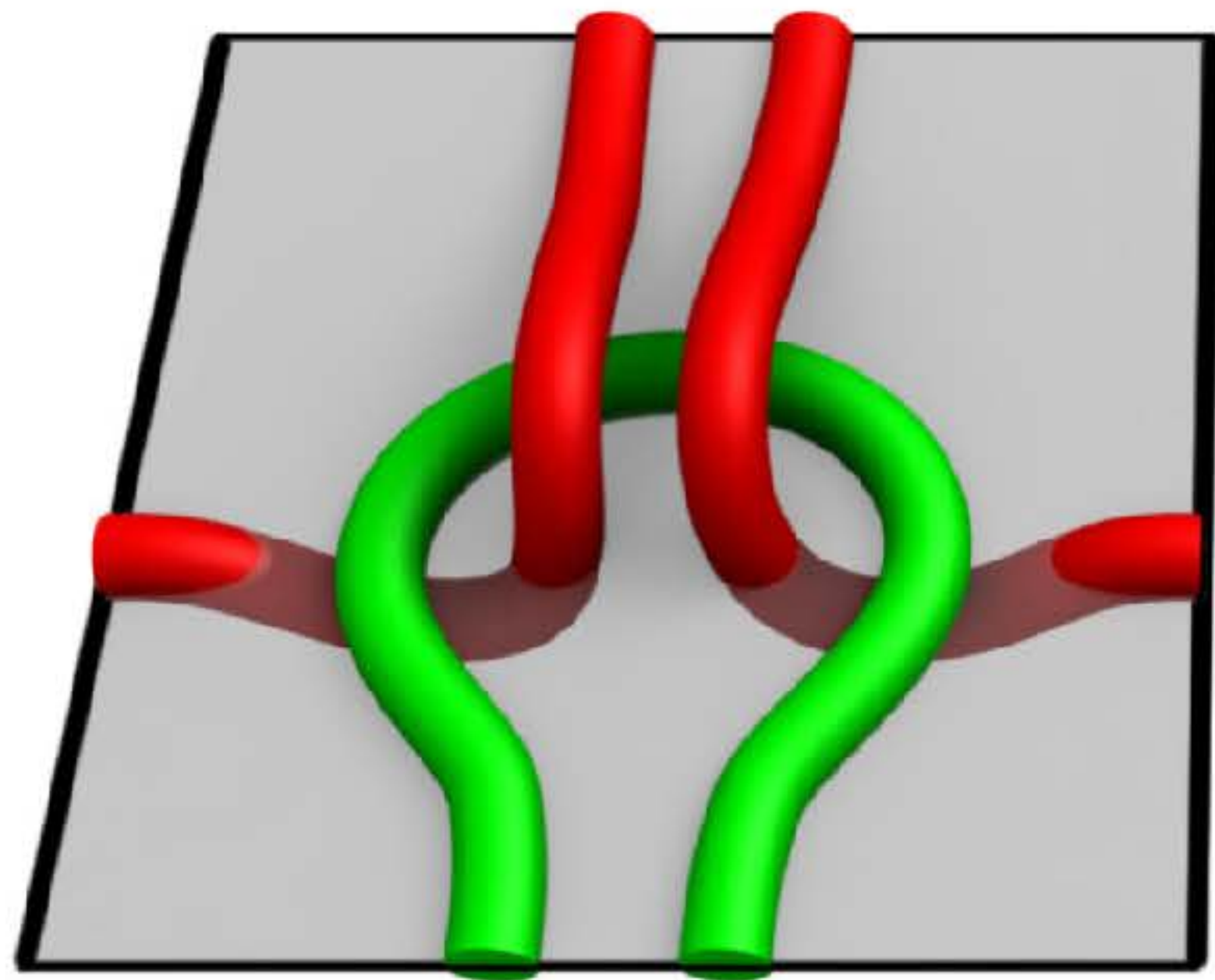

Stitch mesh face

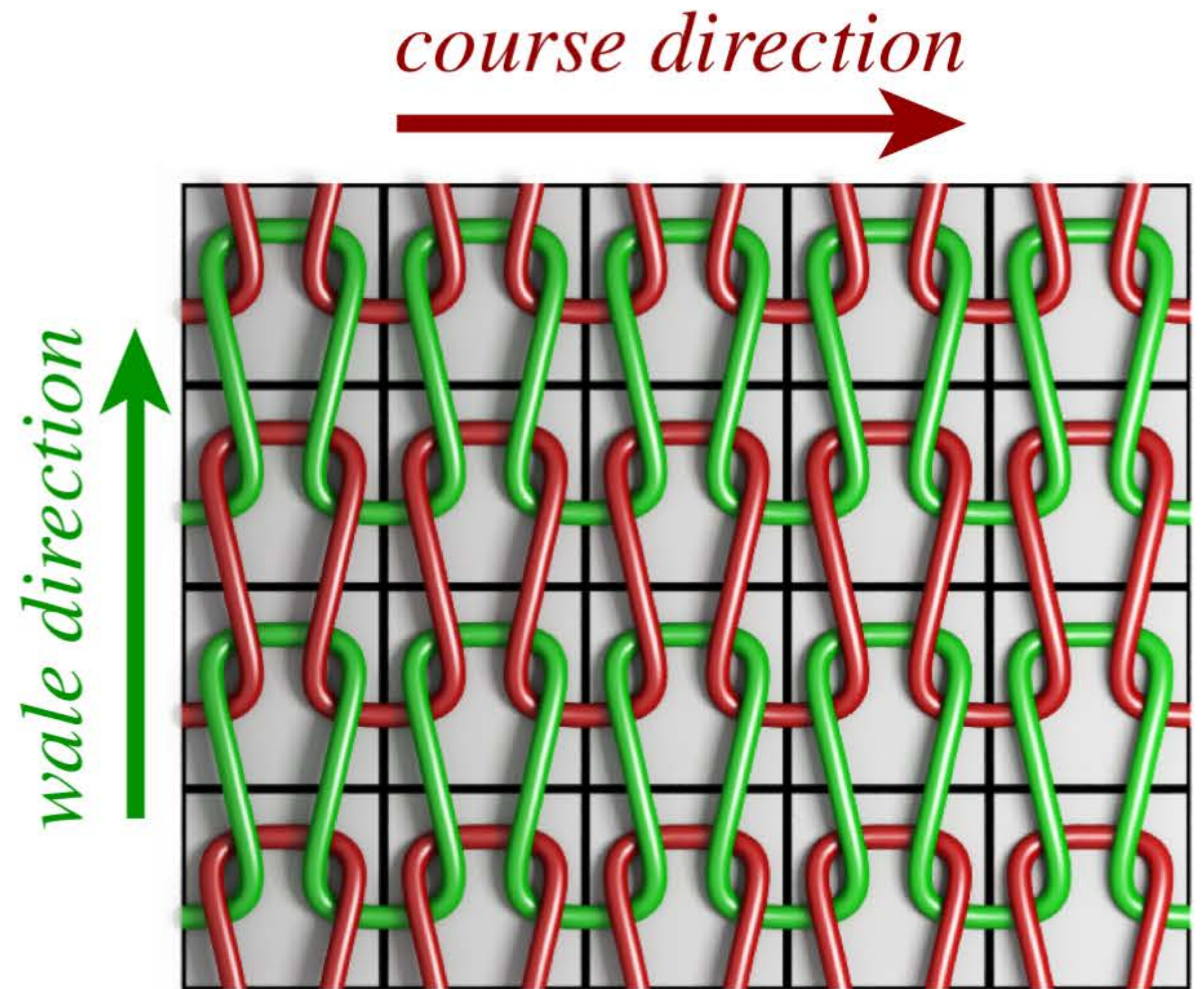

Patch

# Stitch Meshes [Yuksel et al. '12]

Stitch meshes provide a practical way of modeling knitted structure

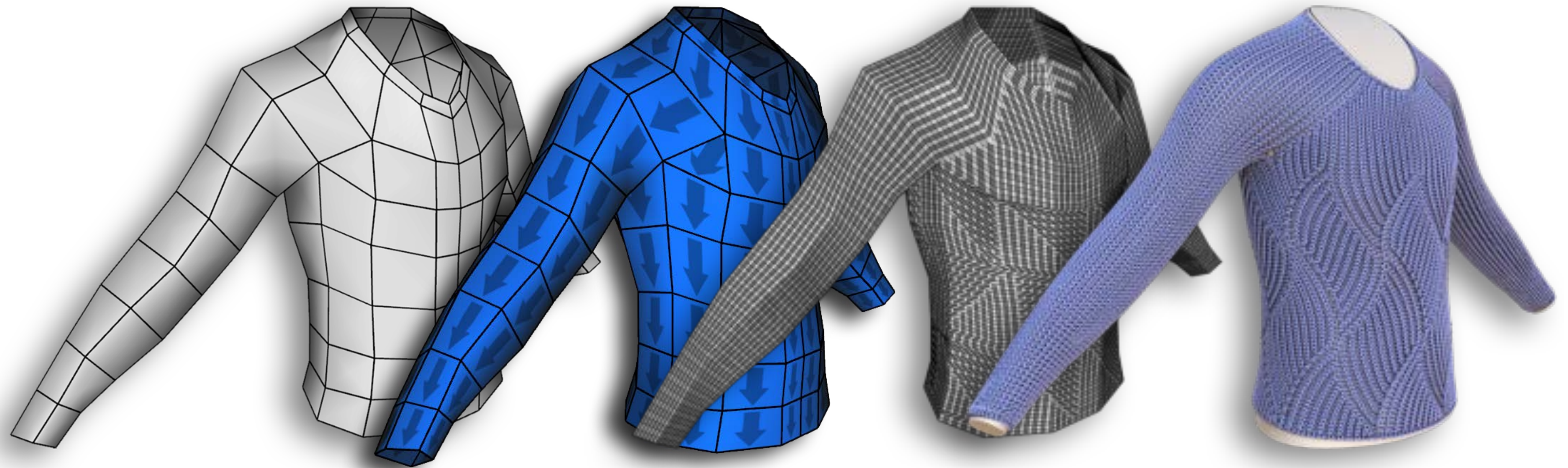

Input mesh

Labelled mesh

Stitch mesh

Yarn-level model

# Stitch Meshes [Yuksel et al. '12]

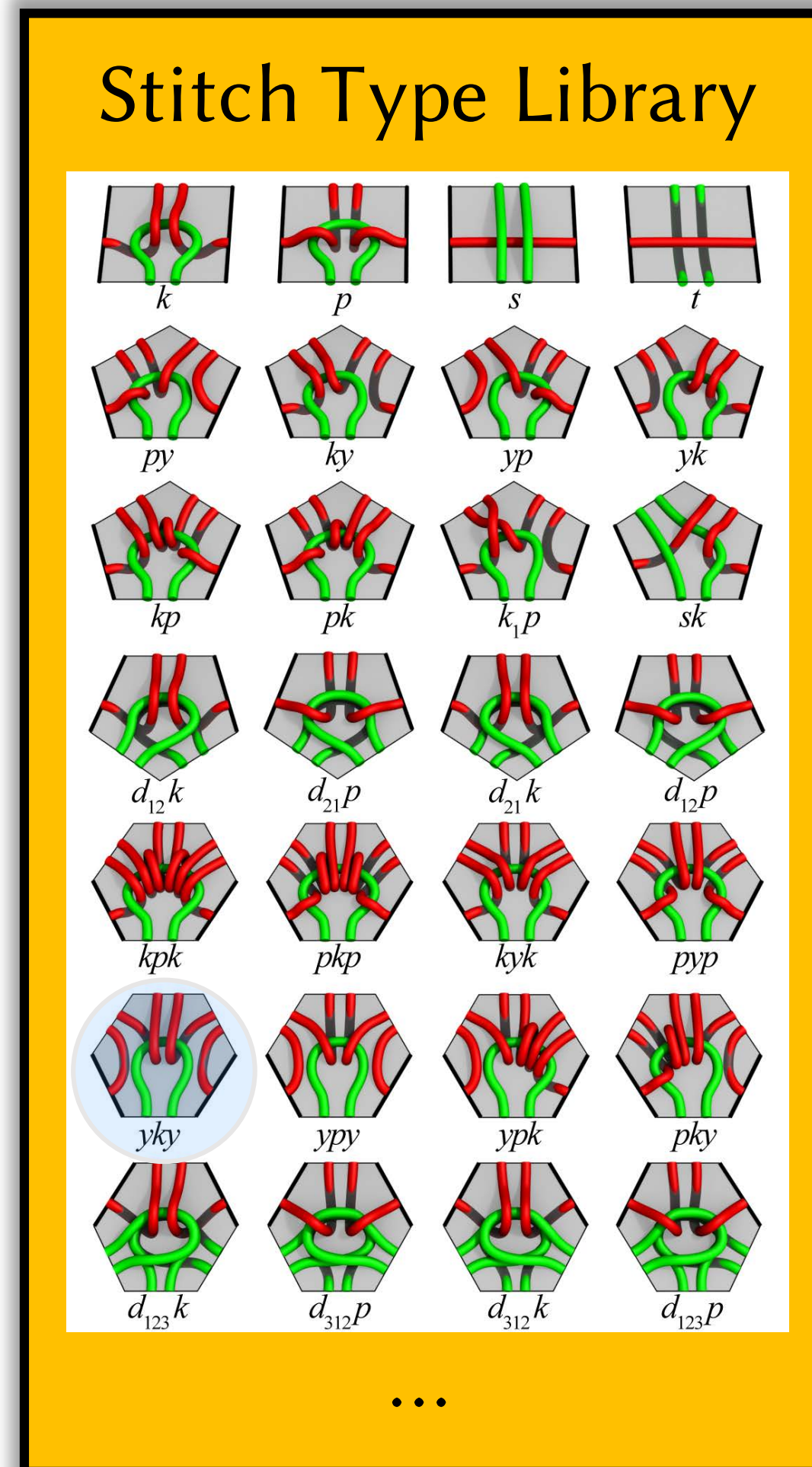

# Stitch Meshes [Yuksel et al. '12]

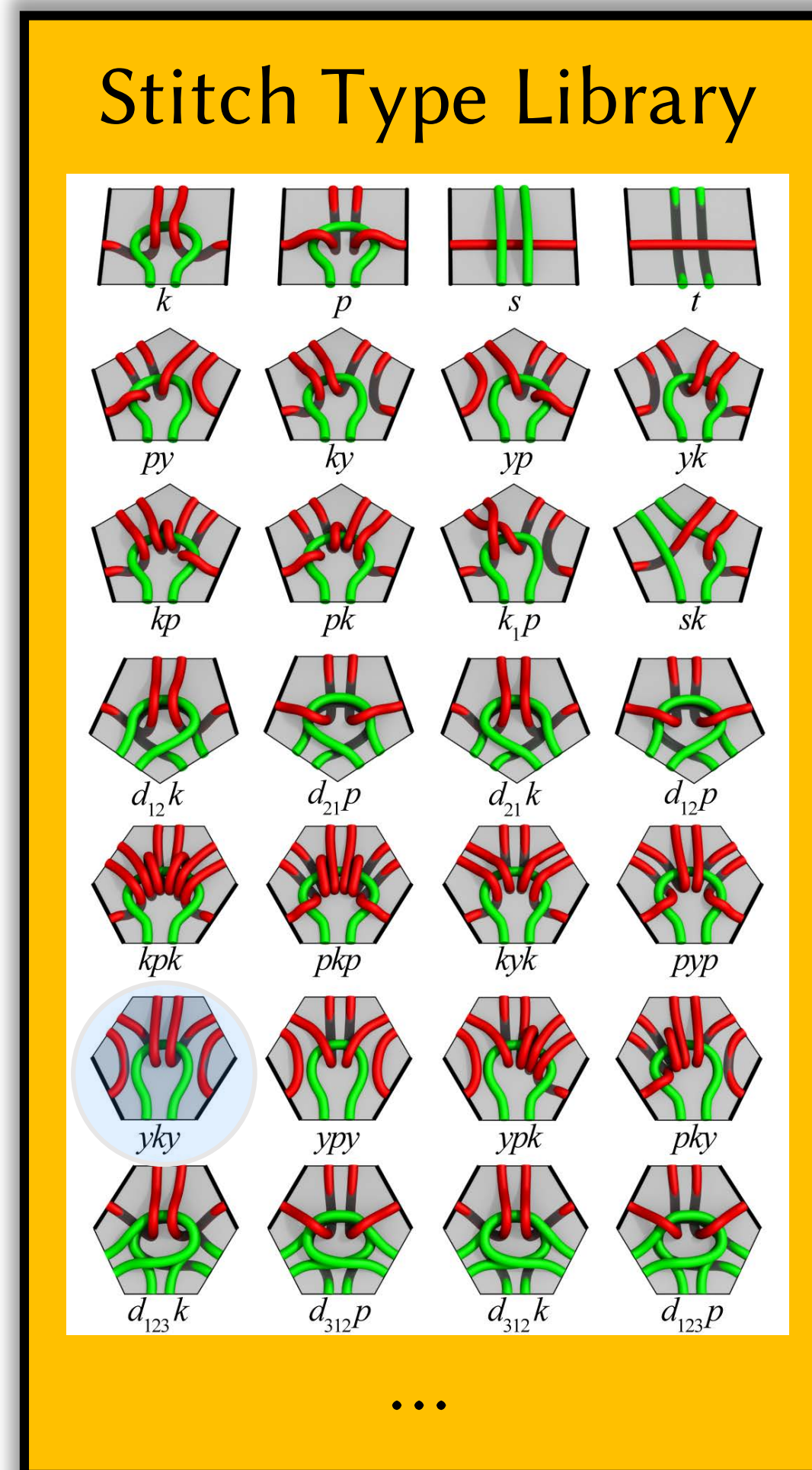

Openwork Trellis Pattern

# Stitch Meshes [Yuksel et al. '12]

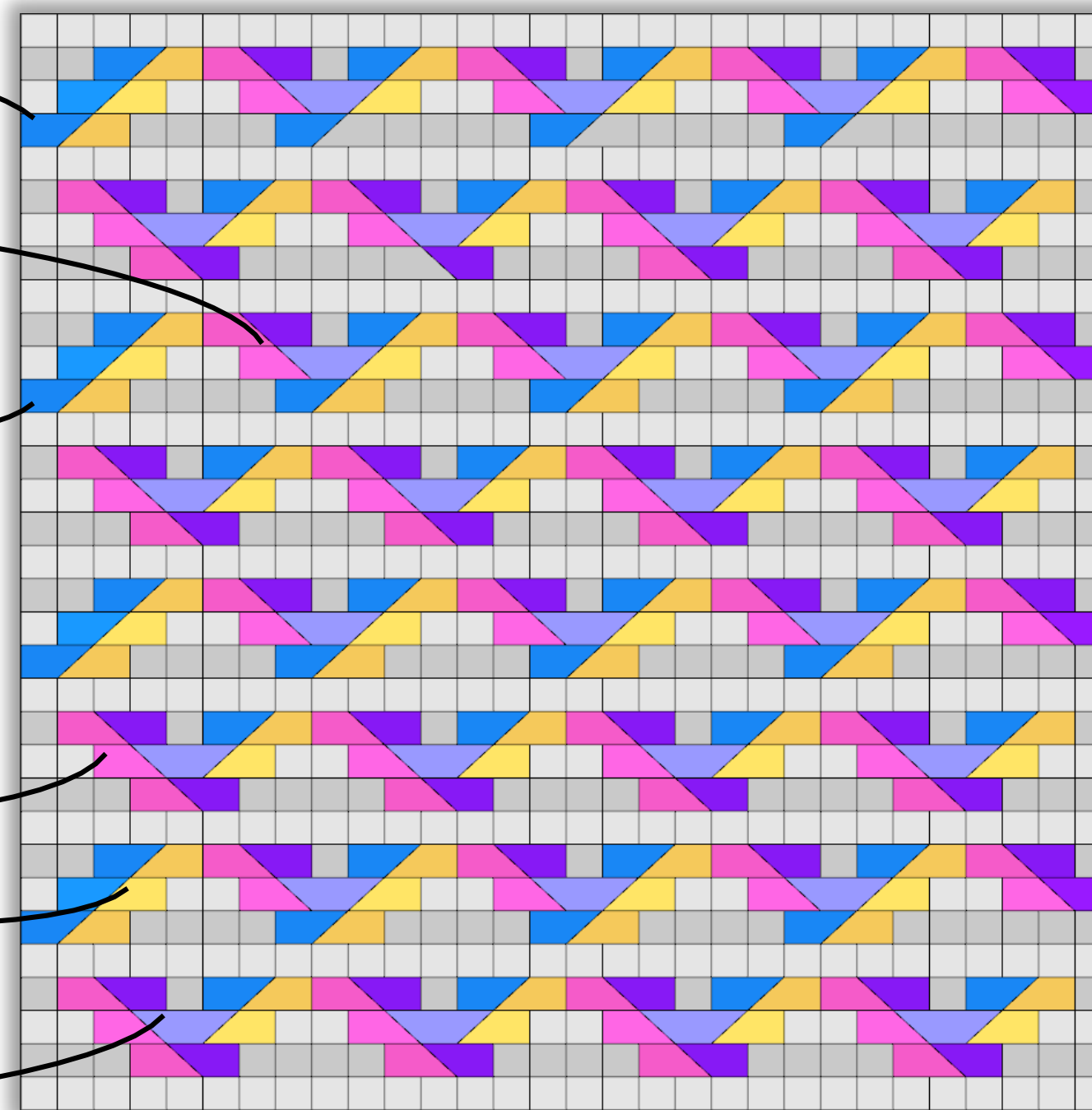
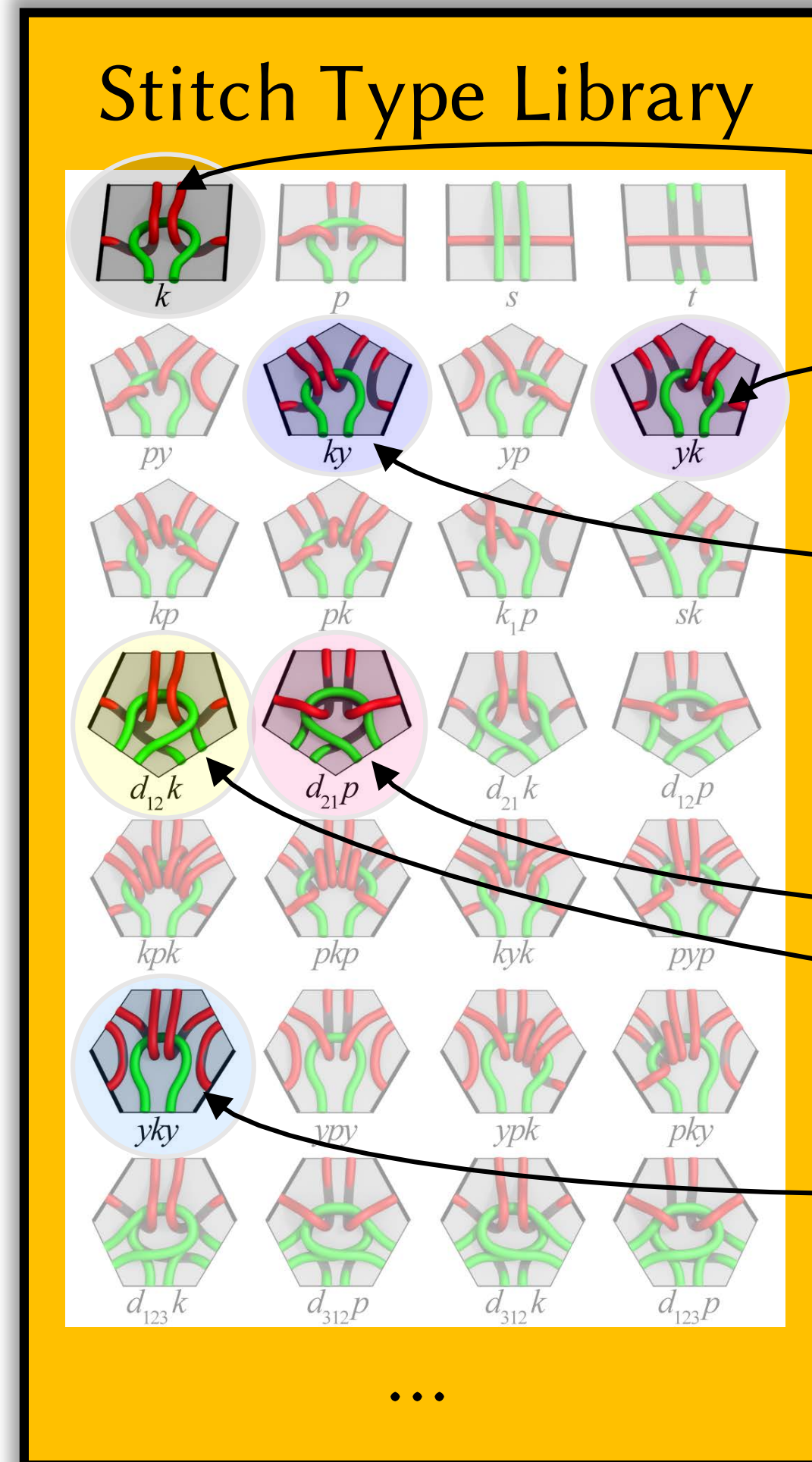

Openwork Trellis Pattern

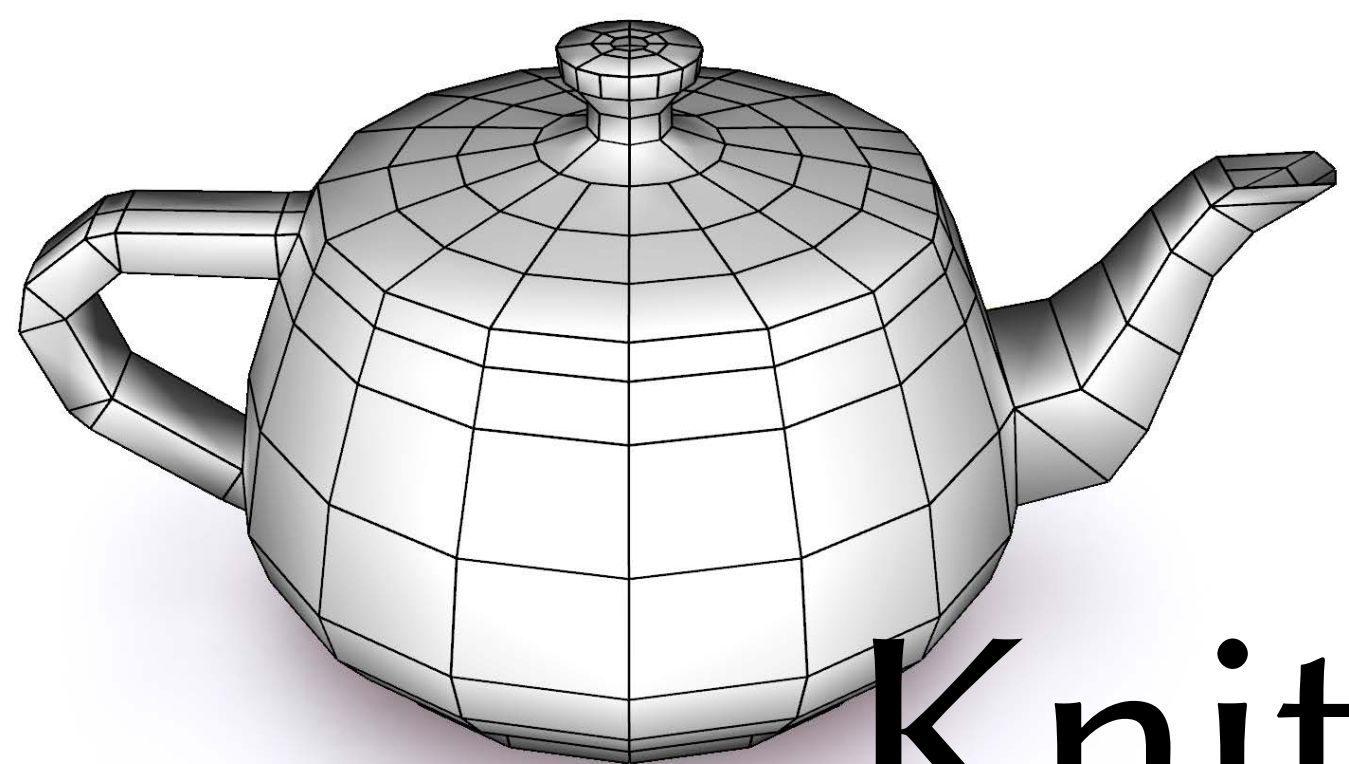

Input mesh



Knitted model

# Knittable Stitch Mesh

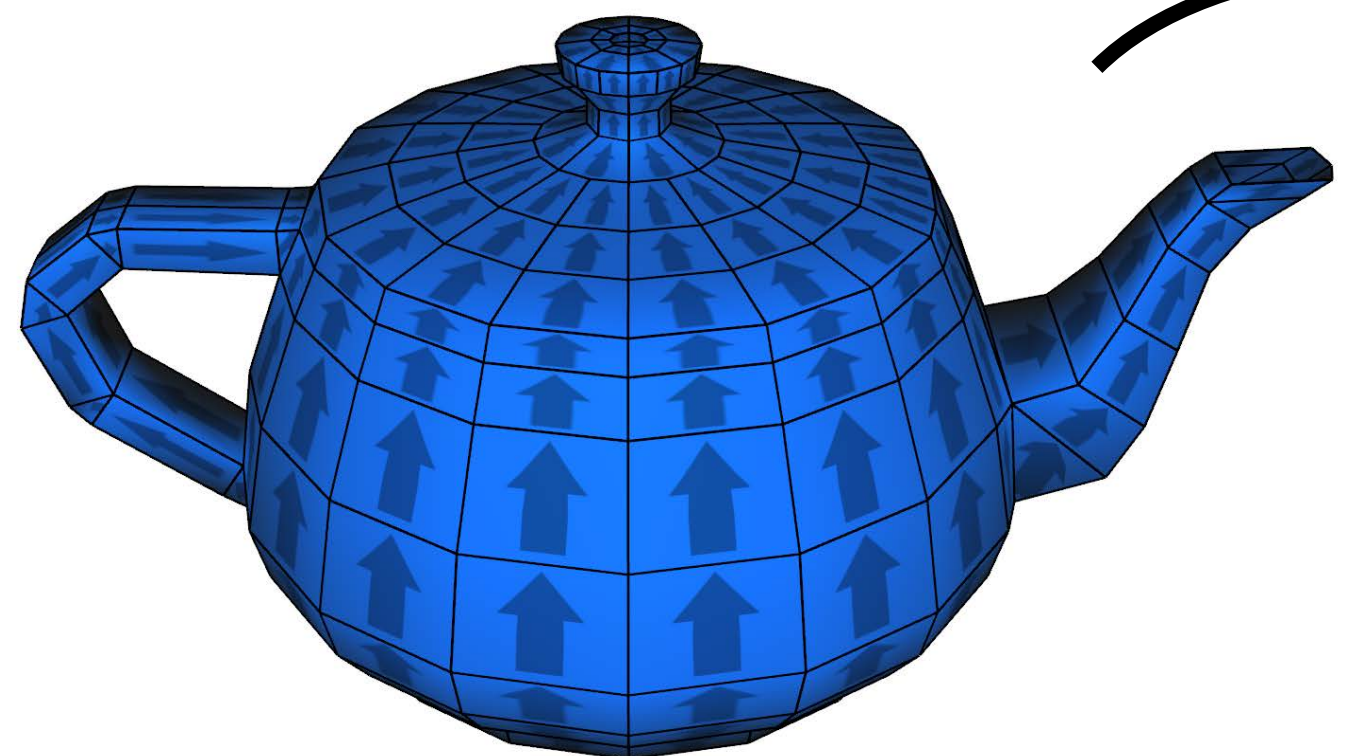

Labelled mesh

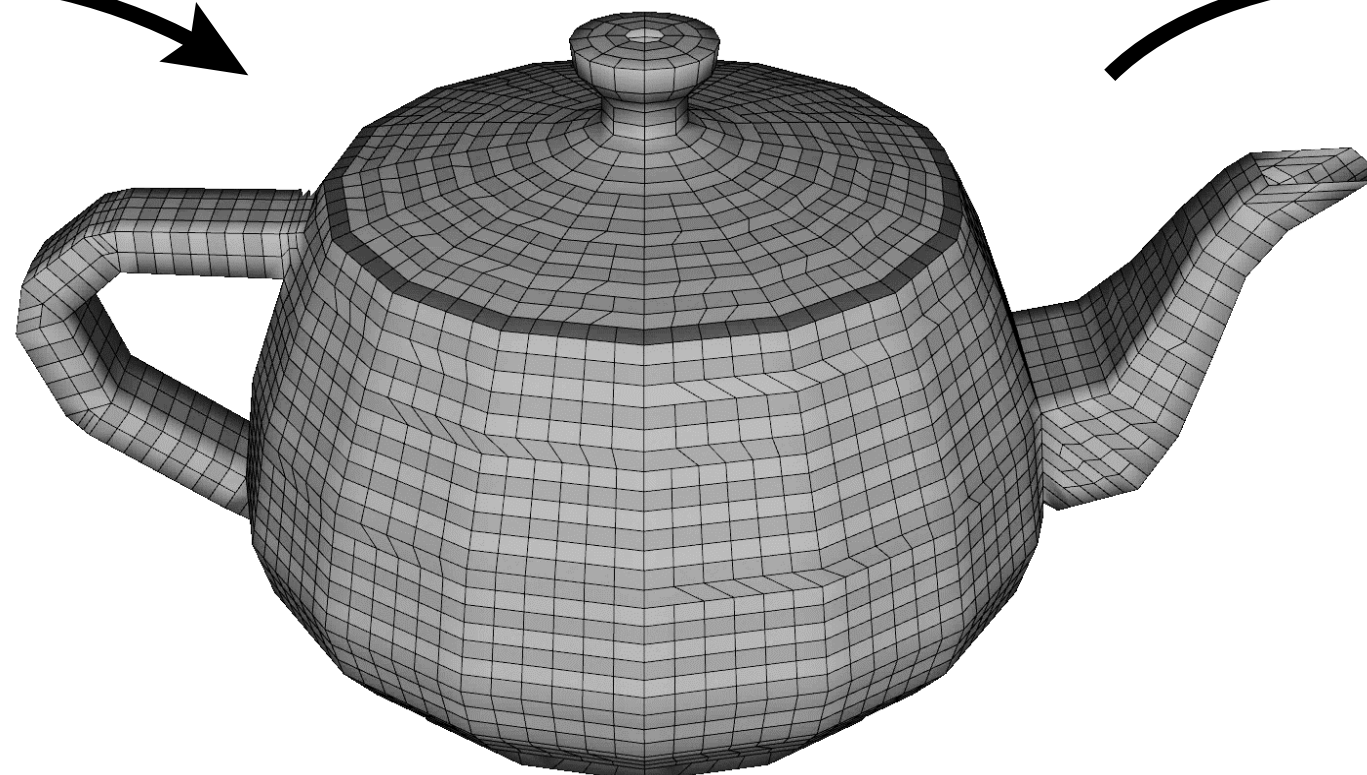

Stitch mesh

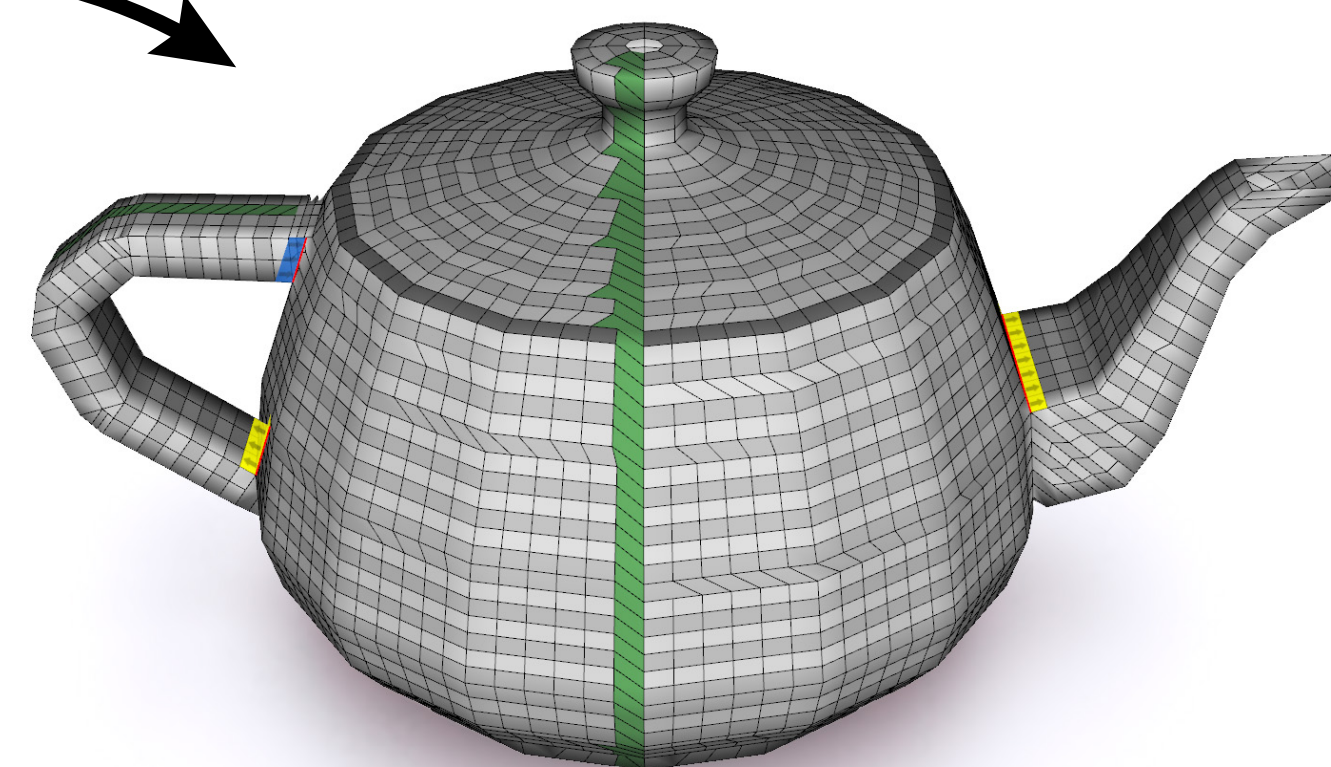

Knittable stitch mesh

# Knittable Stitch Mesh

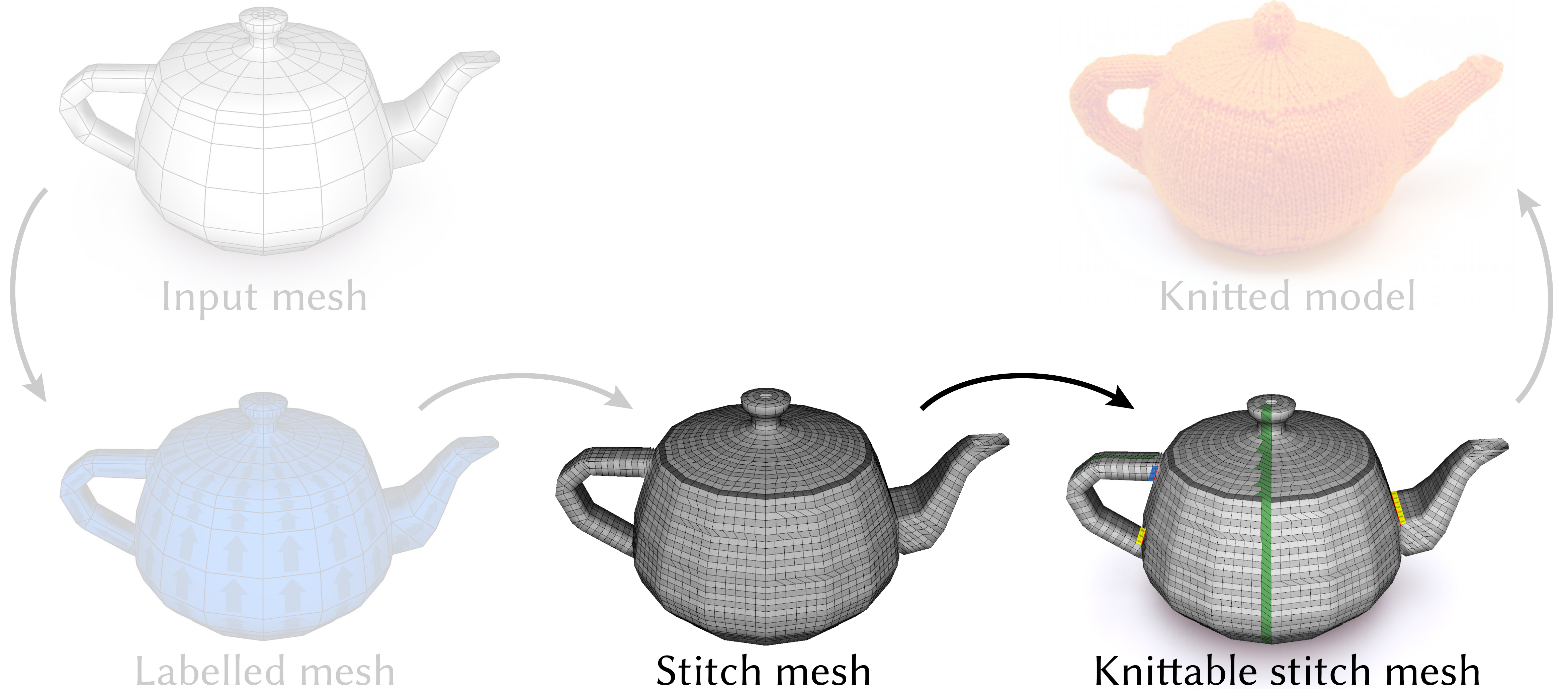

# Knittable Stitch Mesh

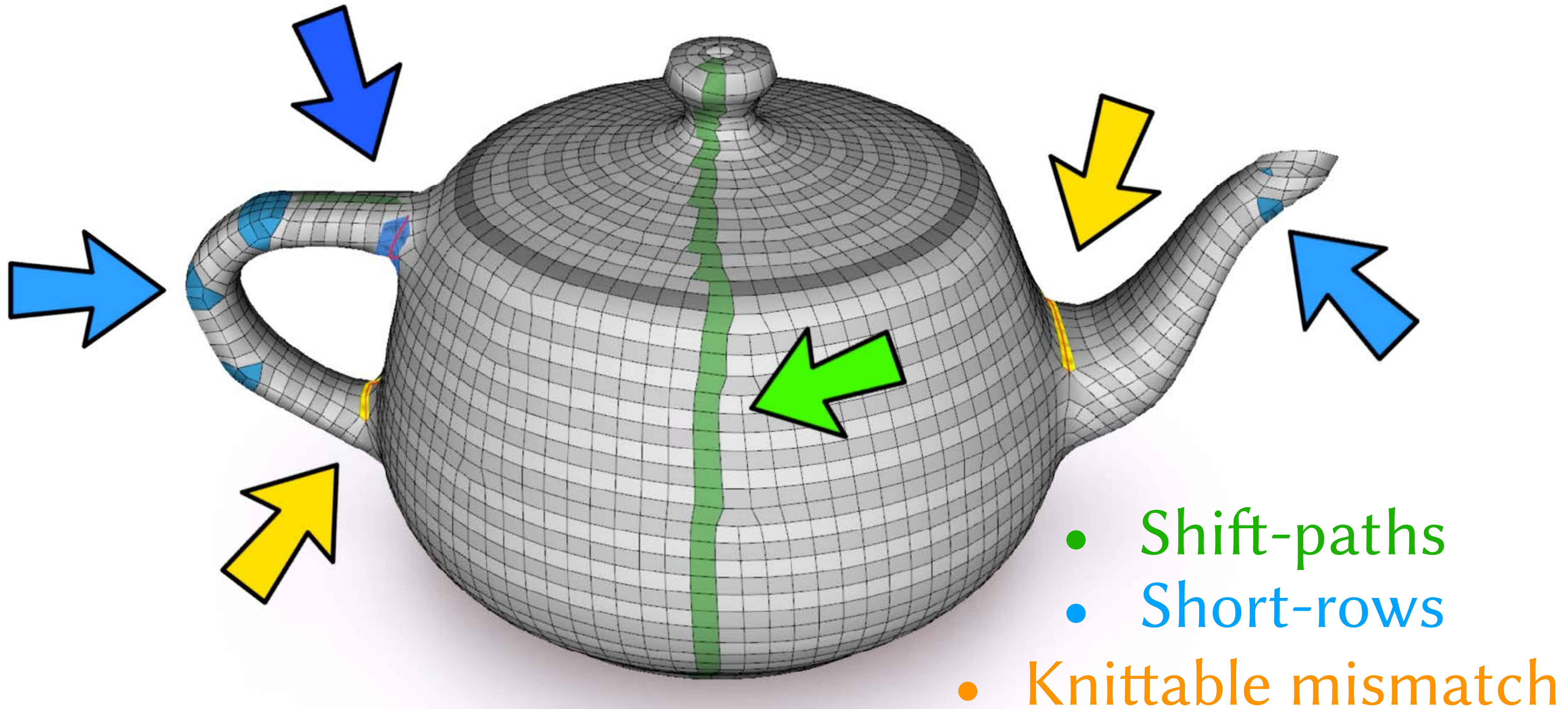



# Shift-Paths

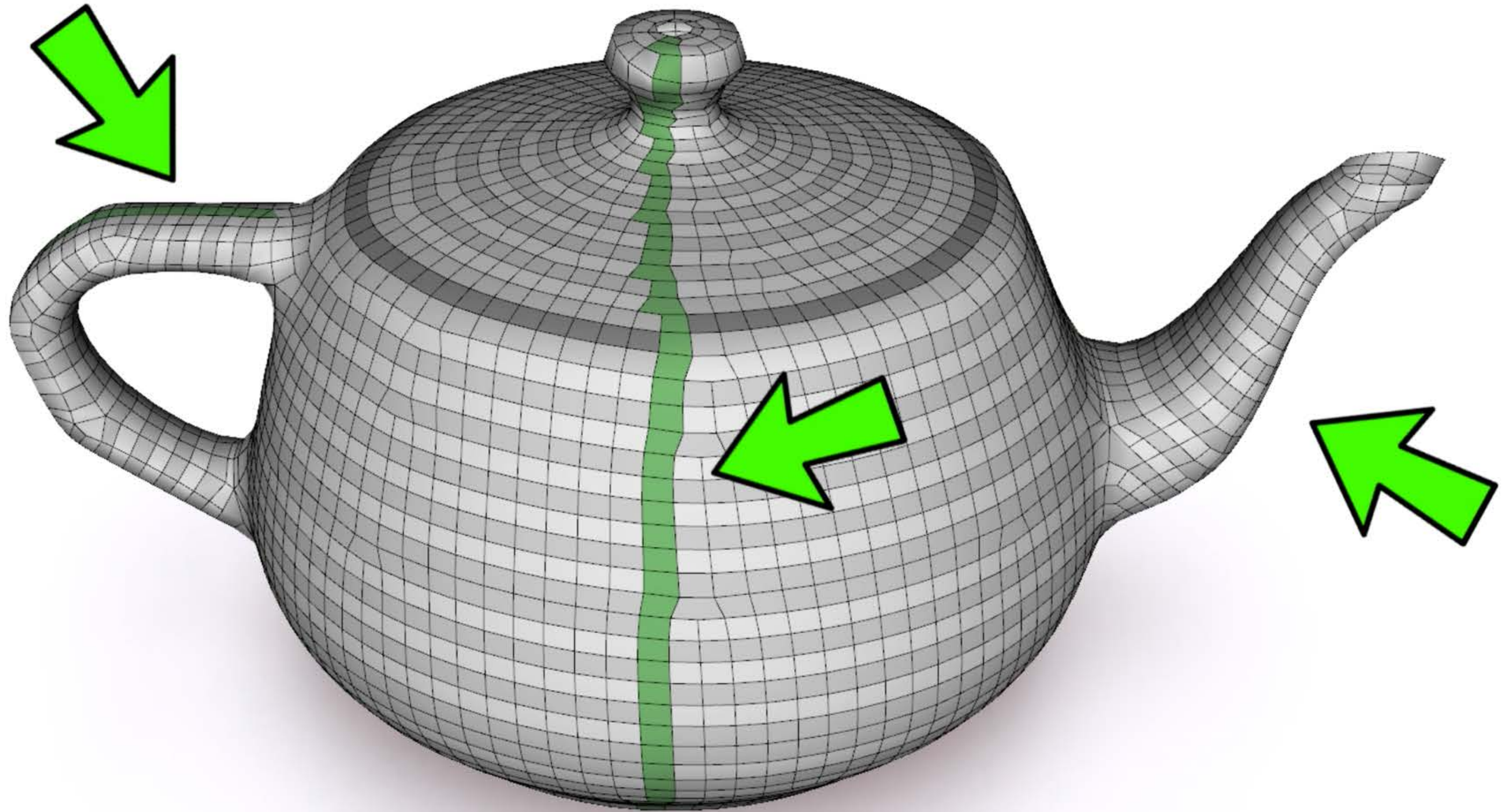

# Shift-Paths

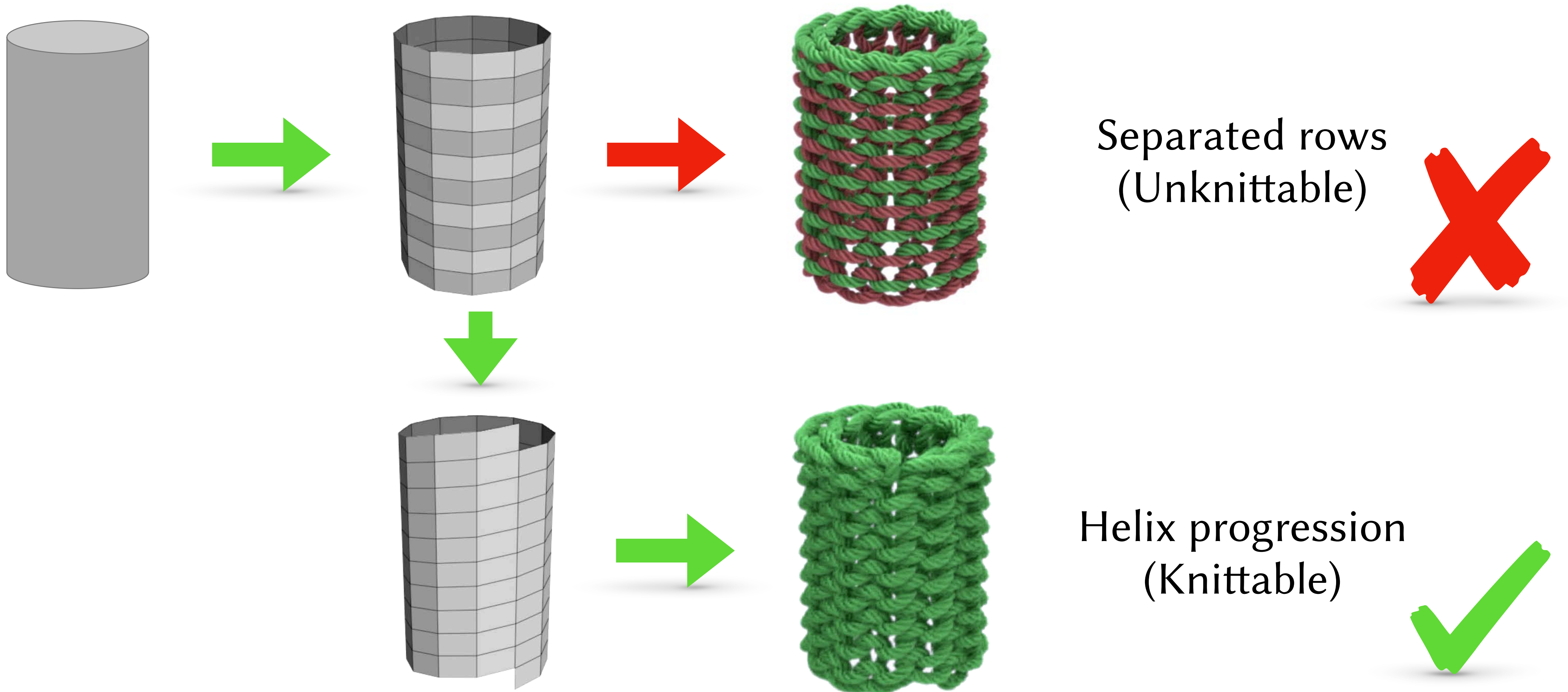

# Shift-Paths

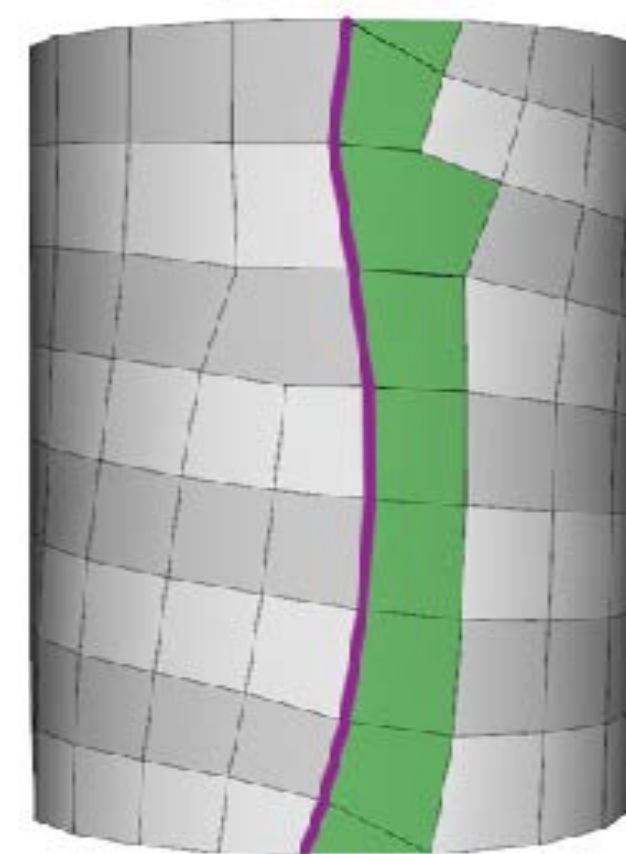
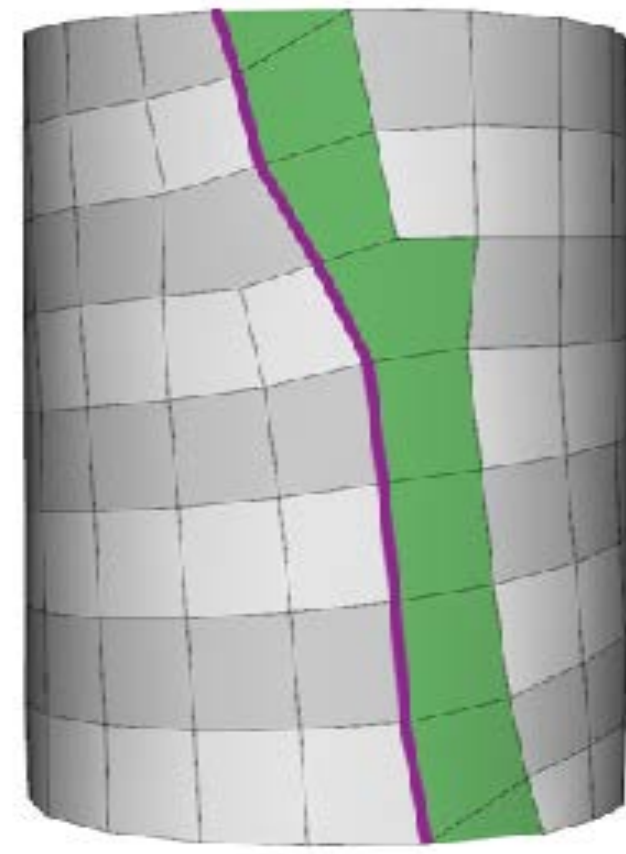
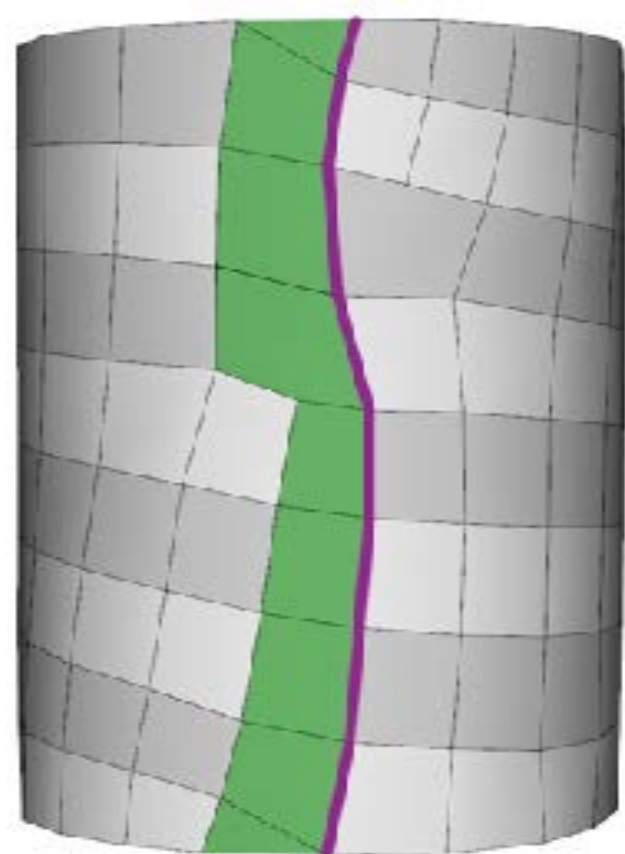
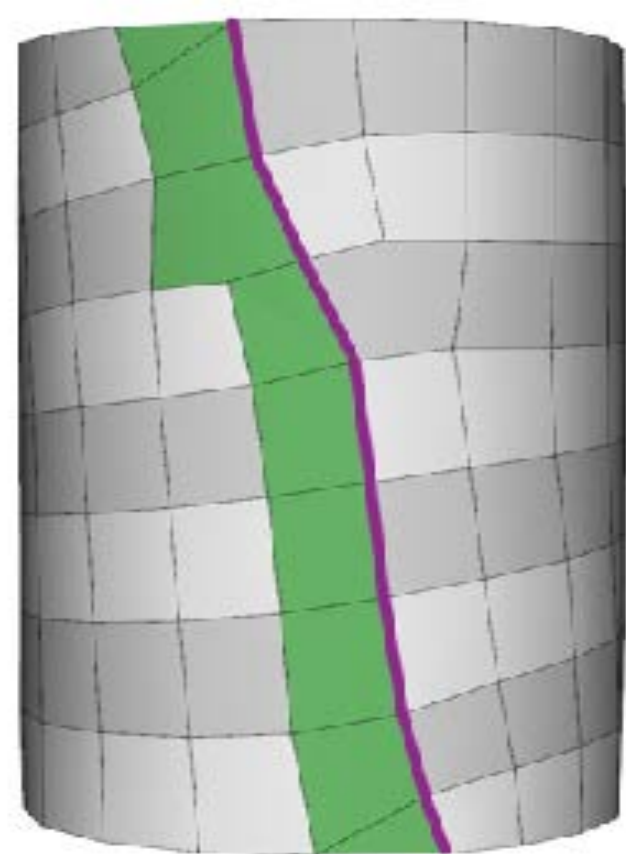
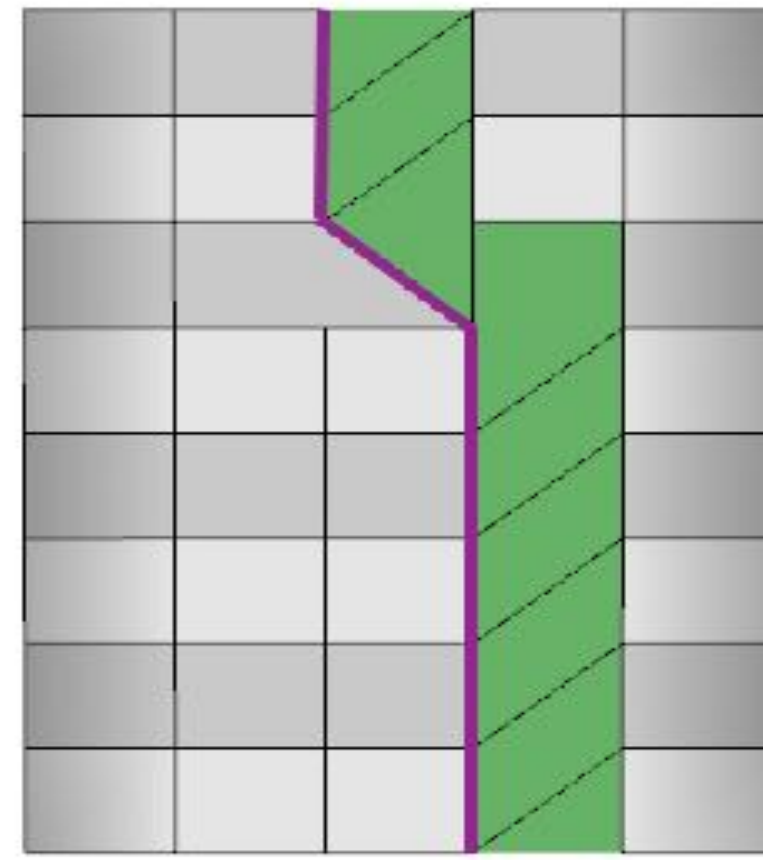
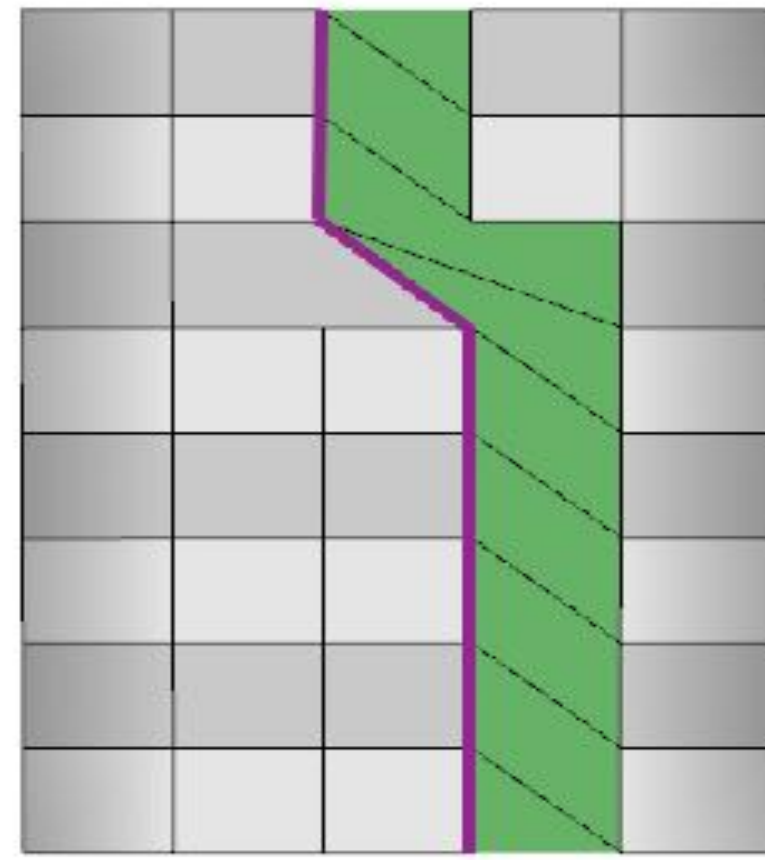
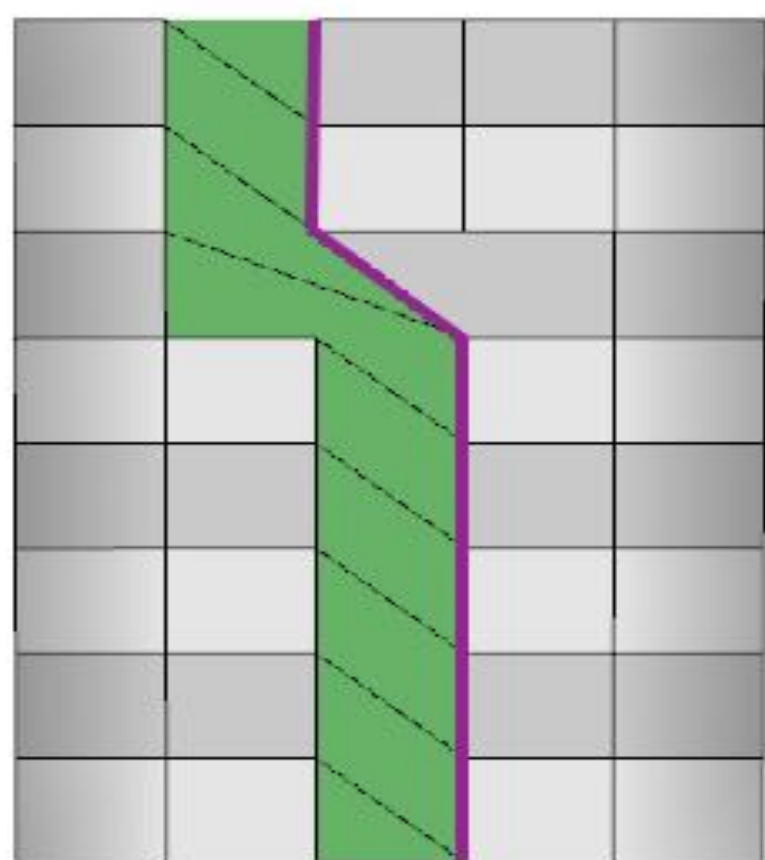
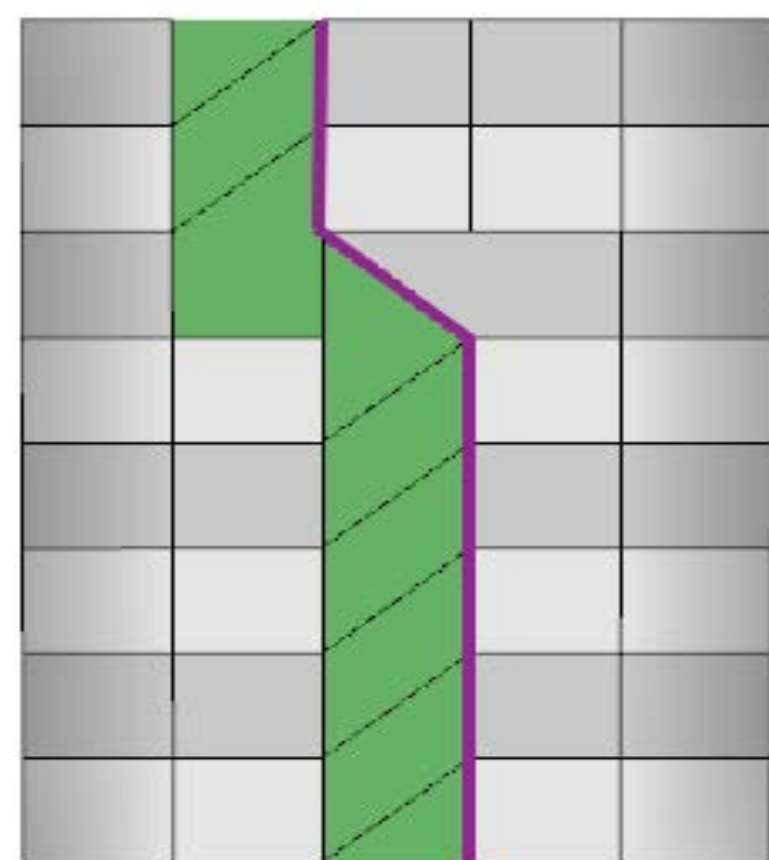
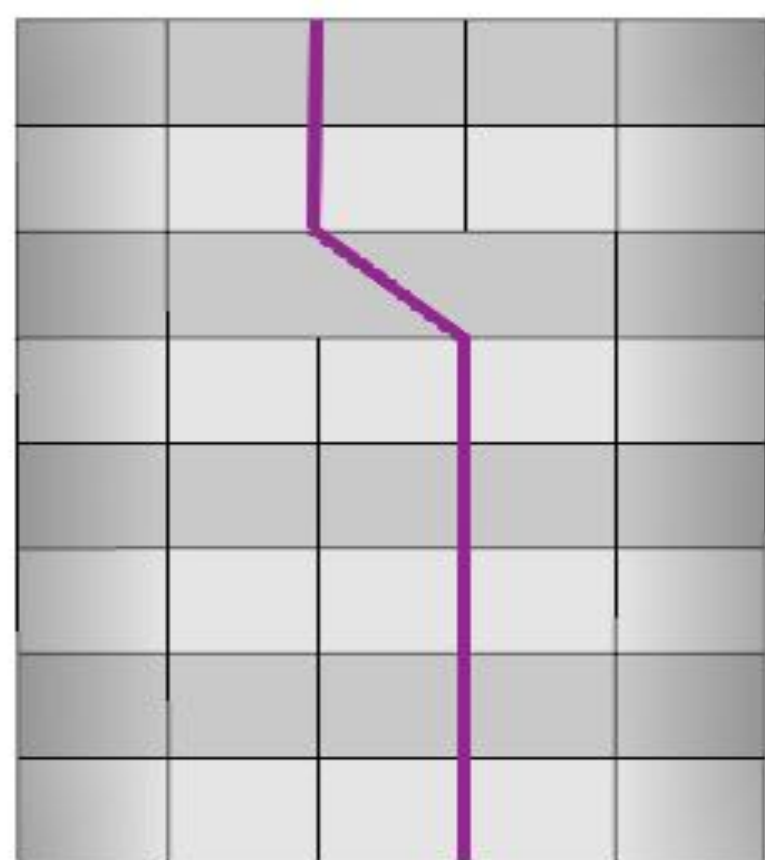

# Shift-Paths

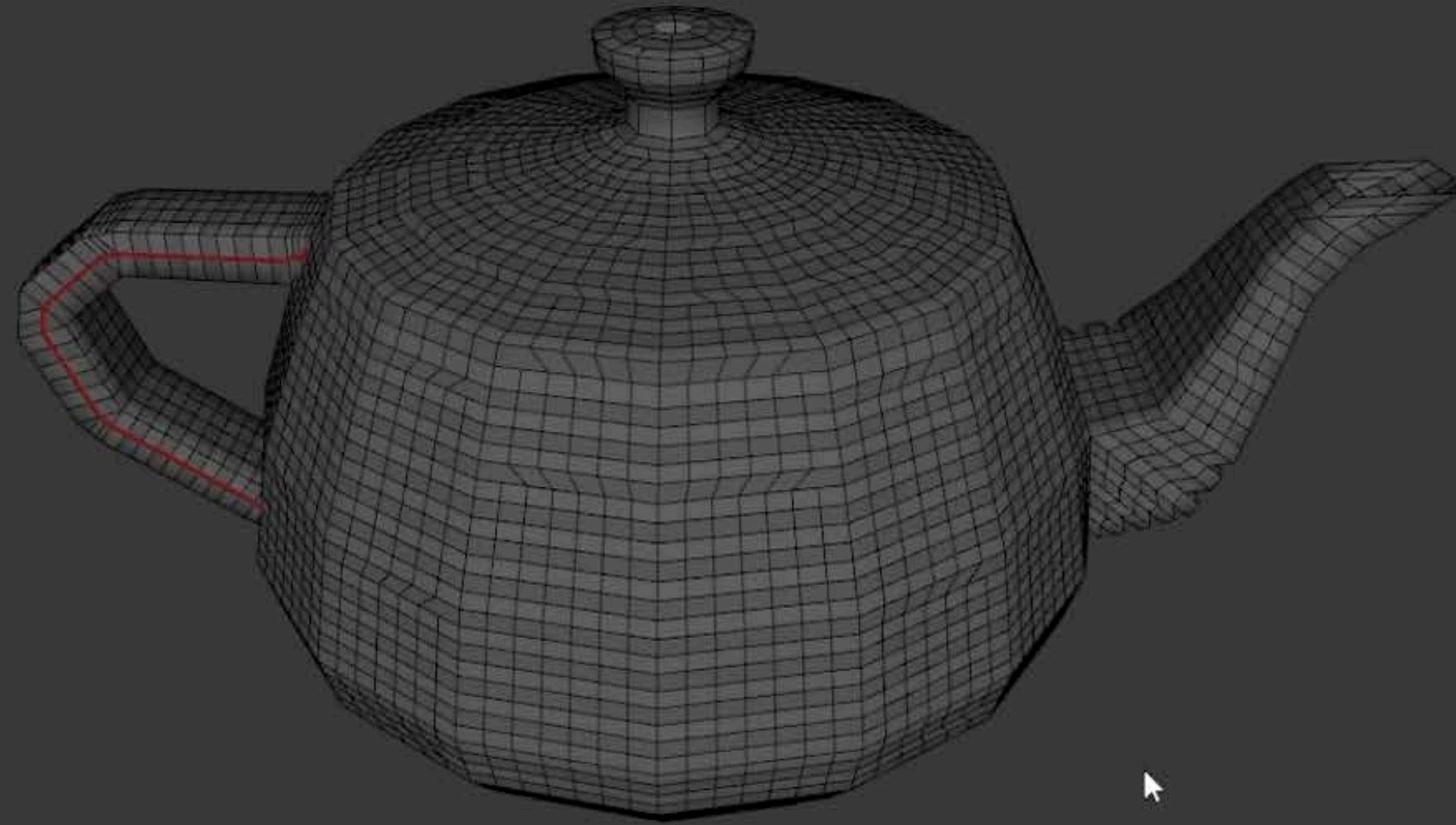

# Shift-Paths

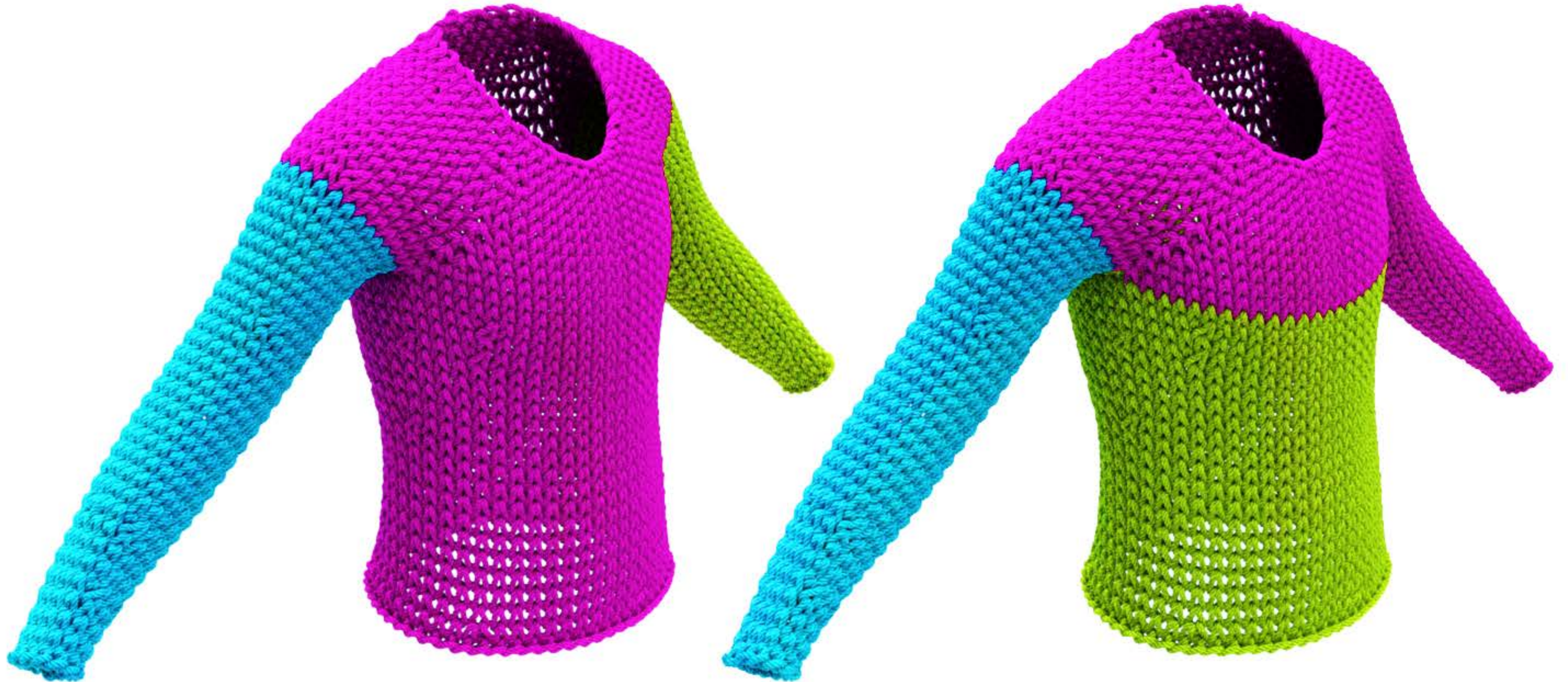

# Knittable *Mismatched* Directions

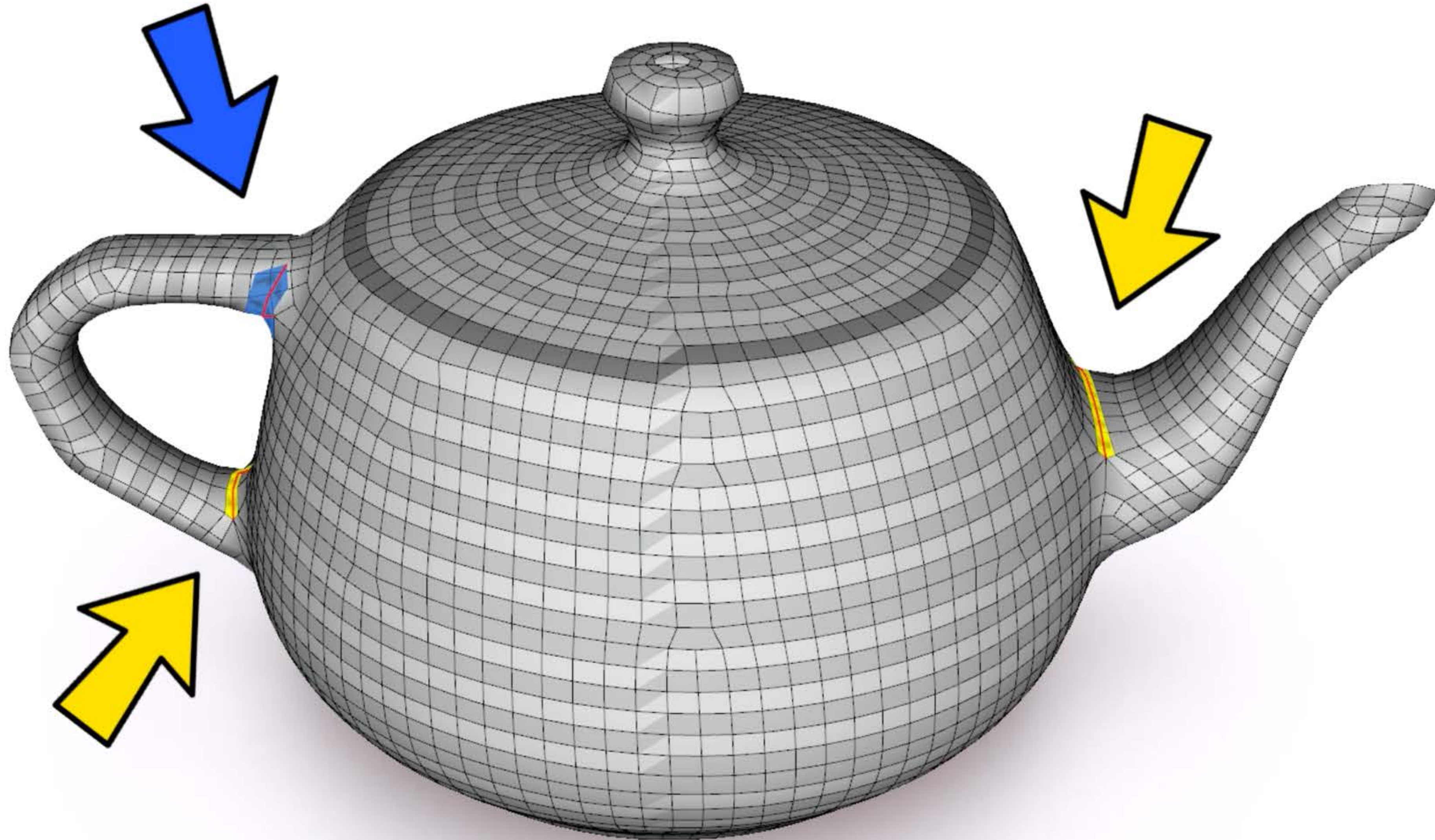

# Knittable Mismatched Directions

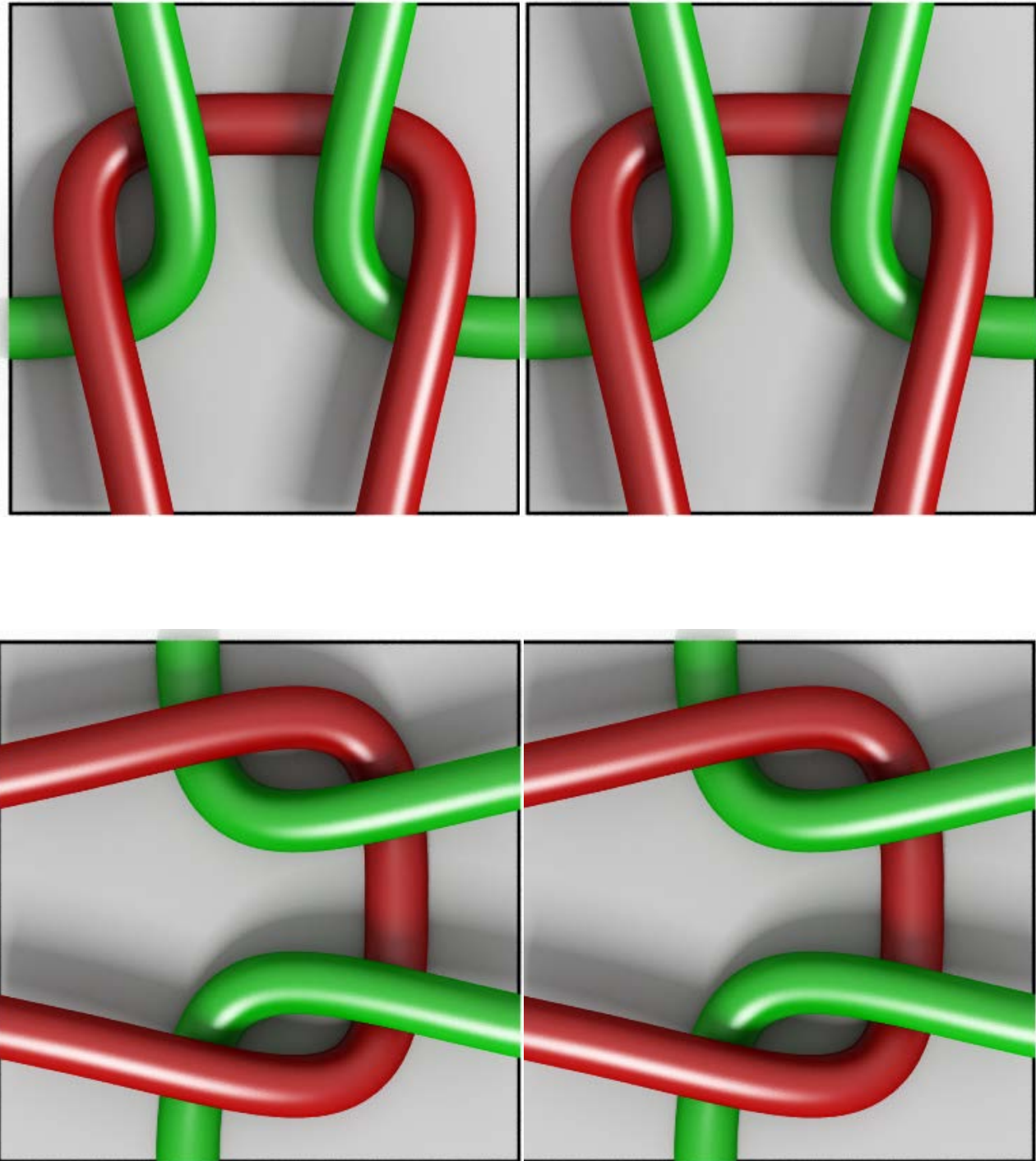
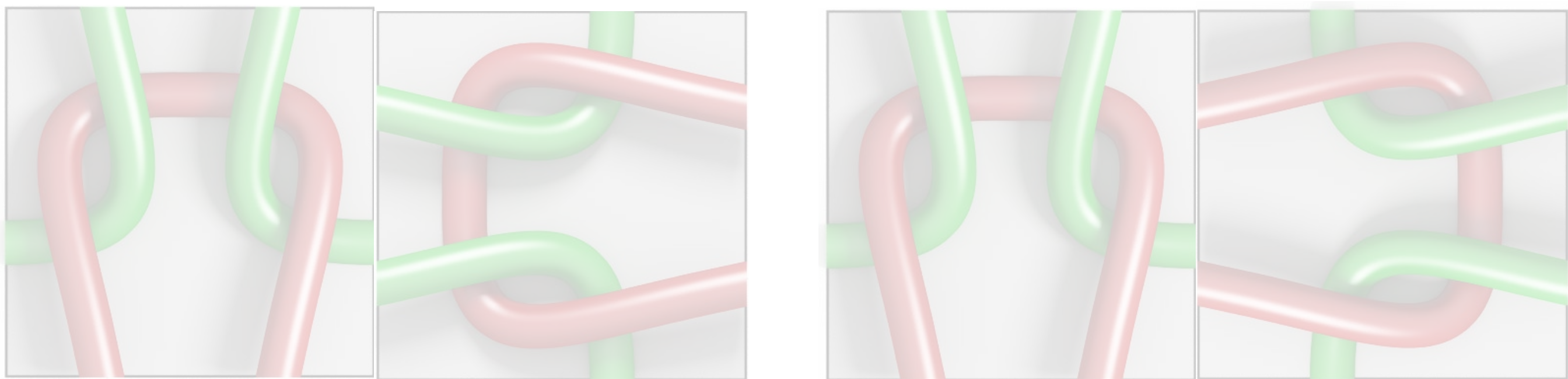
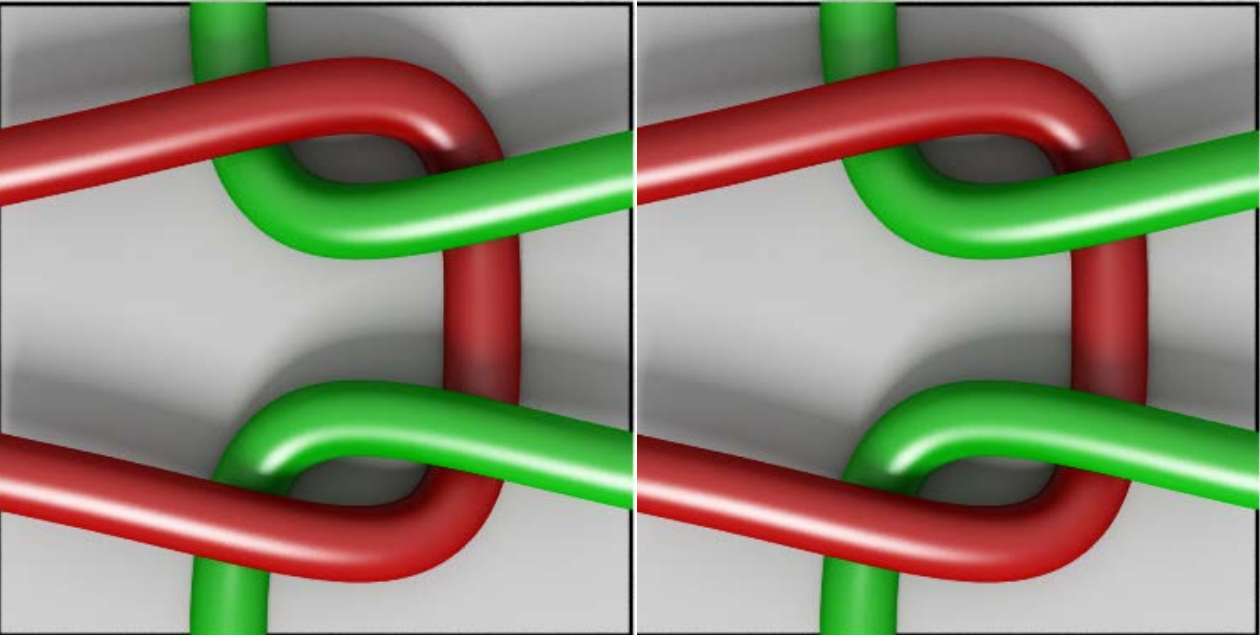
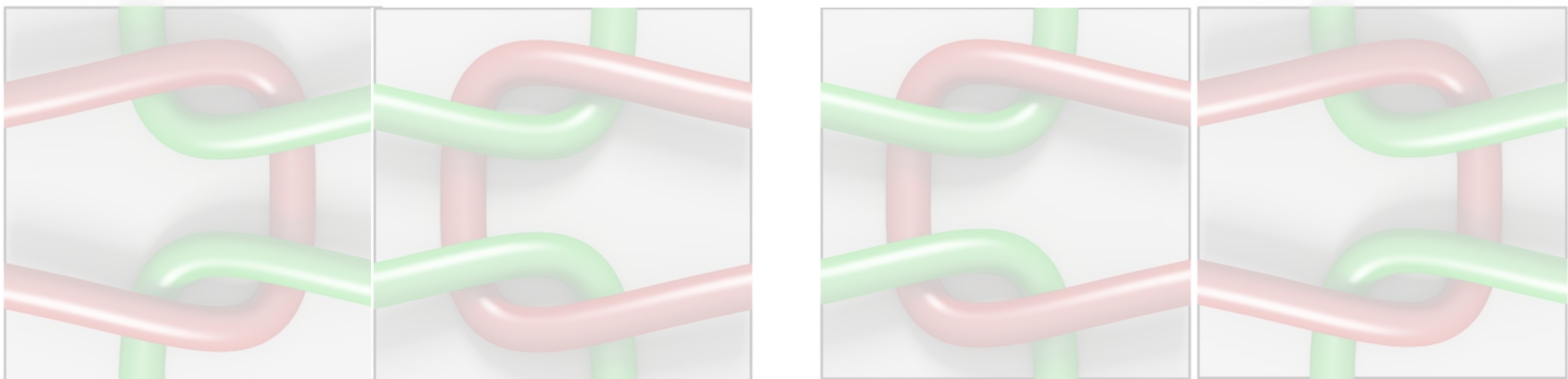
Consistent	Mismatched knitting direction
	
	

# Knittable Mismatched Directions

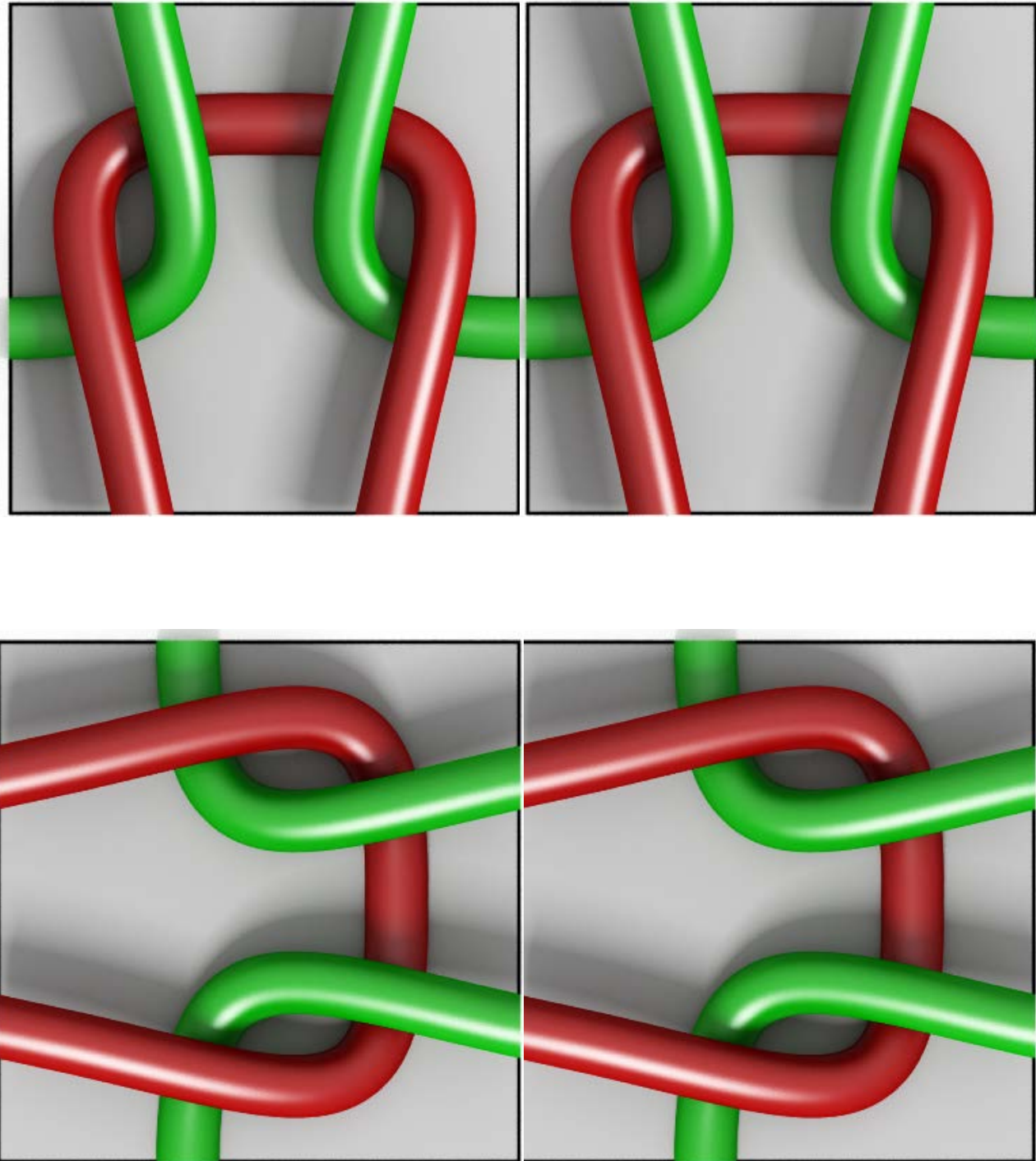
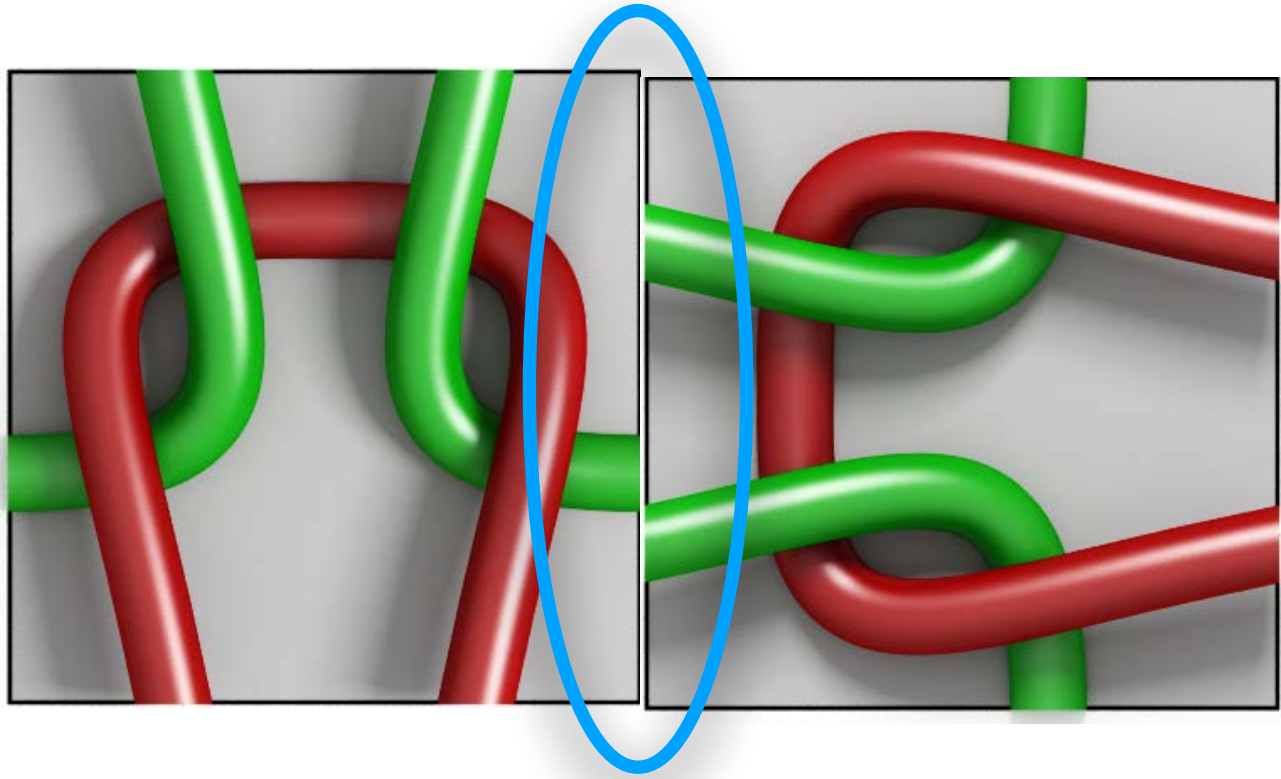
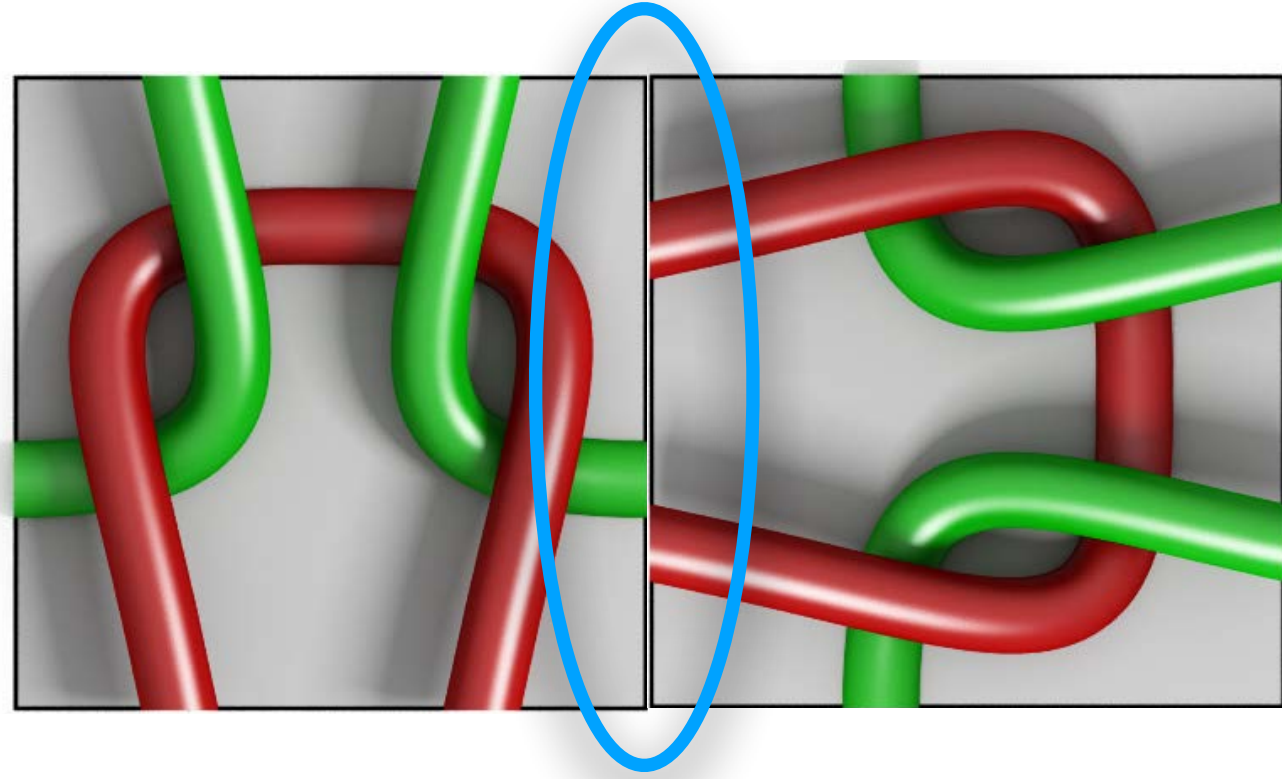
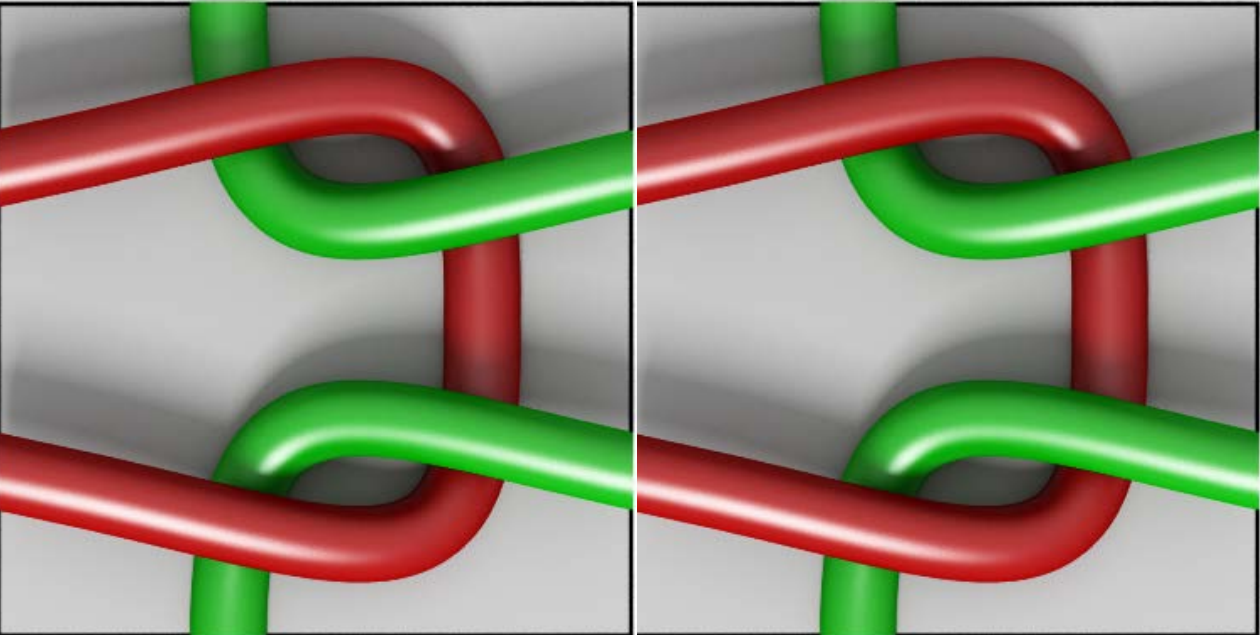
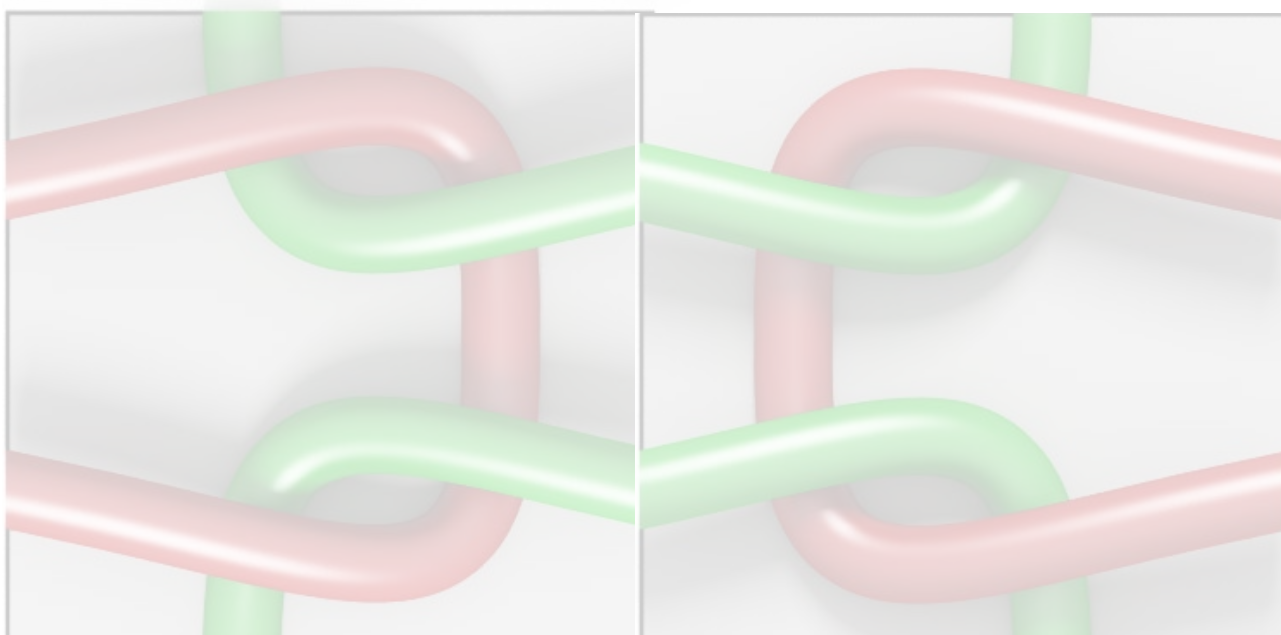
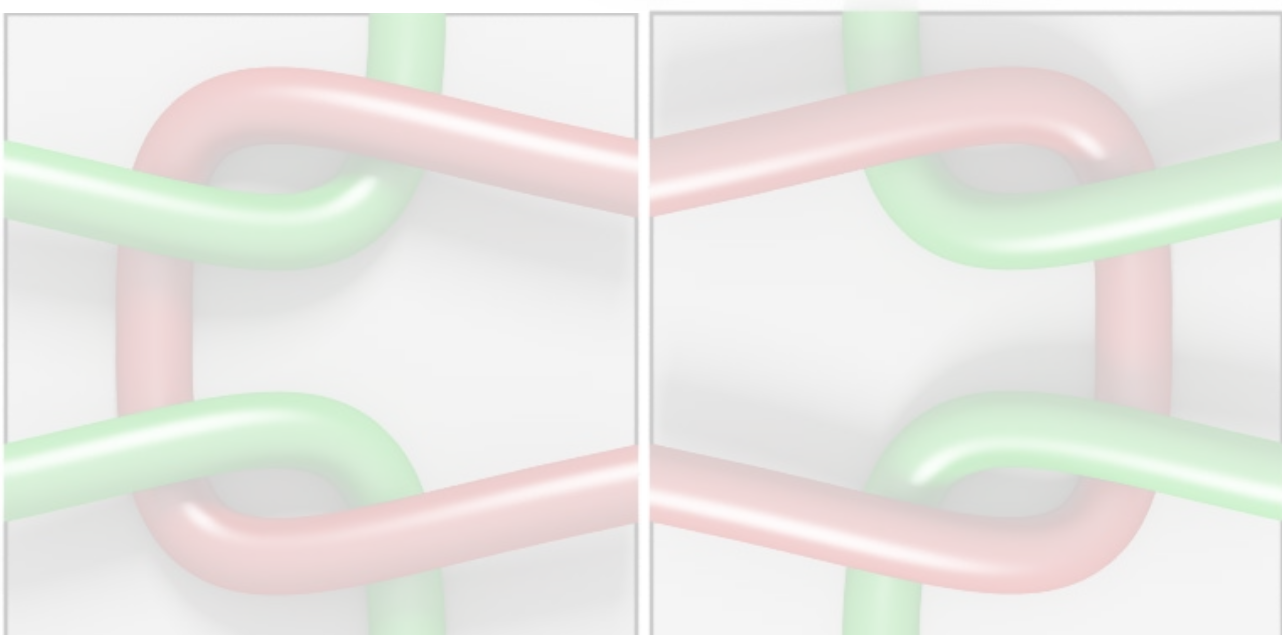
Consistent	Mismatched knitting direction	
		
		

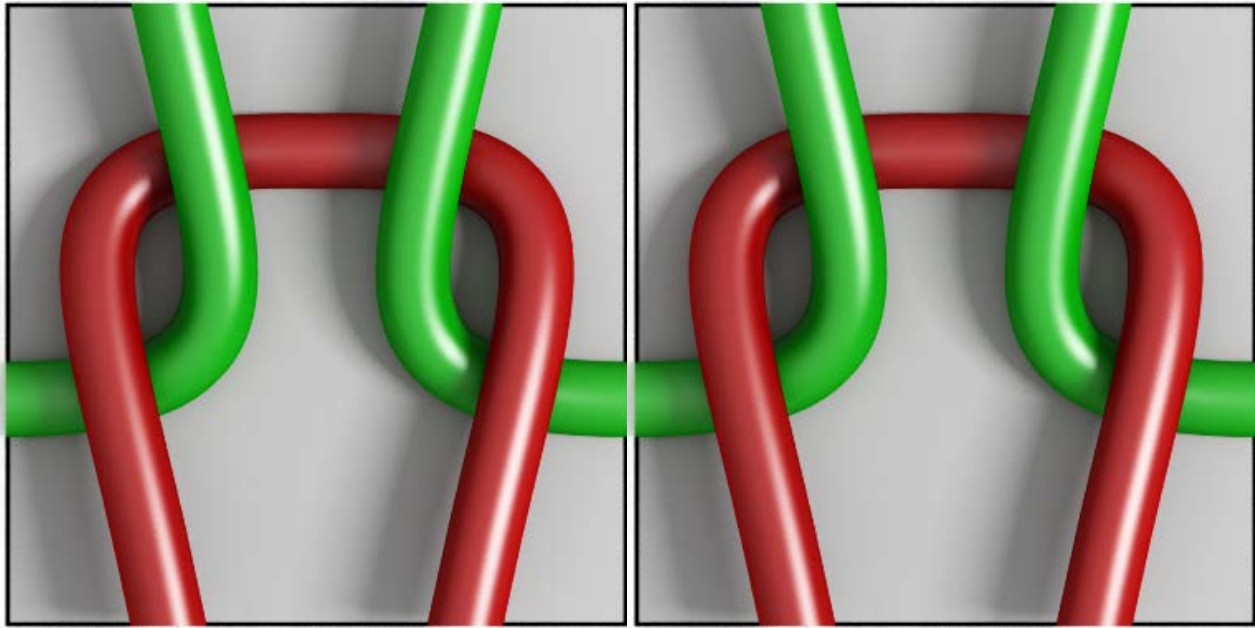
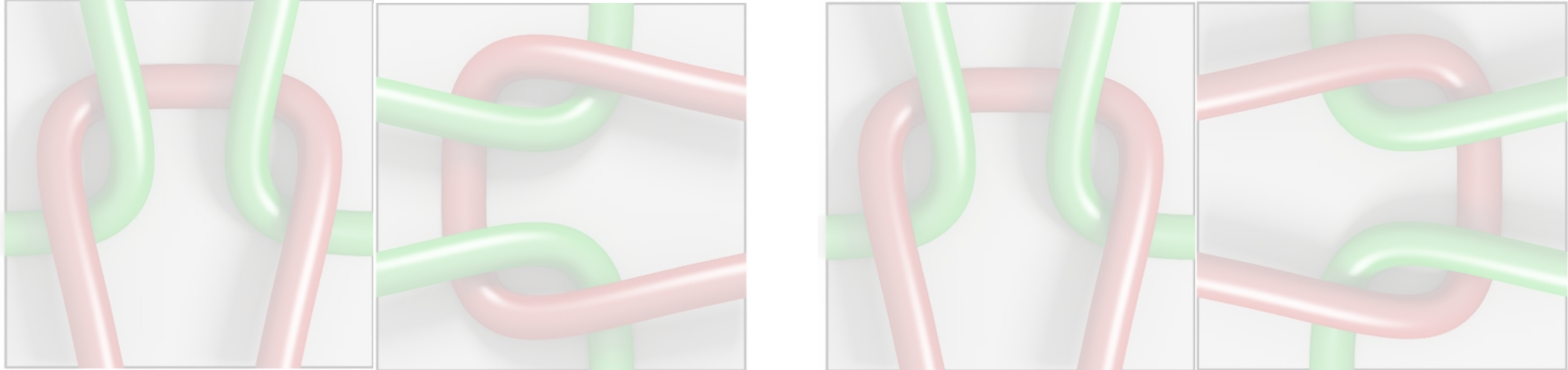
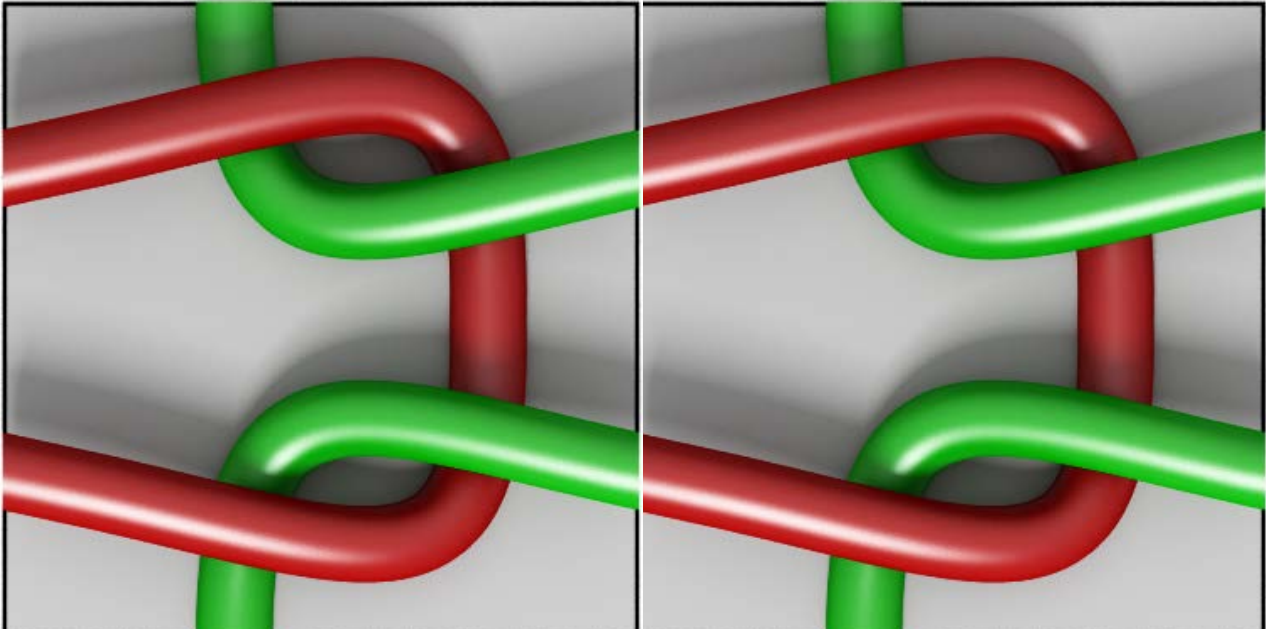
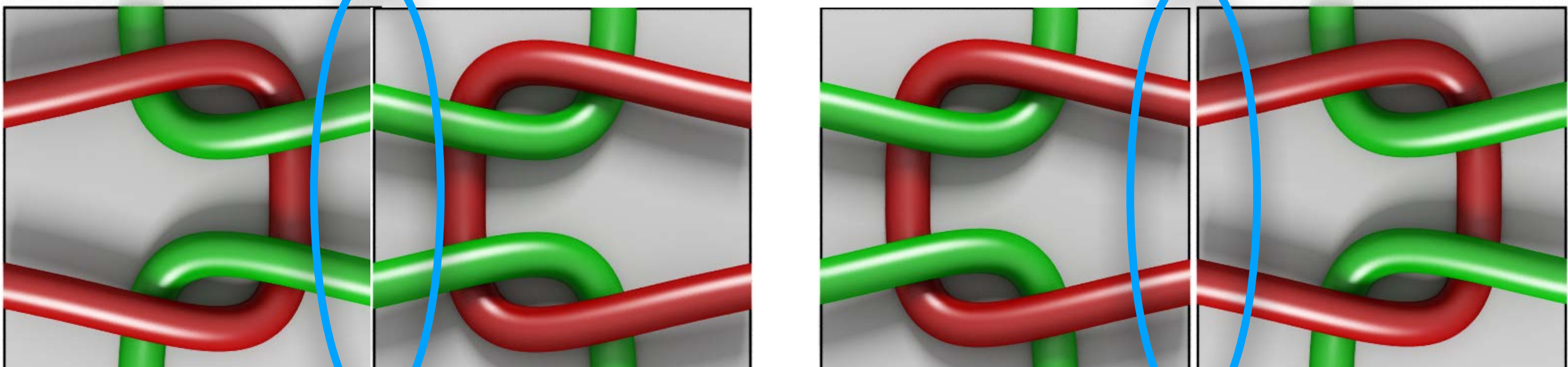

# Knittable Mismatched Directions

Consistent	Mismatched knitting direction	
		
		

# Knittable Mismatched Directions

## Splitting

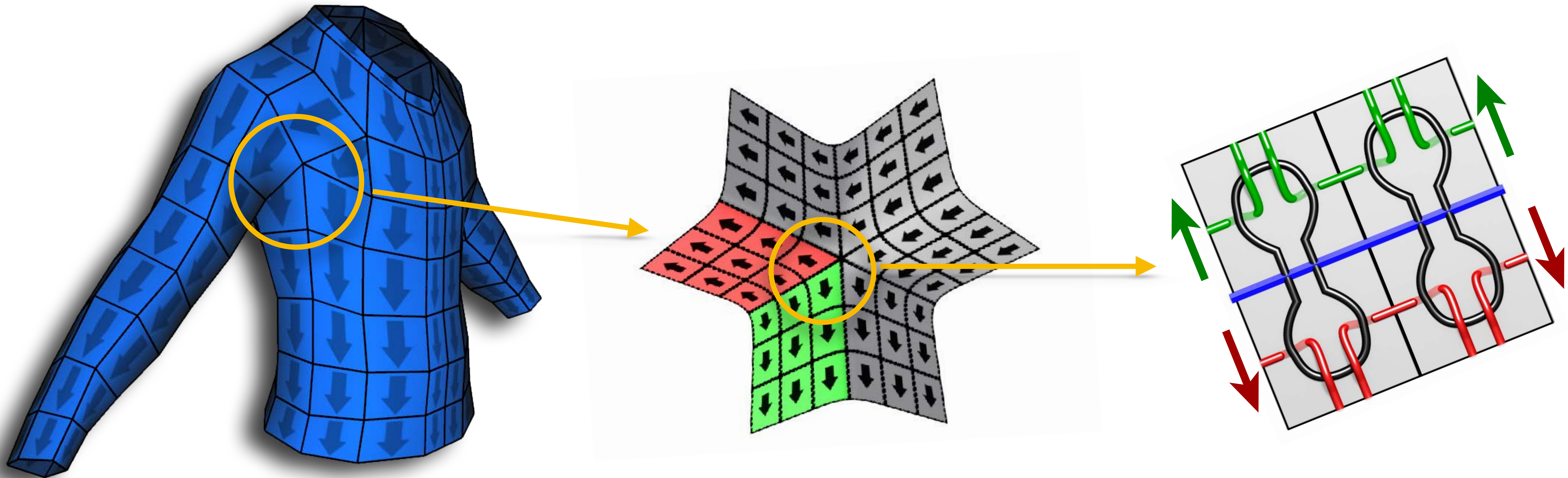

# Knittable Mismatched Directions

Splitting

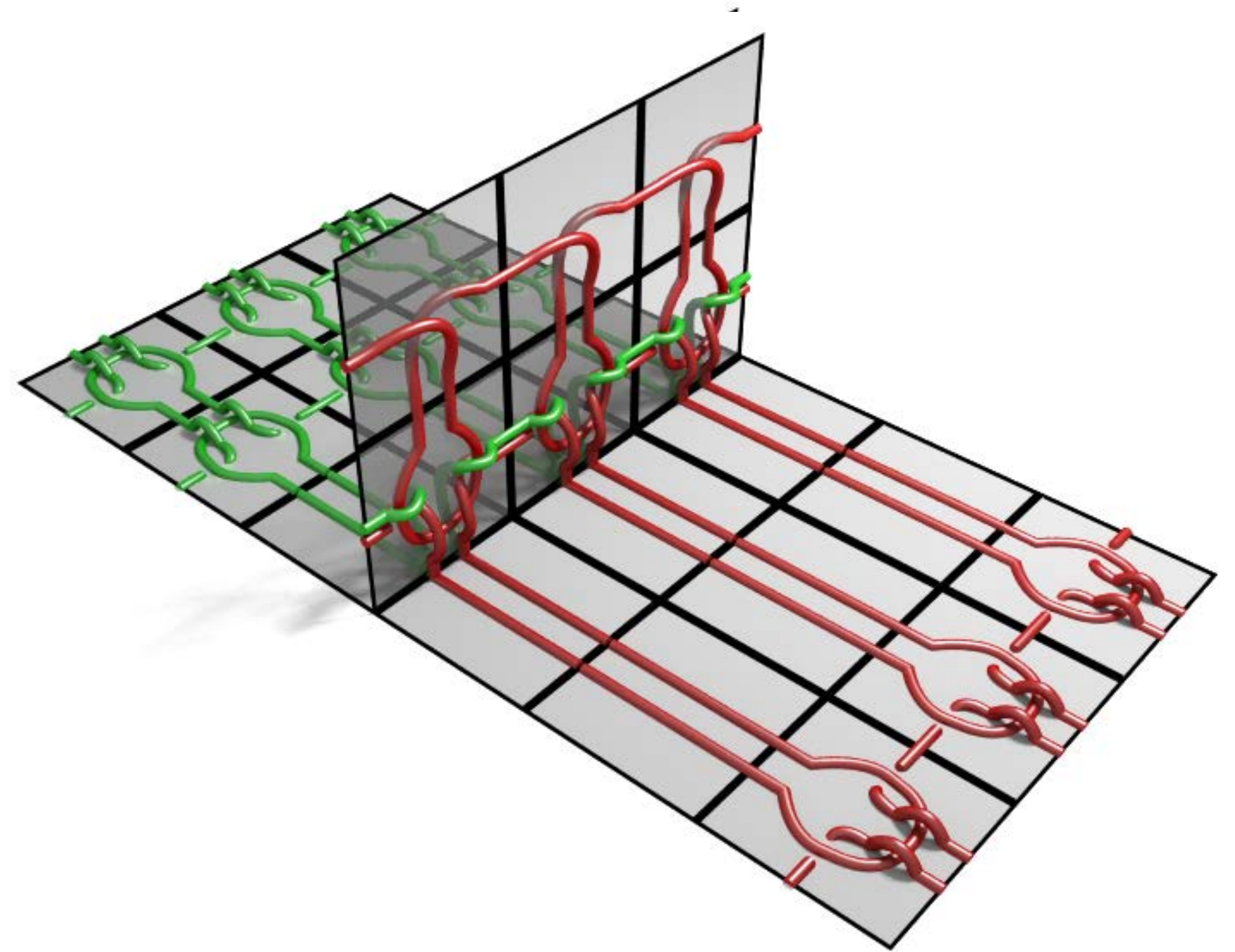
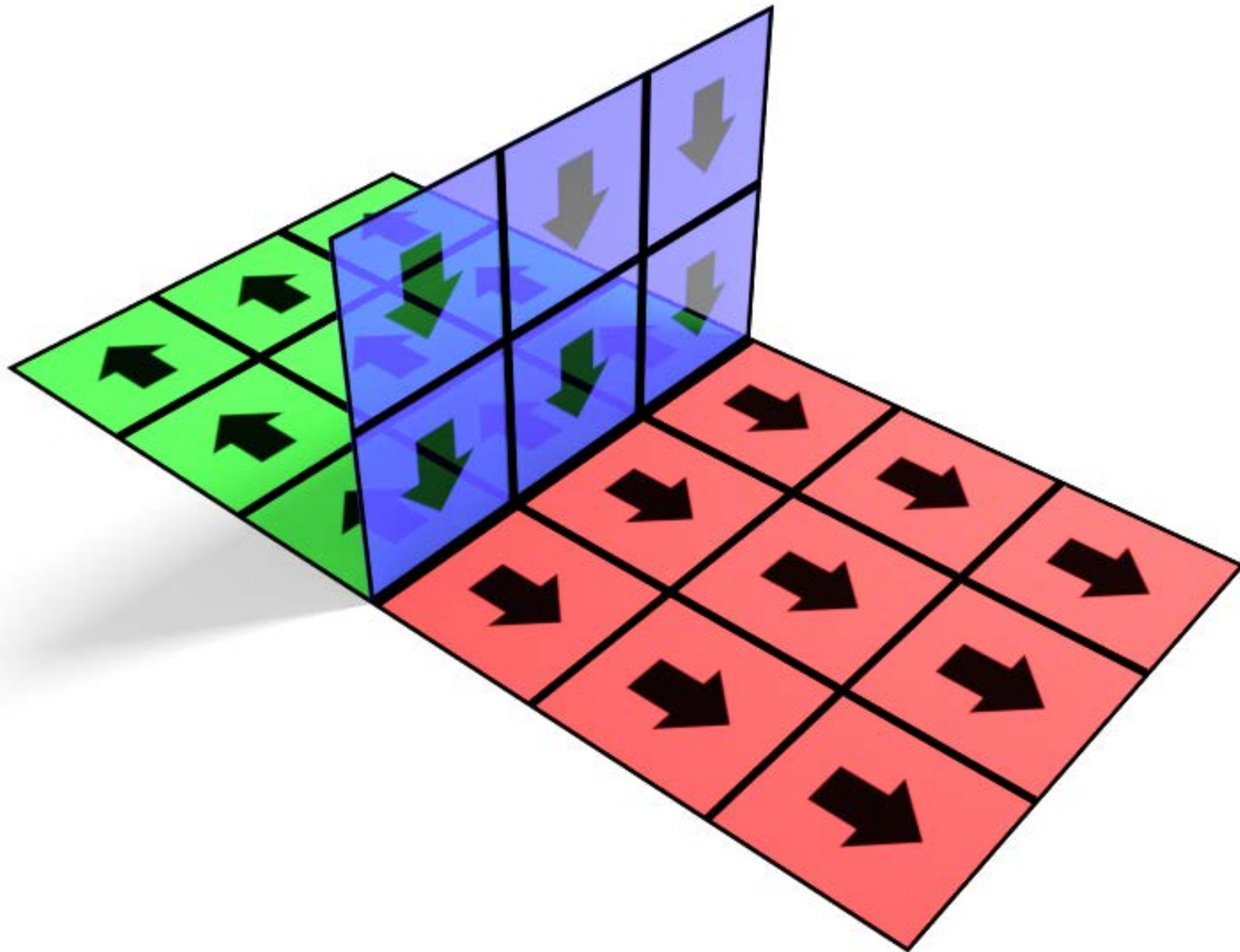

# Knittable *Mismatched* Directions

Joining

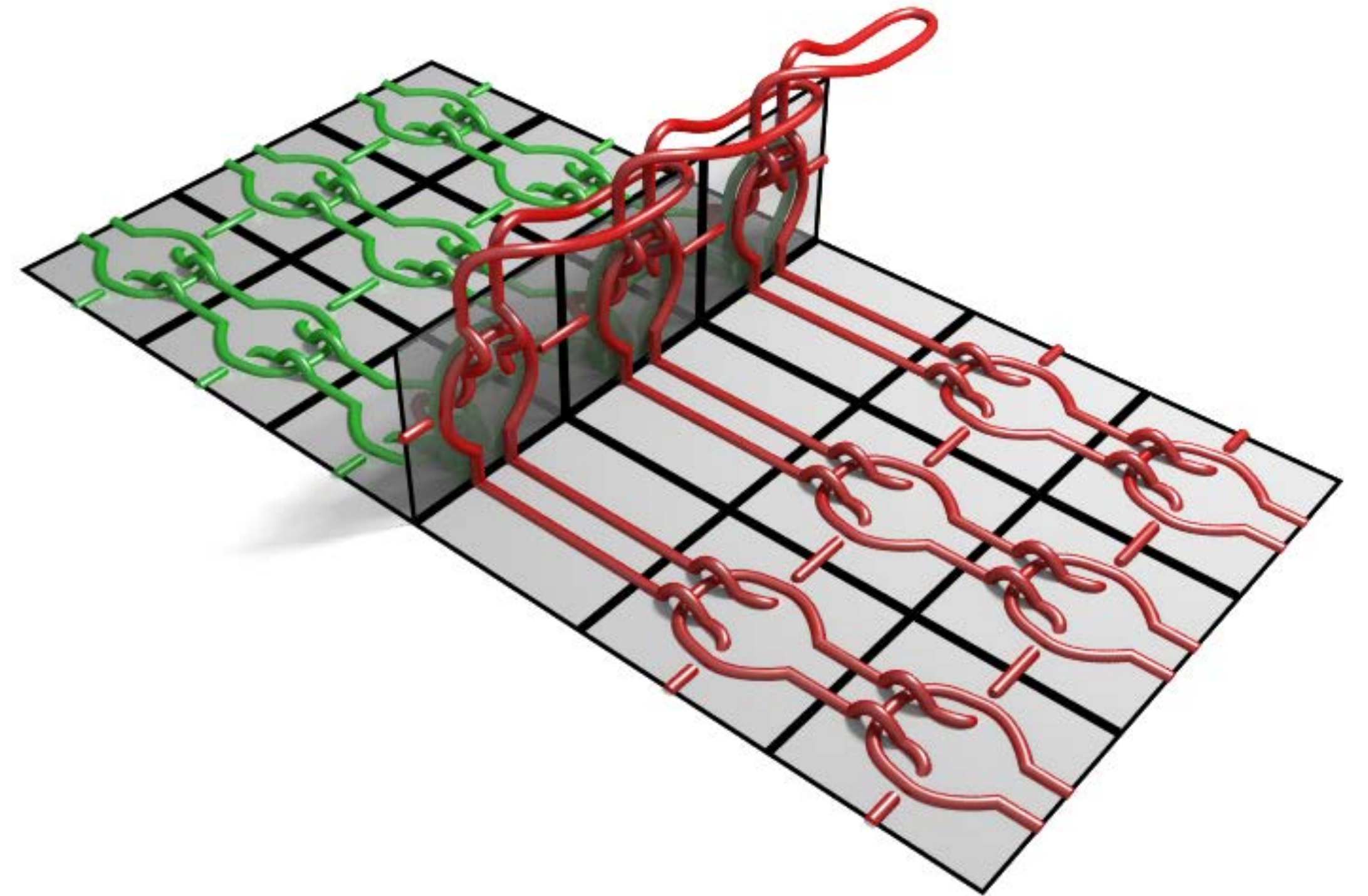
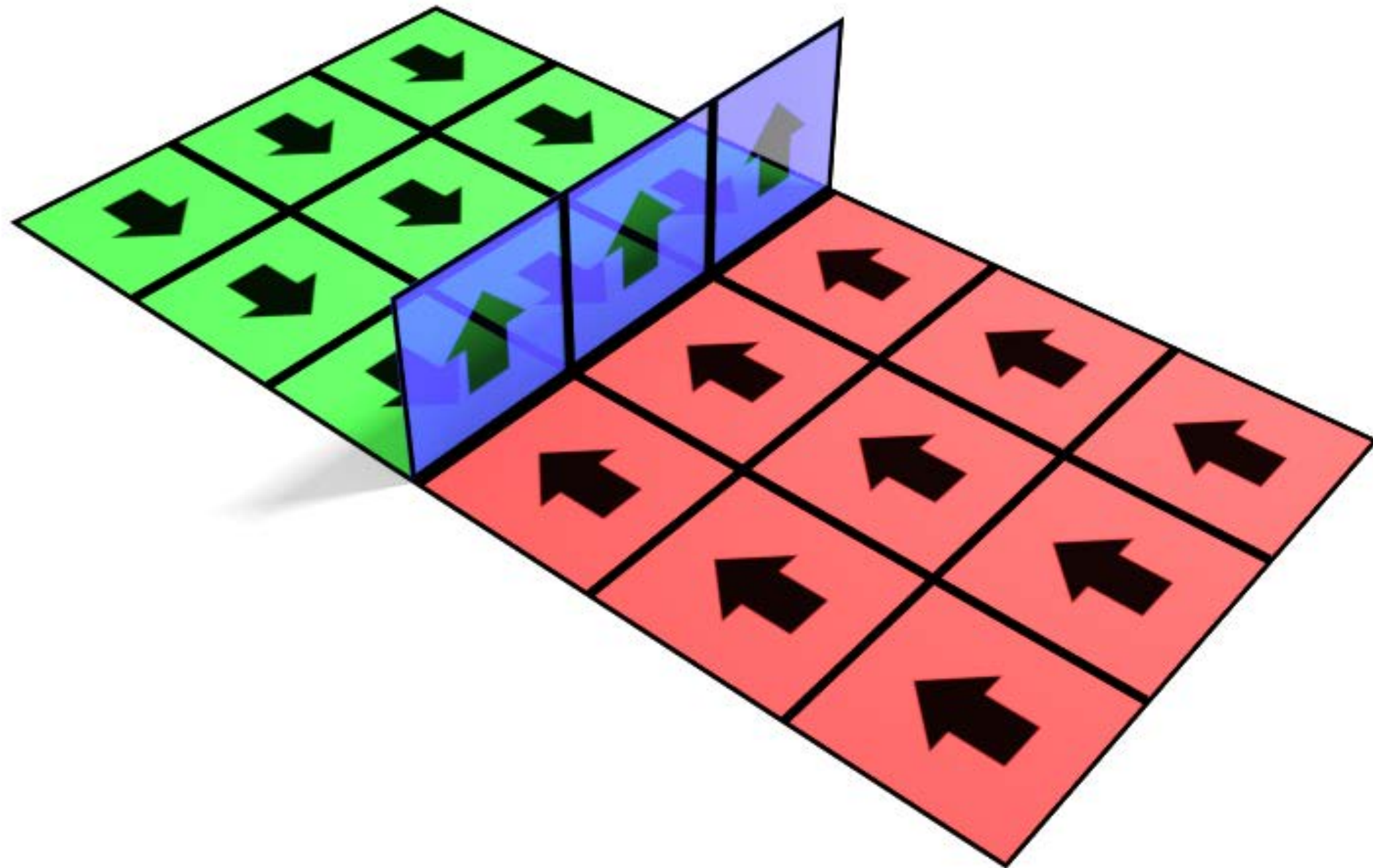

# Knittable Mismatched Directions

Contracting

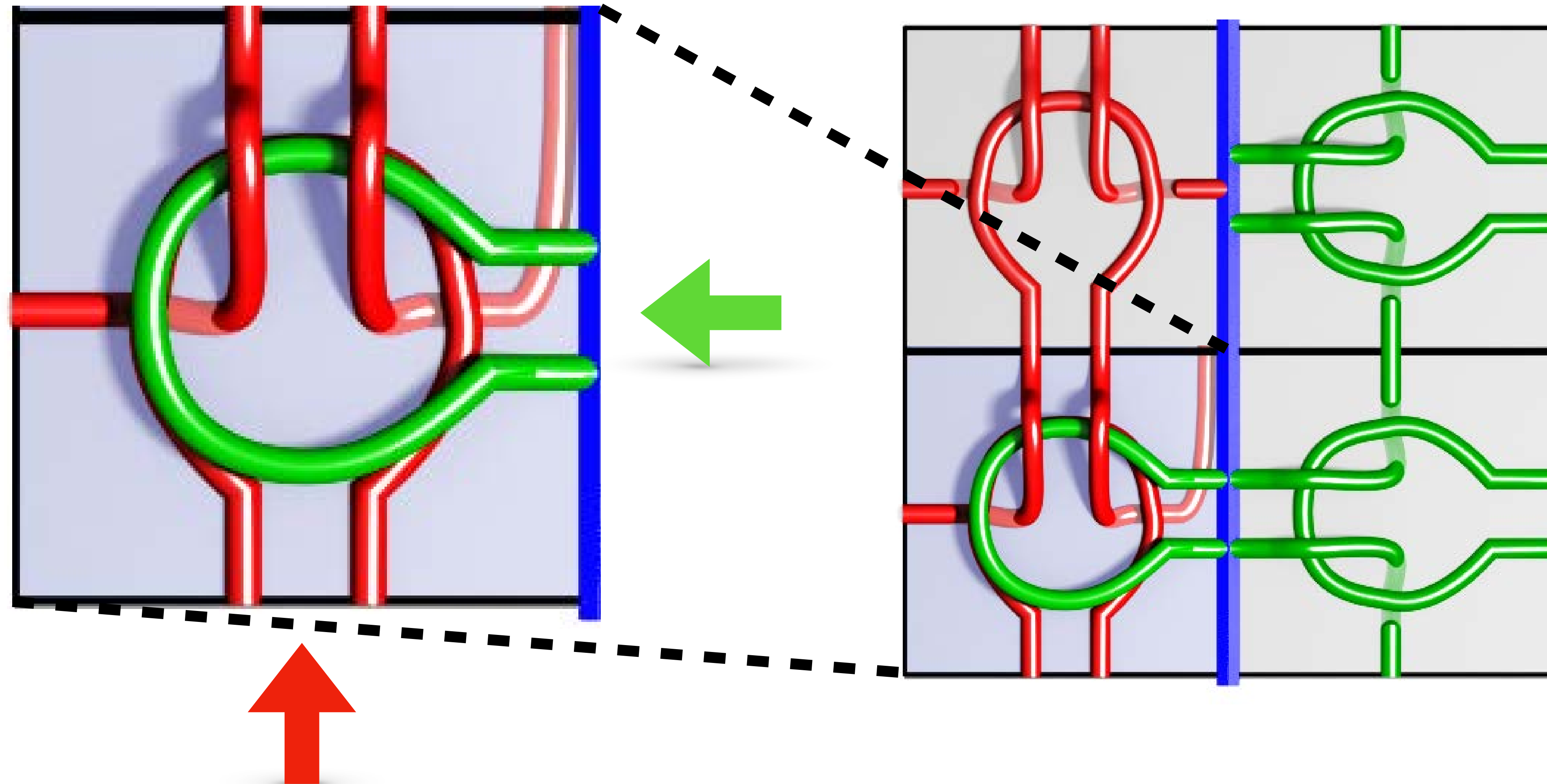

# Knittable Mismatched Directions

Contracting

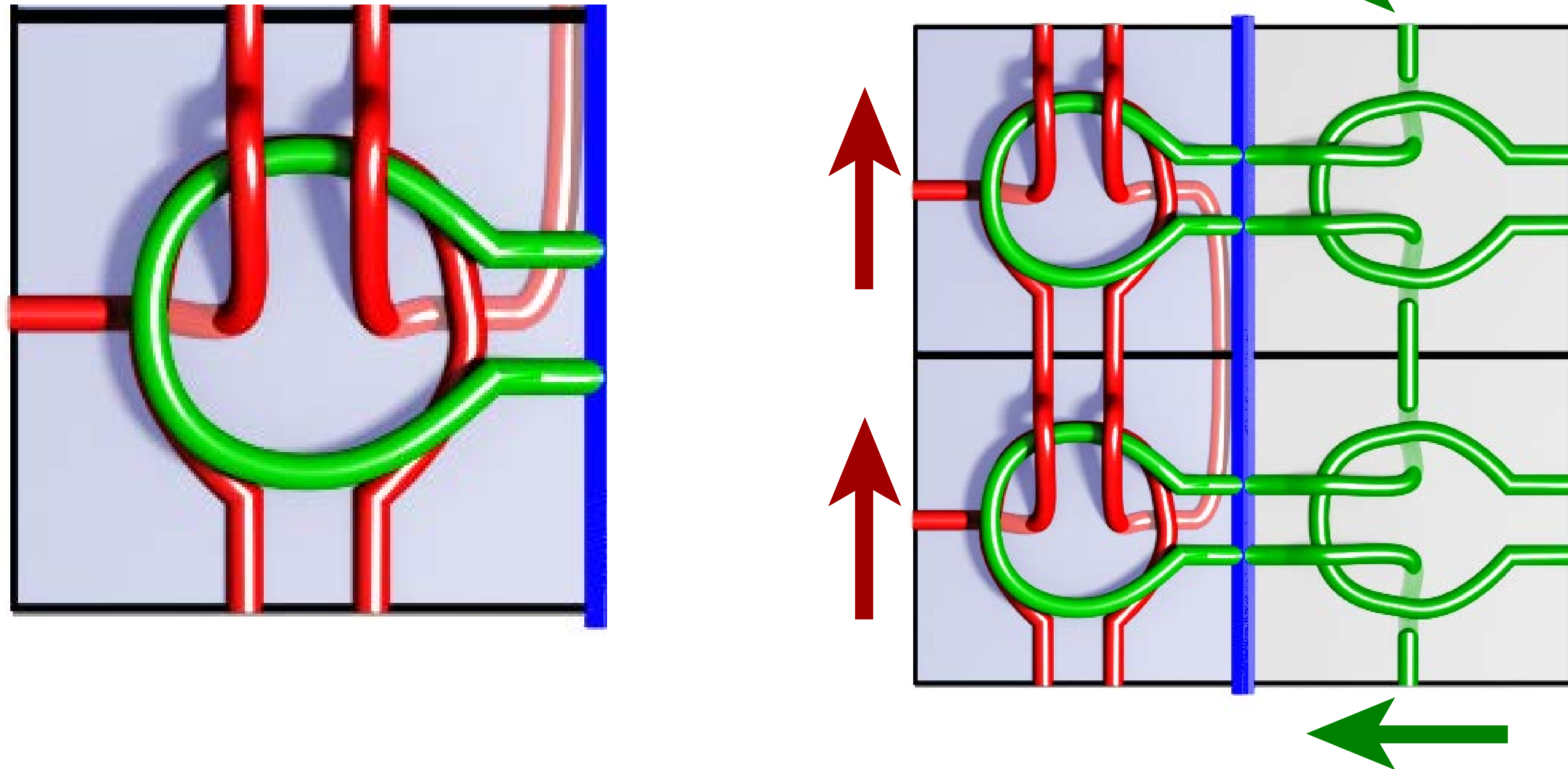

# Knittable Mismatched Directions

Expanding

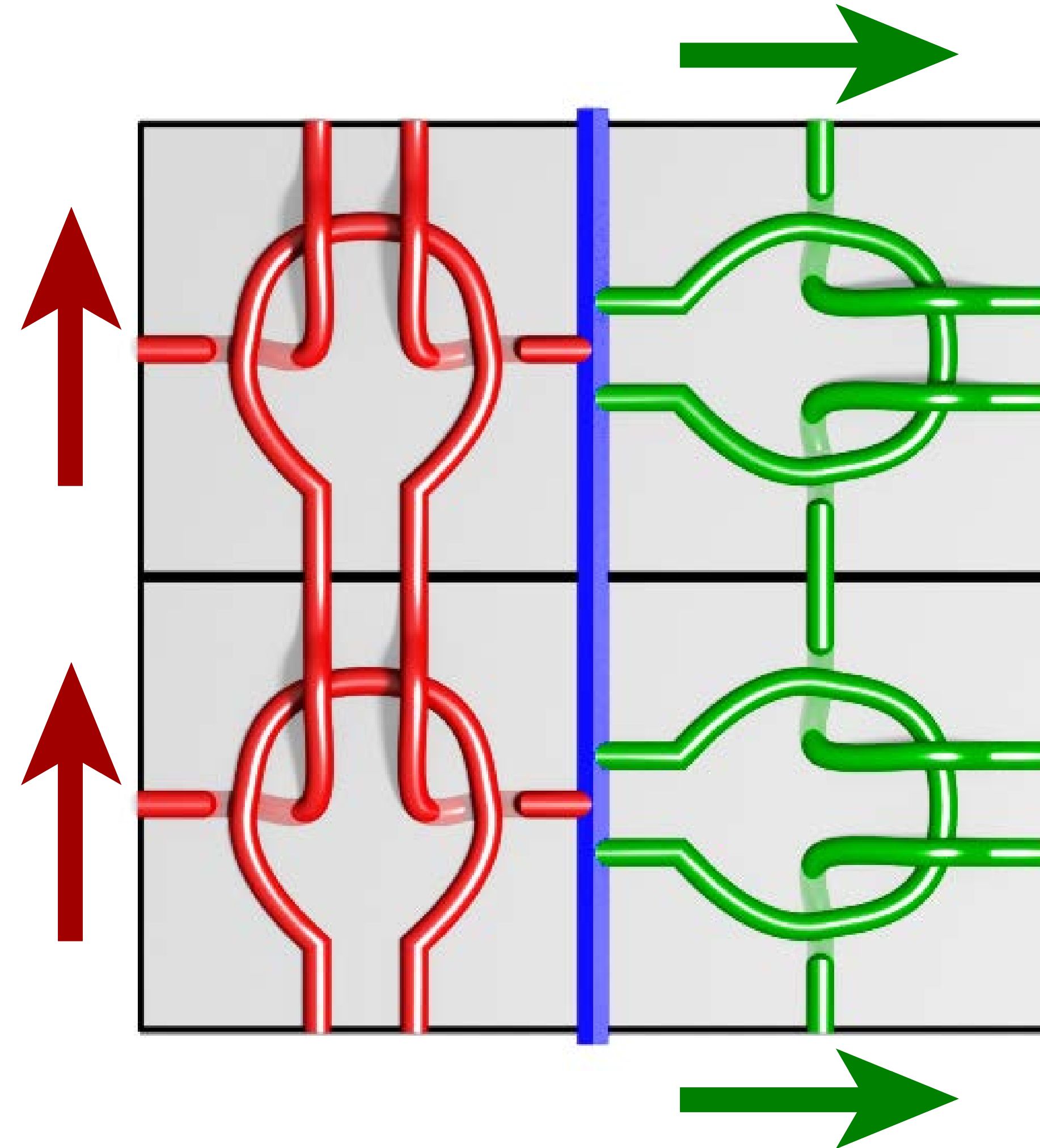

# Knittable Mismatched Directions

Expanding

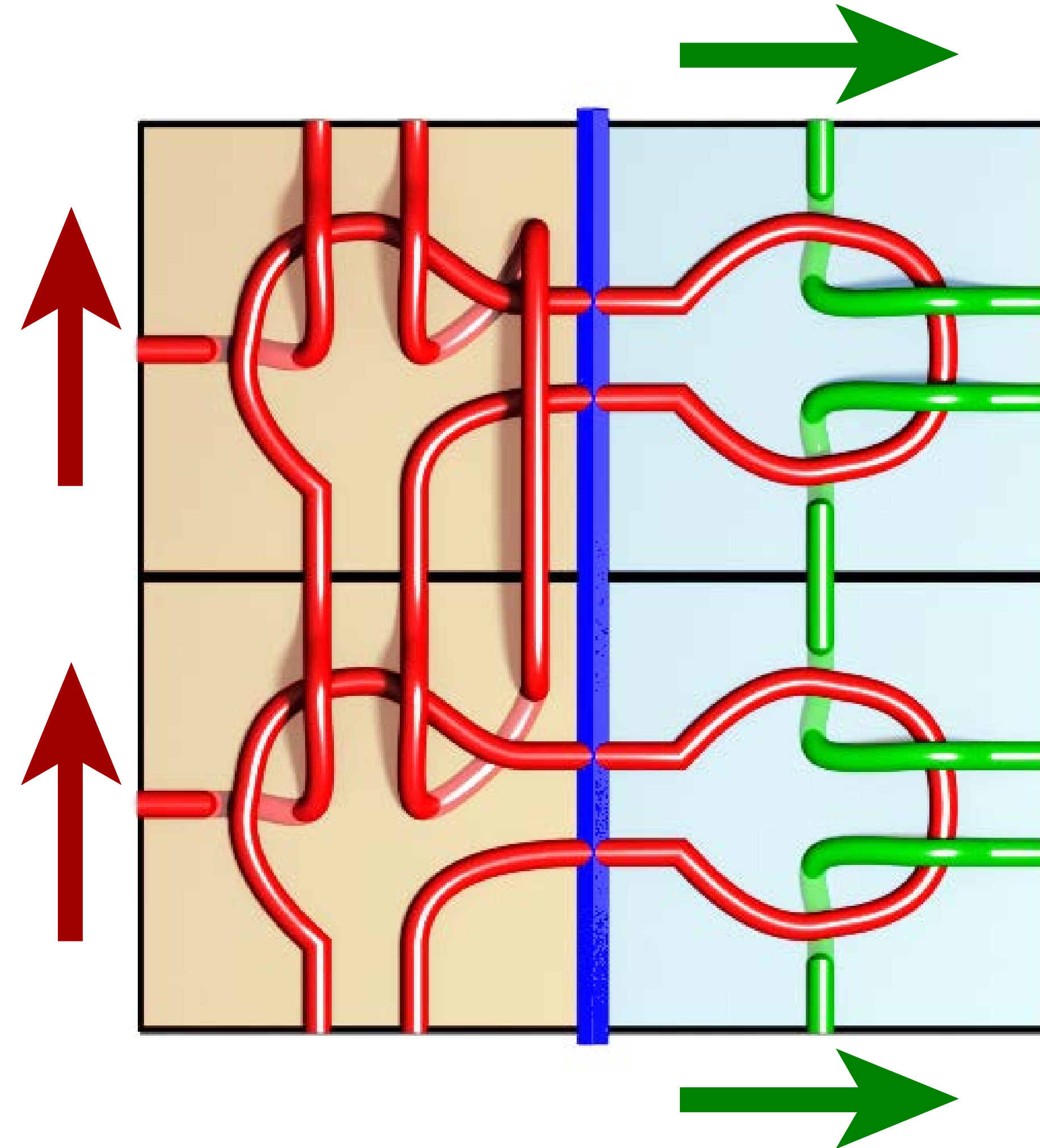



# Results

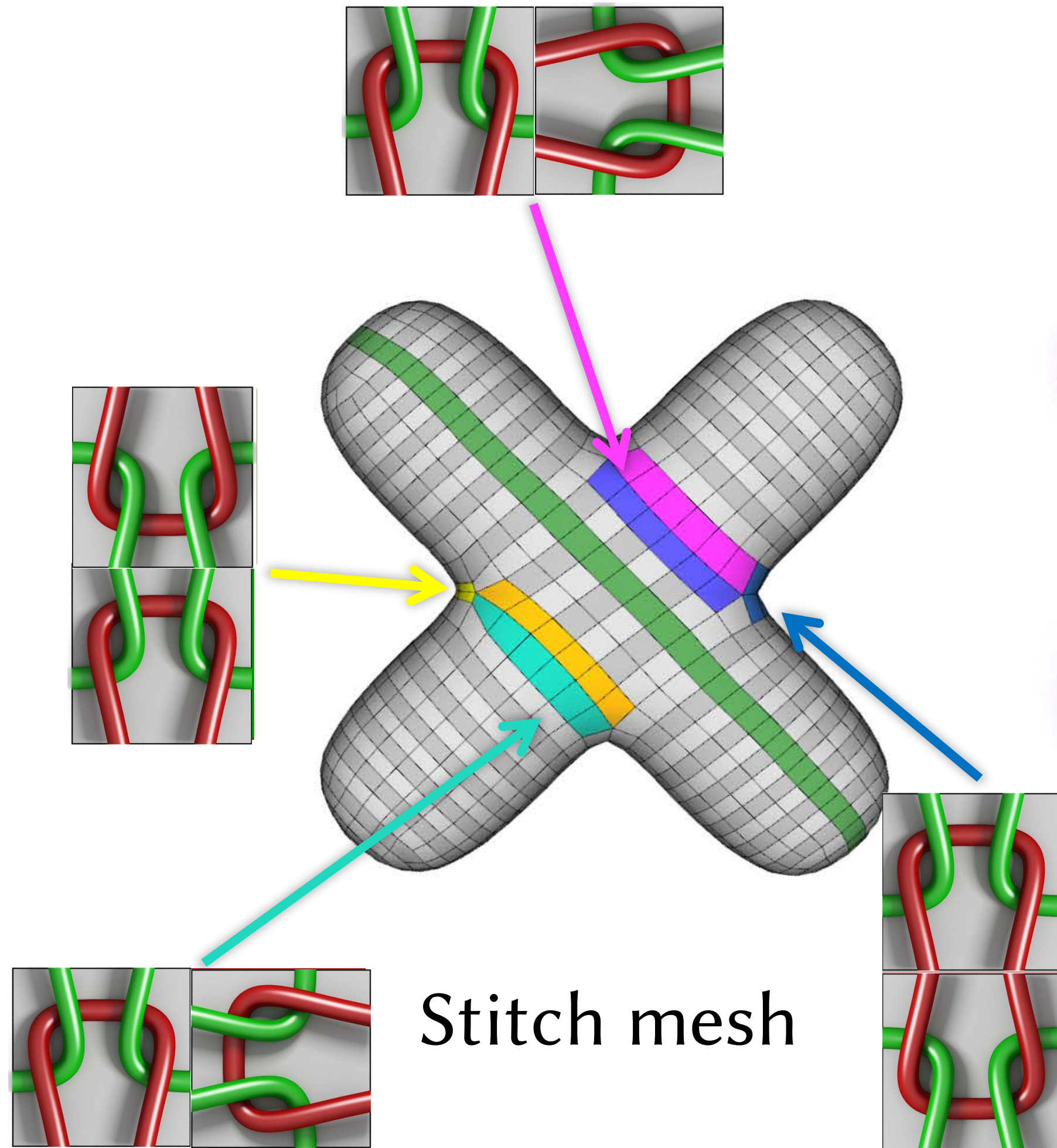

Stitch mesh

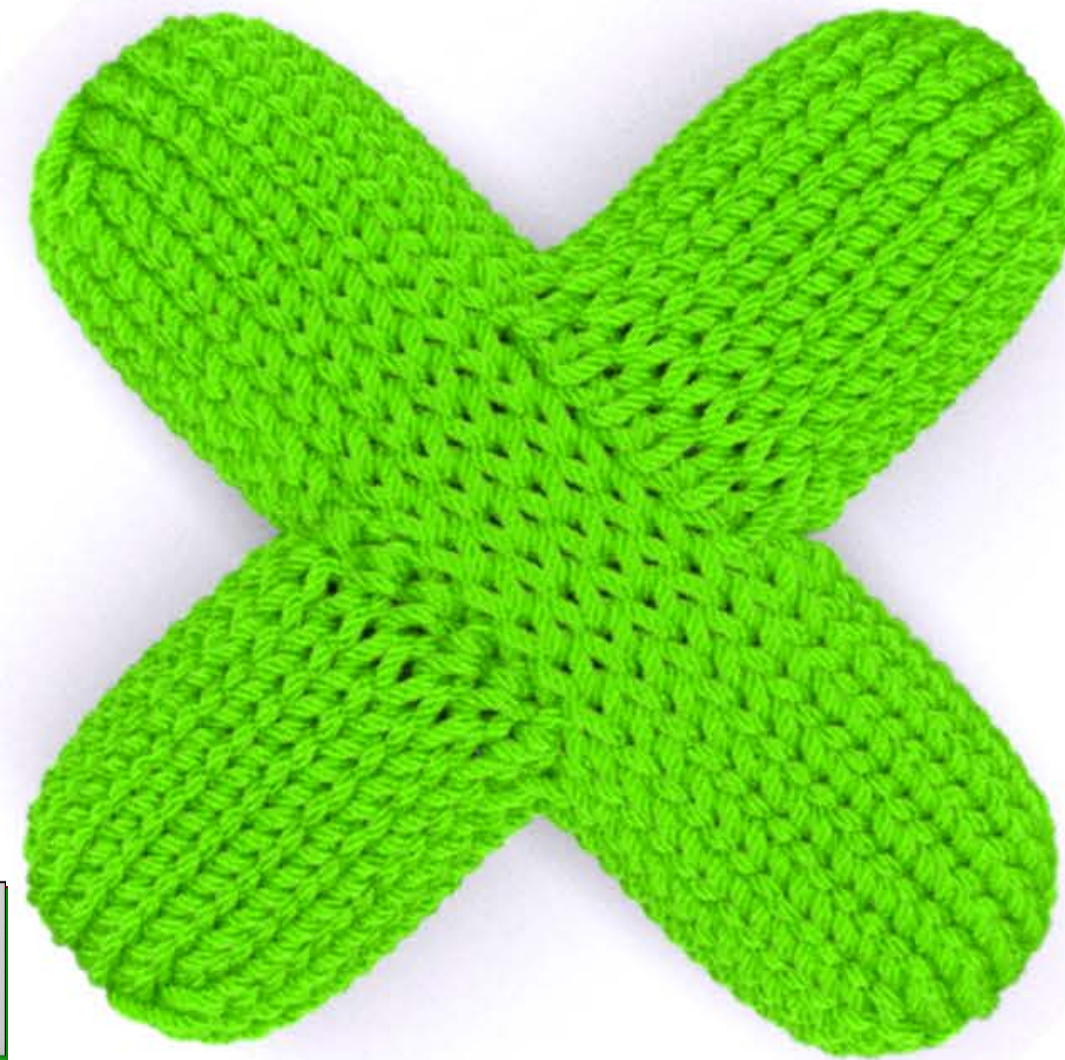

Simulated



Knitted

# Short-rows

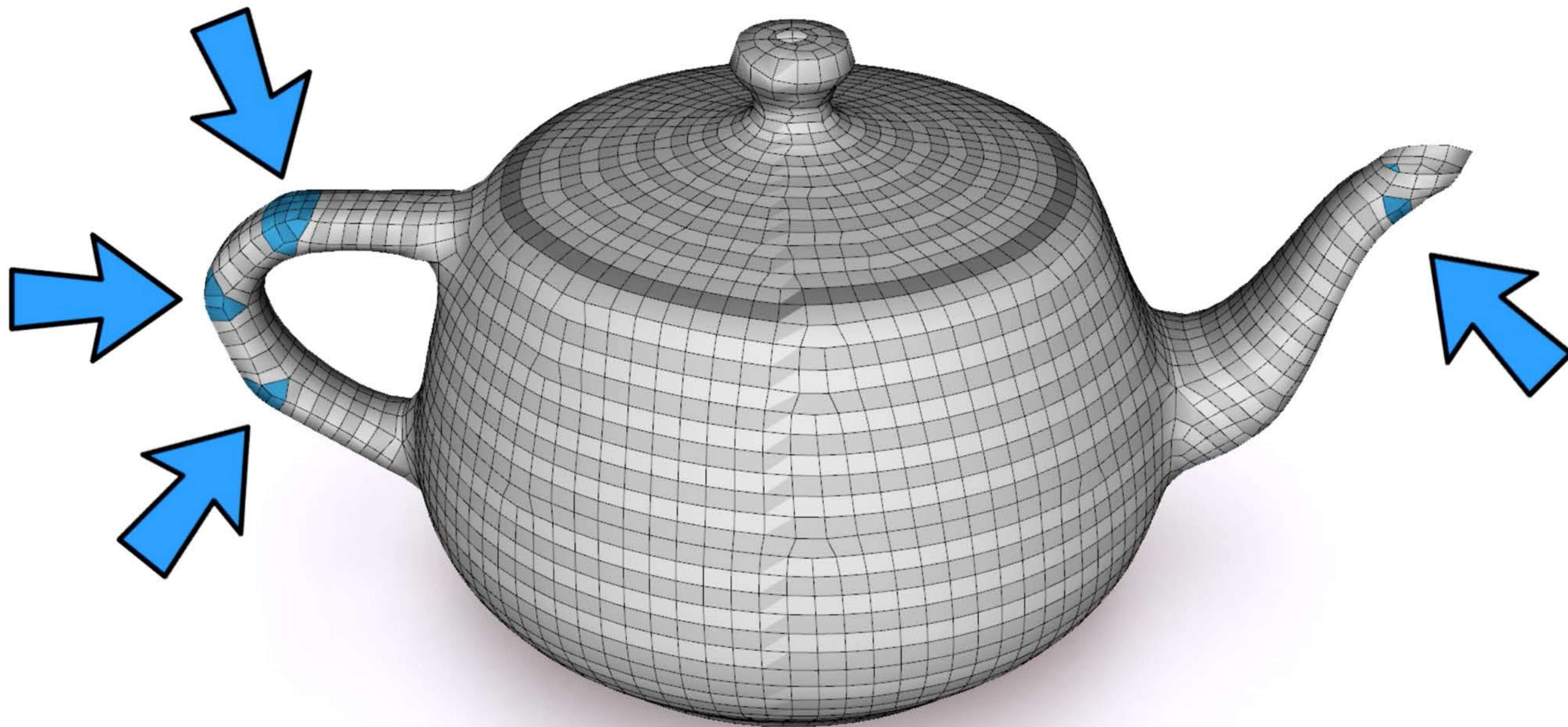

# Short-rows



# Short-rows



# Short-rows



# Short-rows

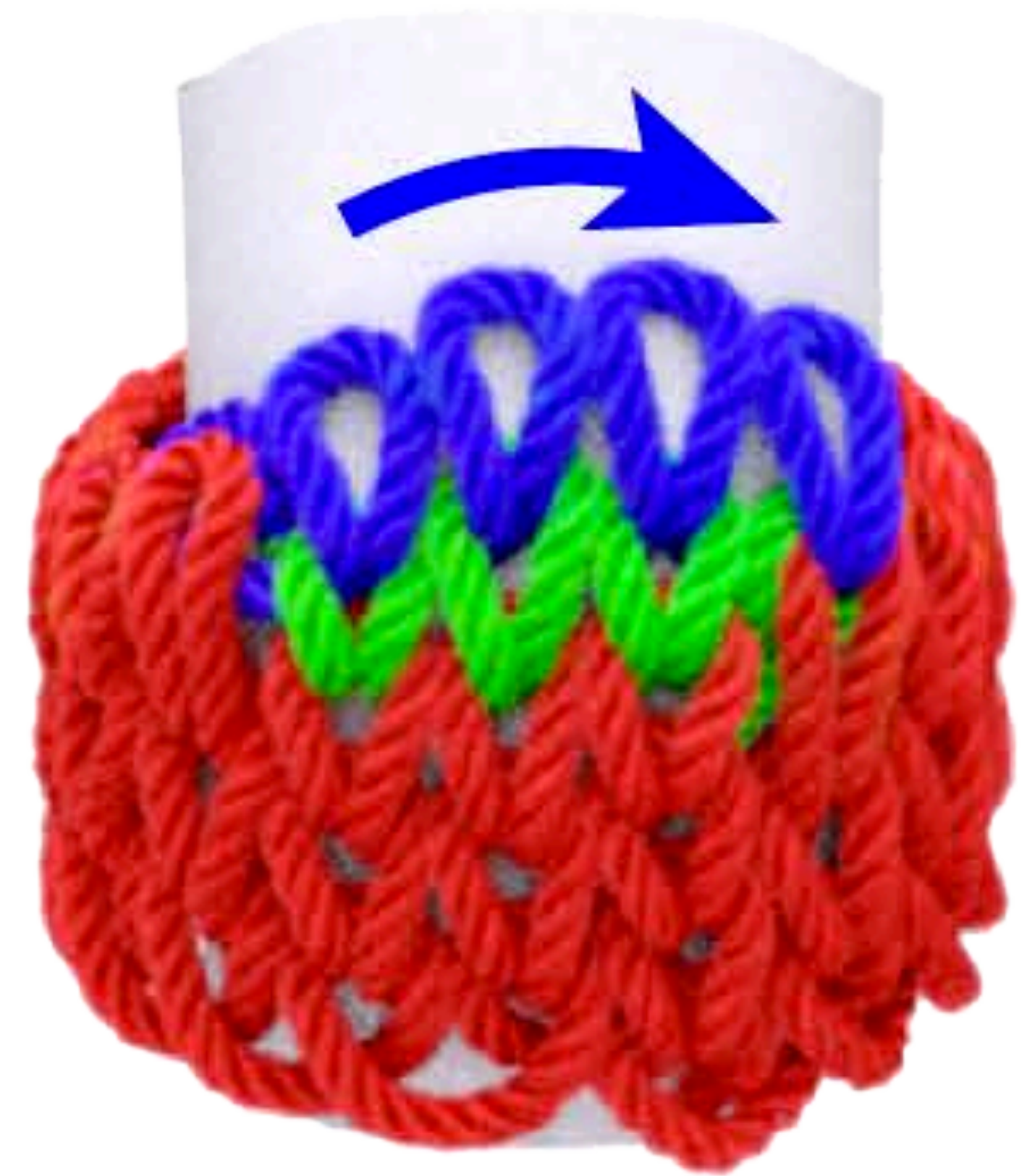

# Short-rows



# Short-rows

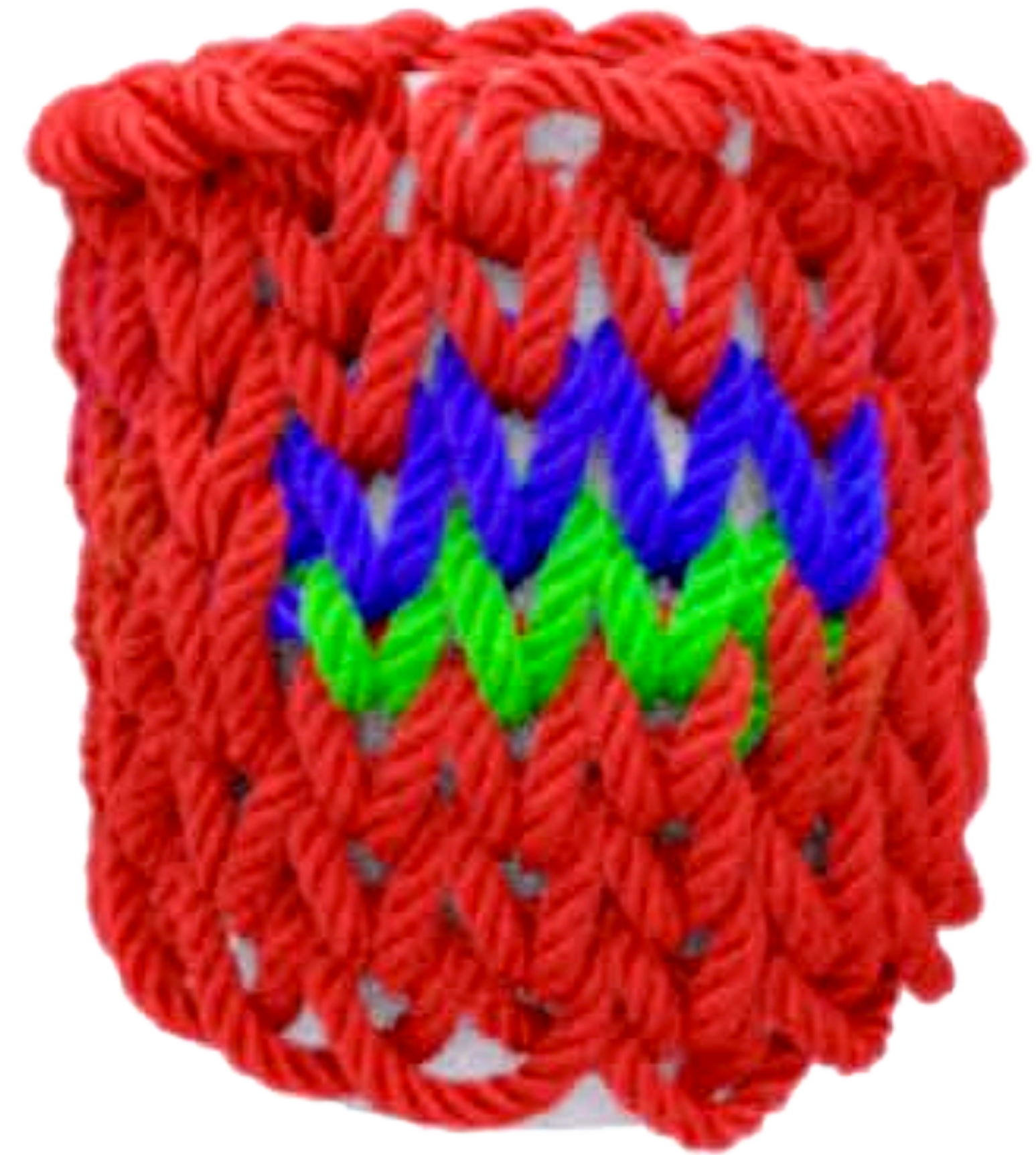



# Short-rows



Short-rows

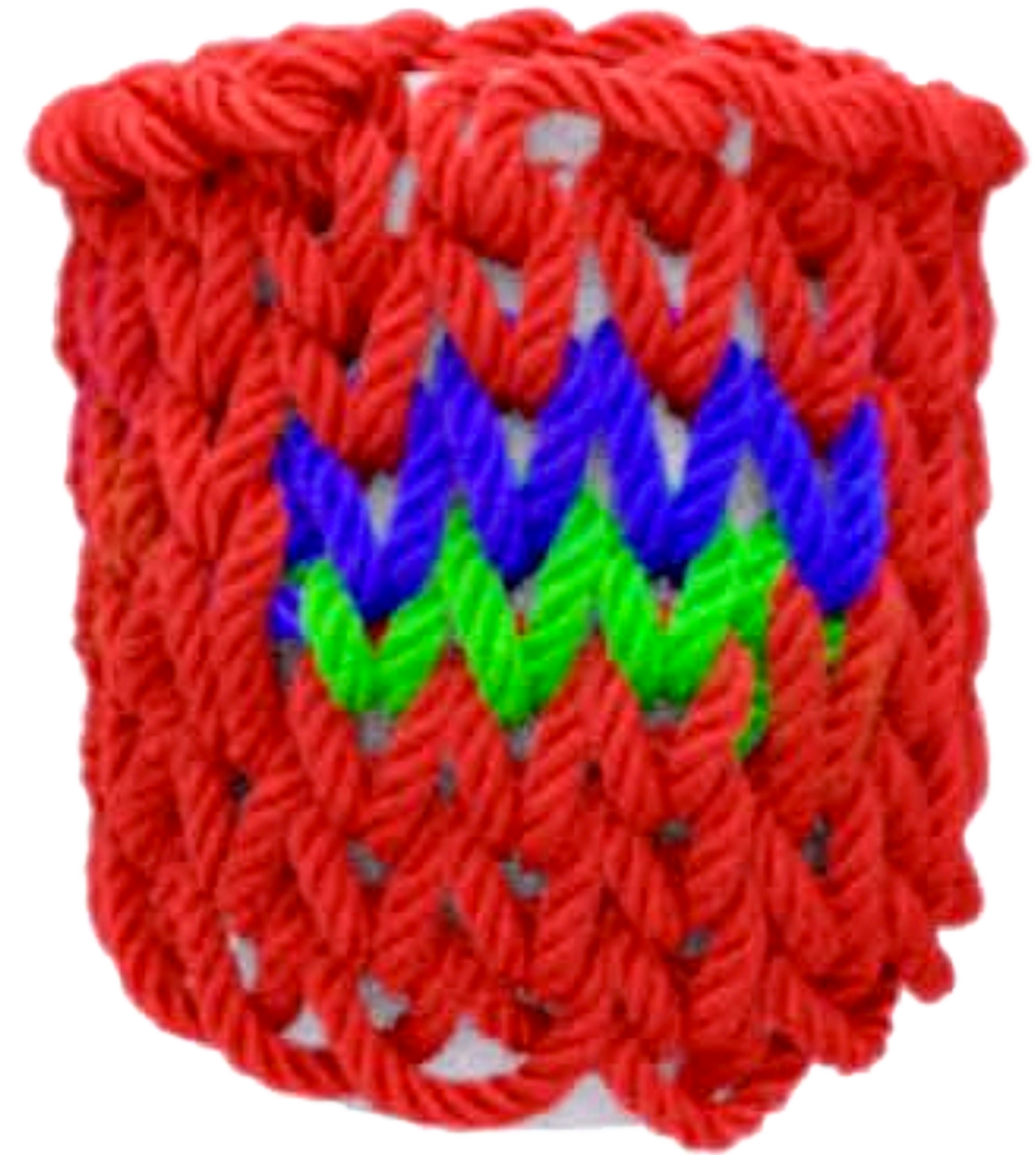

# Short-rows

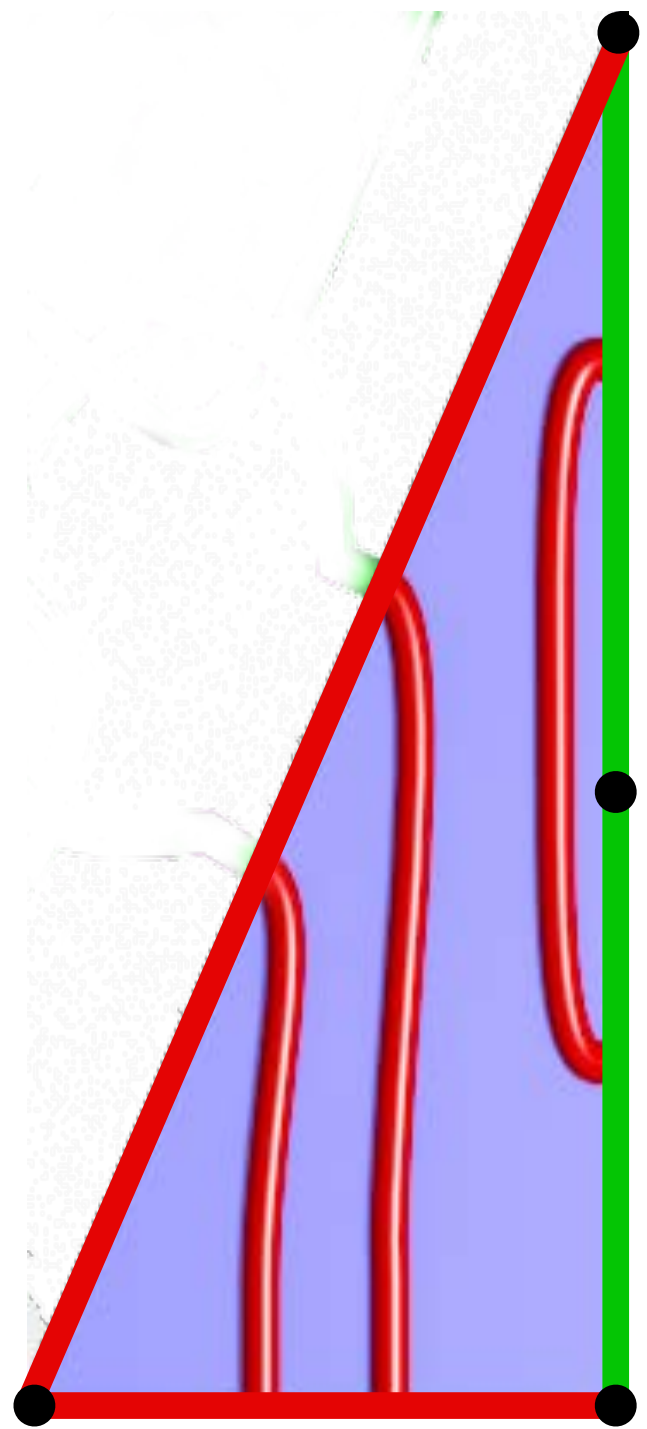

**Short-row face**

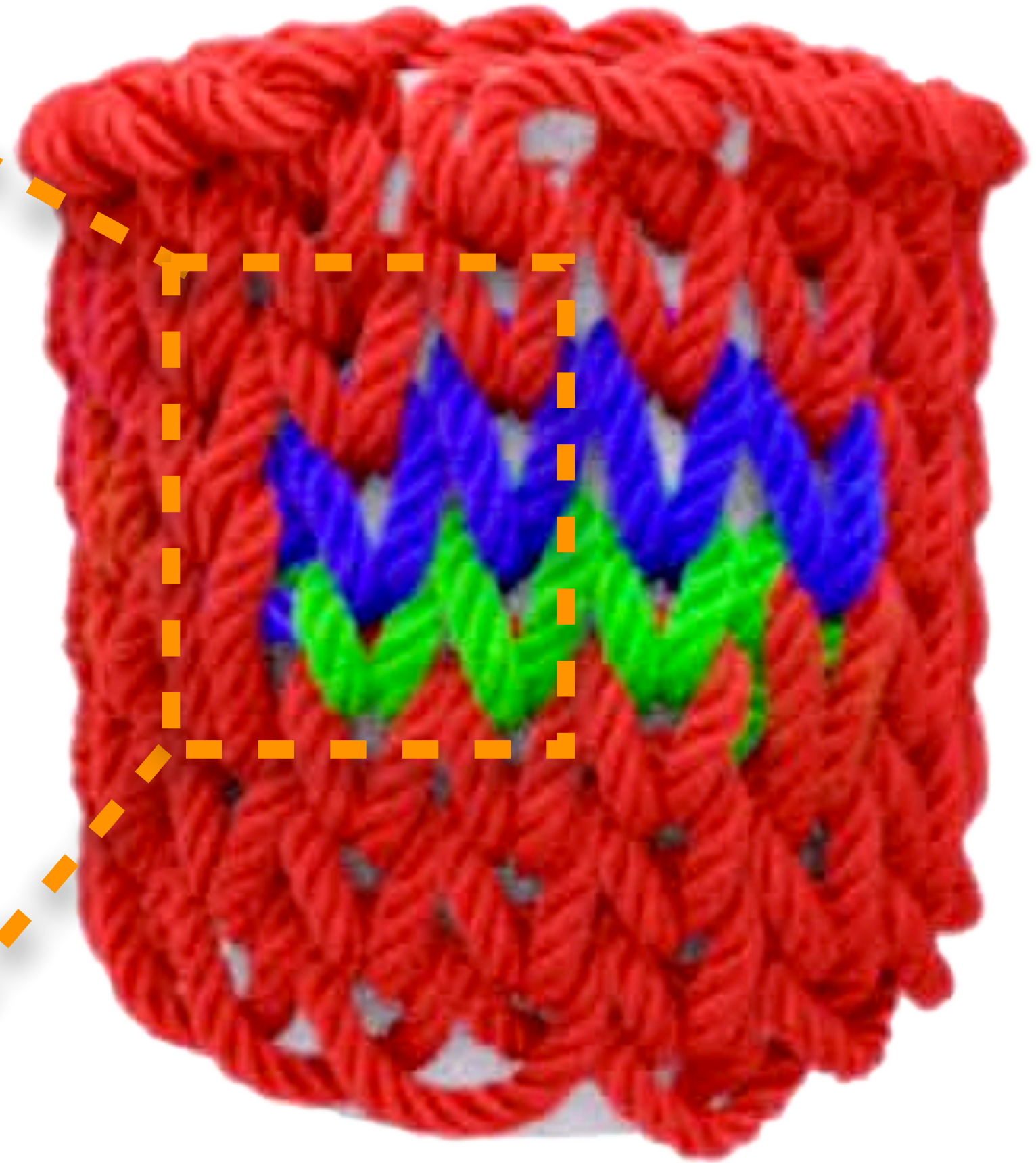
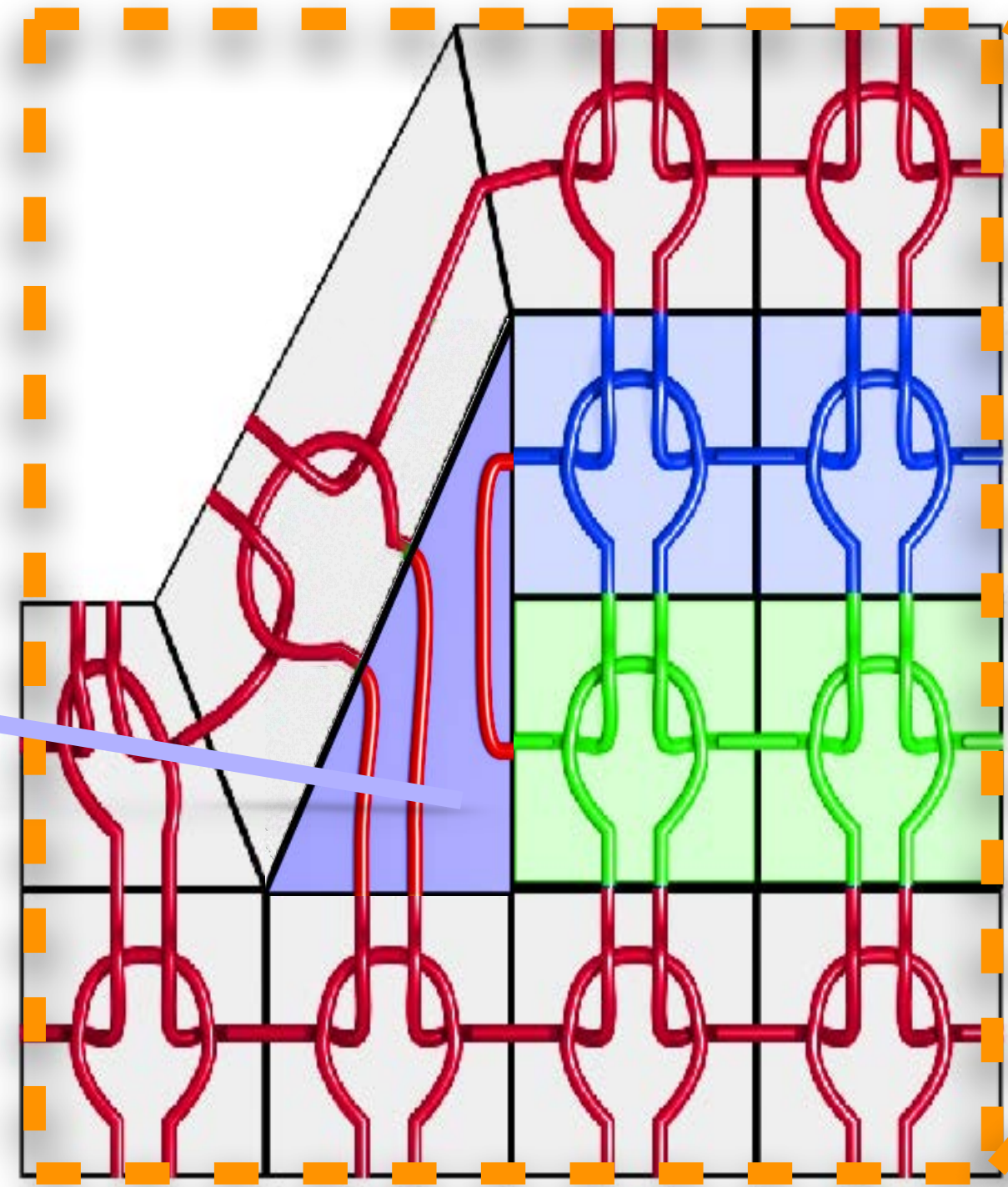

# Short-row + Mismatch

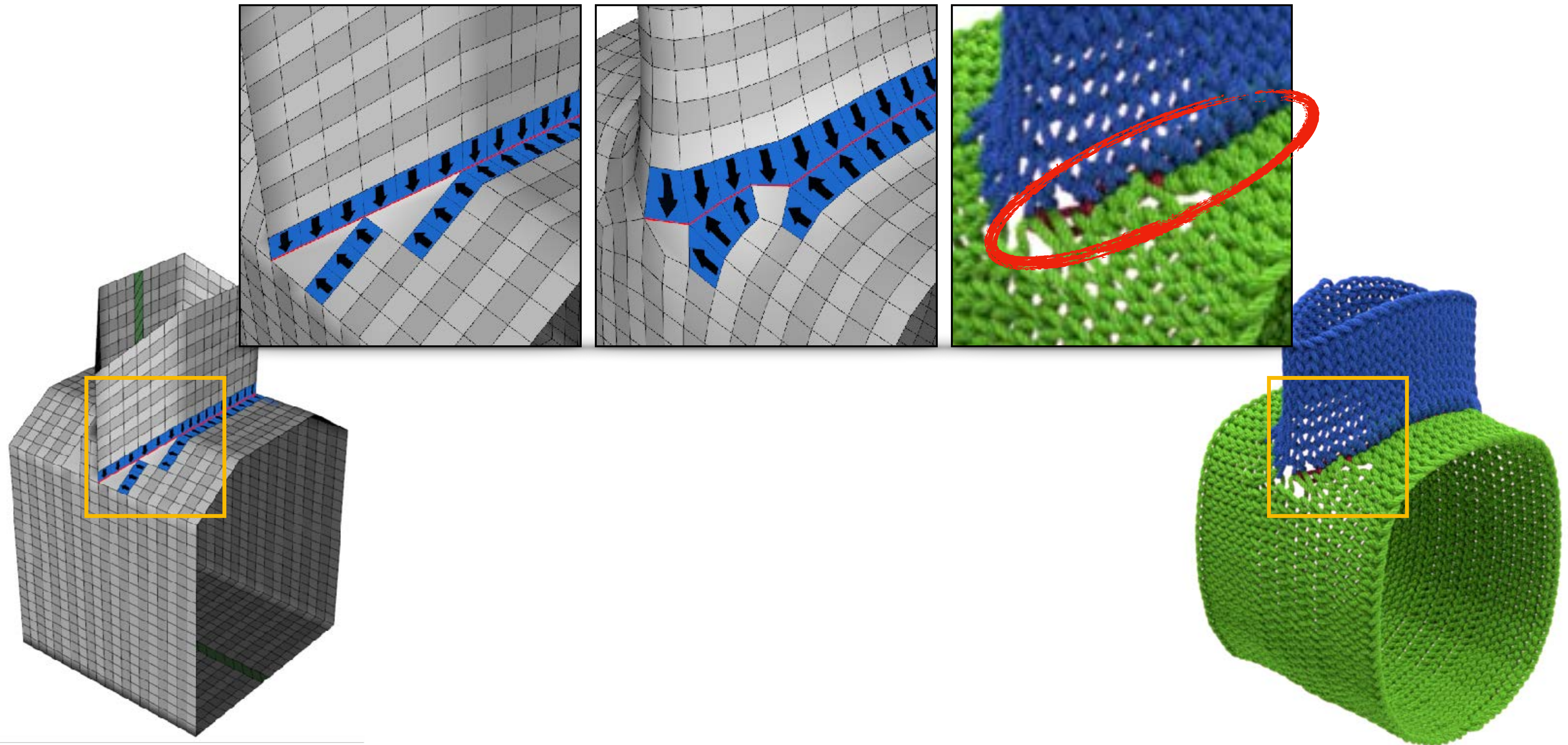

# Knittable Stitch Mesh

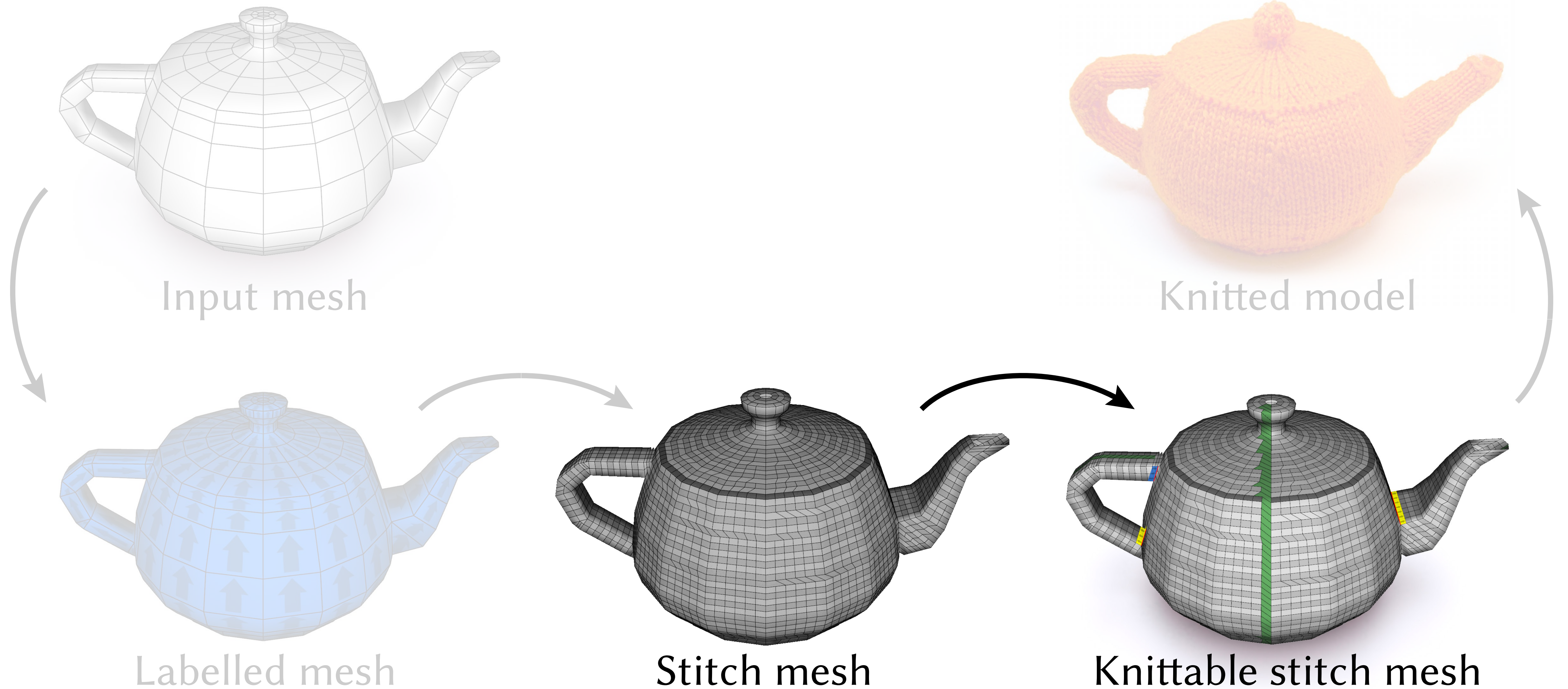

# Knitting Instructions Generation

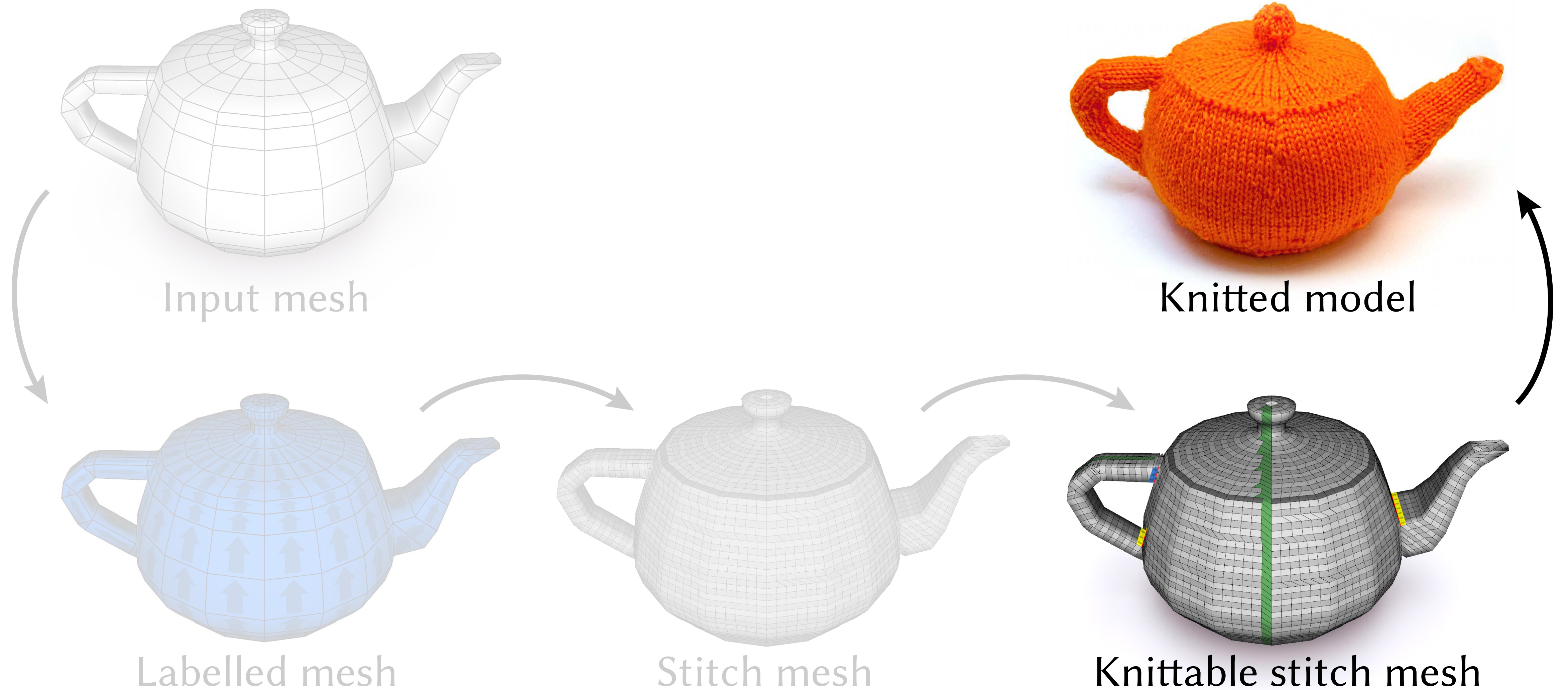

# Knitting Dependency

Regular

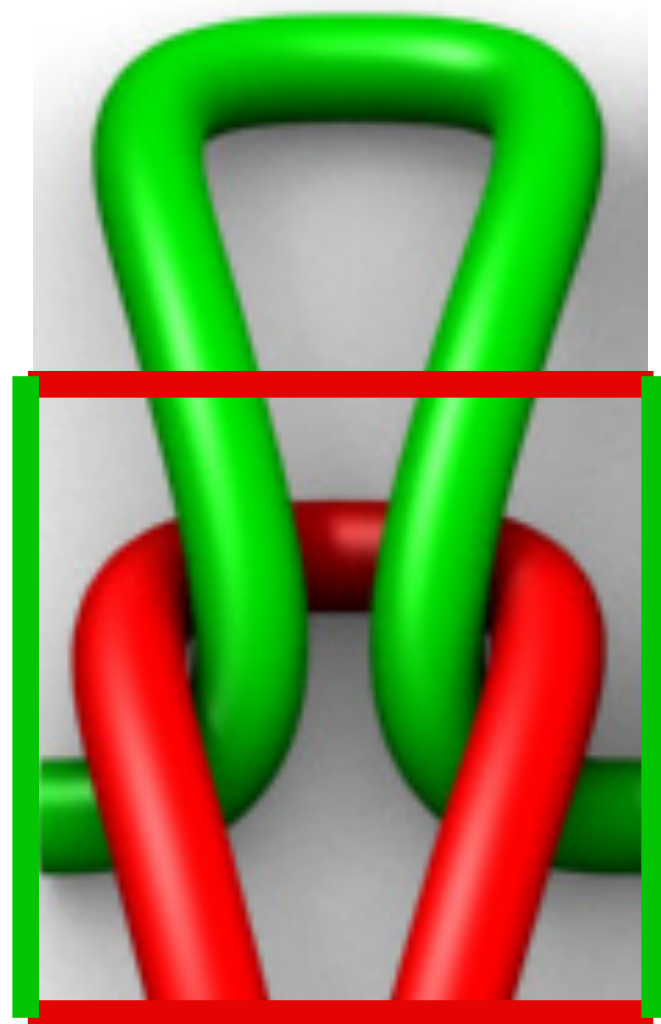

Decrease

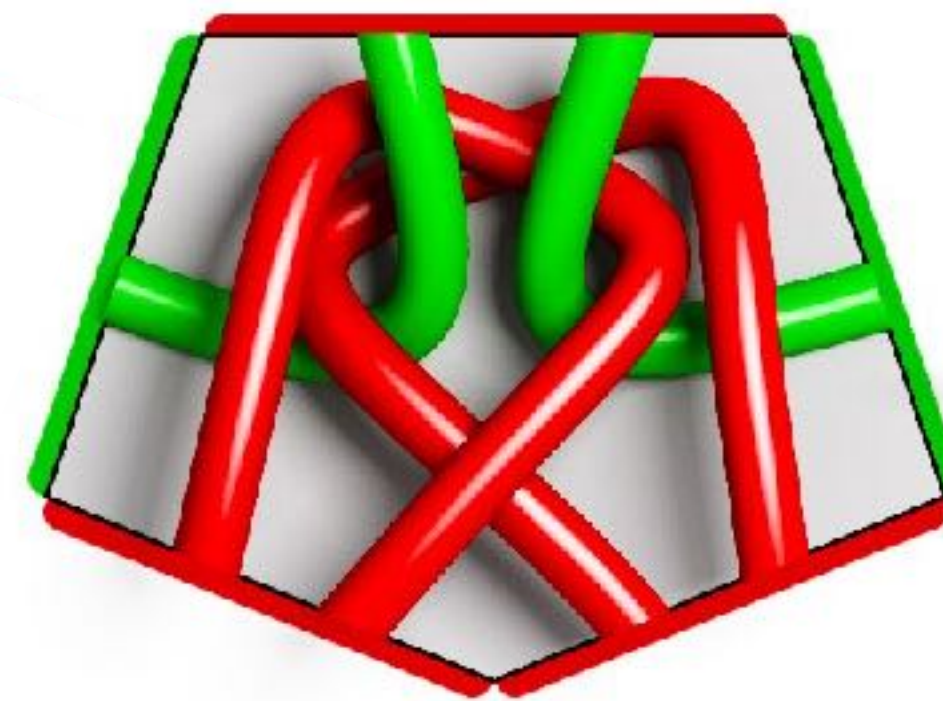

Short-row

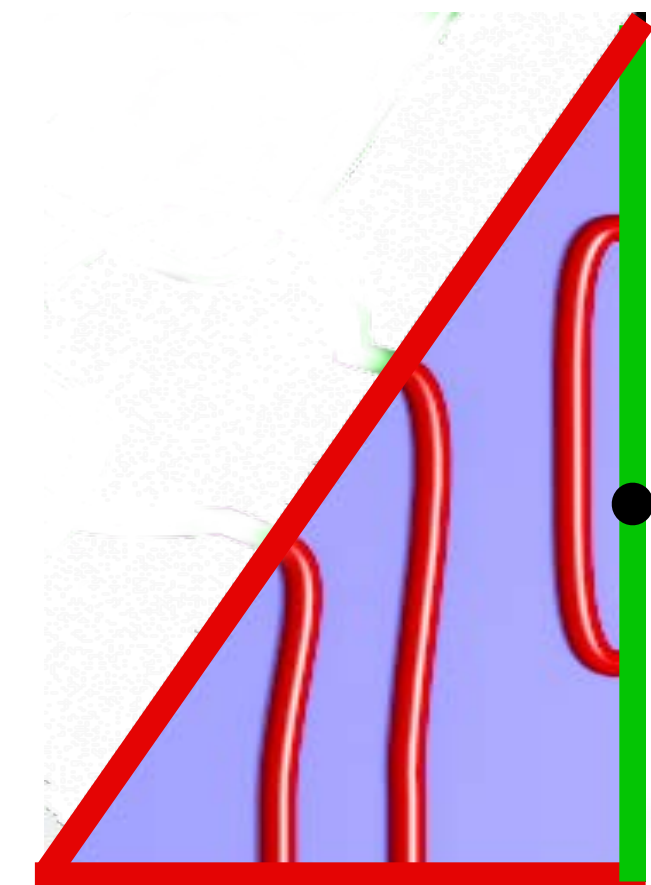

# Knitting Dependency

Contracting

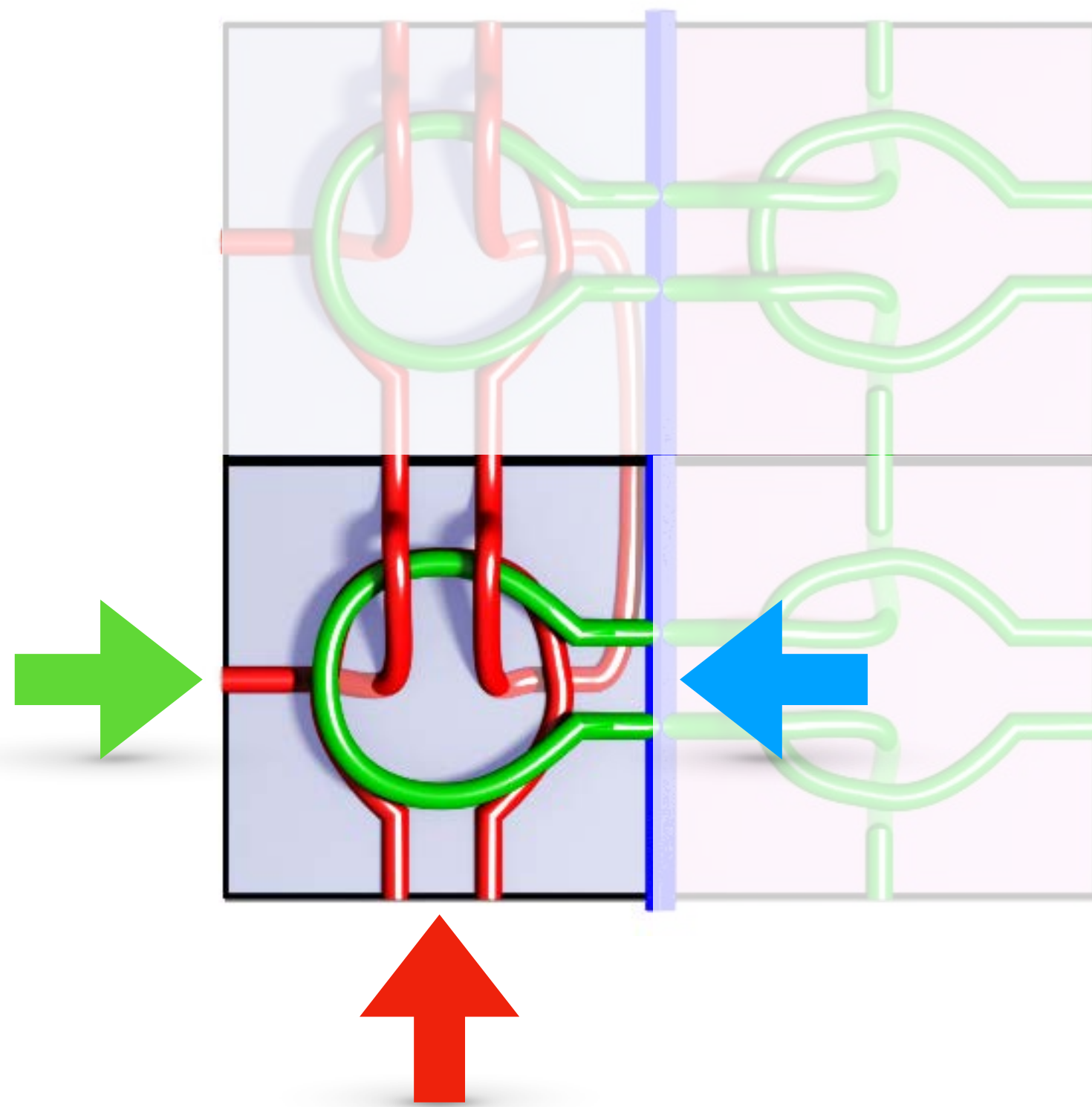

Joining

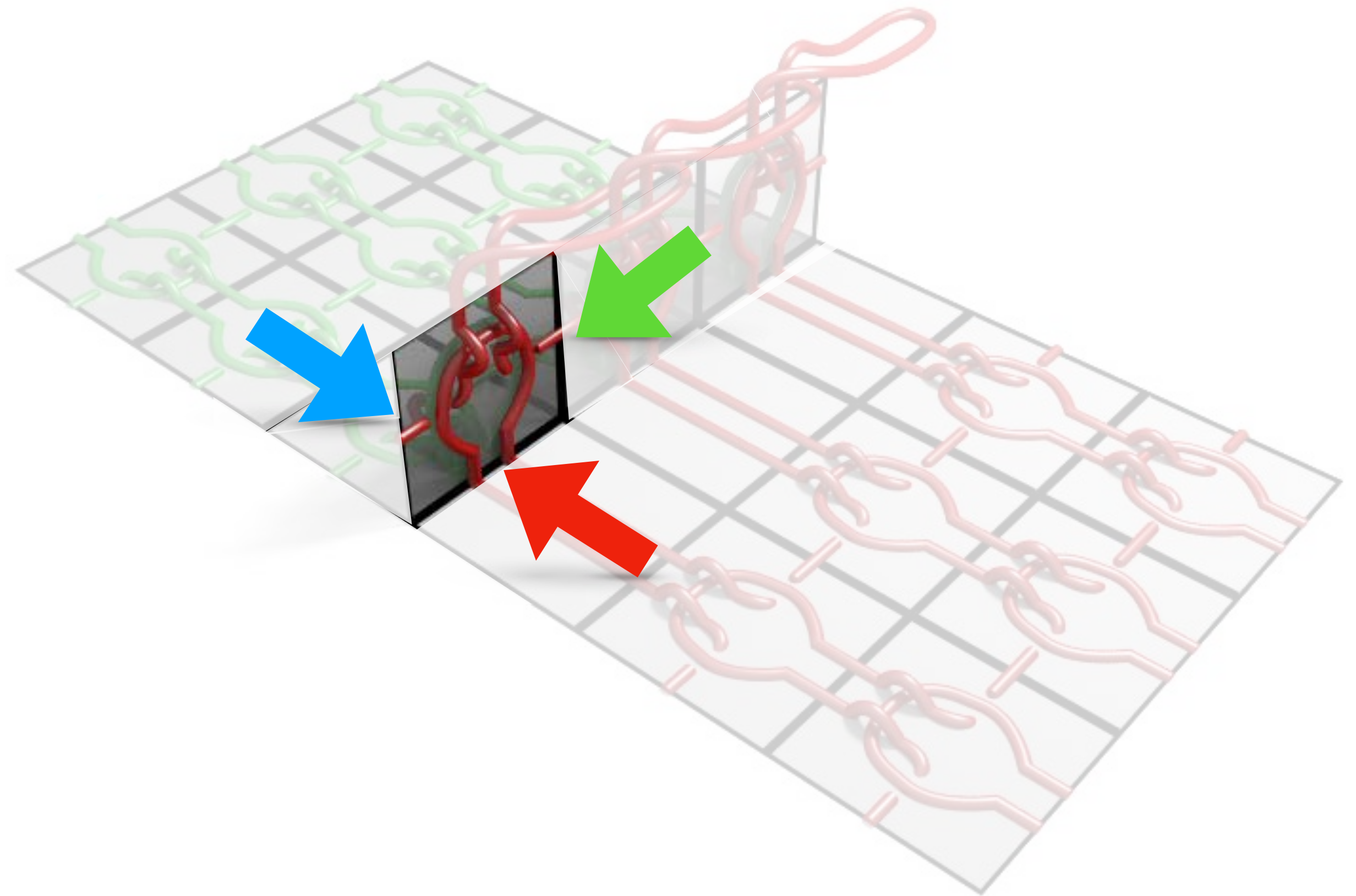

# Knitting Instruction Generation

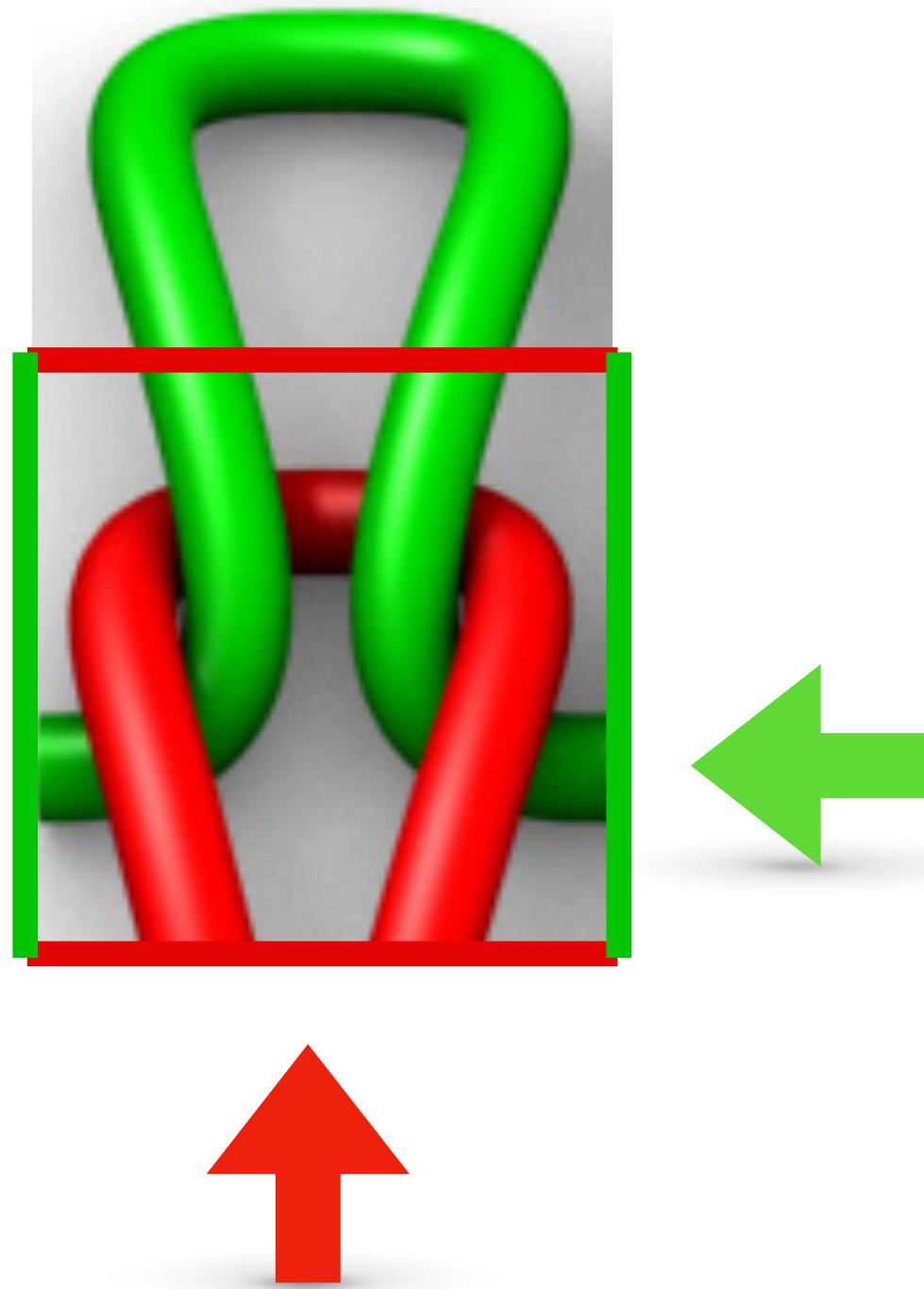

---

## ALGORITHM 1: Generate Knitting Instructions

---

$Q \leftarrow$  list of first stitches for each yarn piece

**while**  $Q$  is not empty **do**

$s \leftarrow$  the next ready stitch from  $Q$

**while** *true* **do**

        Generate knitting instructions for  $s$ .

        Mark  $s$  as knitted.

$s_c \leftarrow$  the next stitch after  $s$  along the course direction

**if**  $s_c$  exists **then**

$s \leftarrow s_c$

**else**

$s_w \leftarrow$  the stitch after  $s$  on the next row in wale direction

**if**  $s_w$  exists **and** yarn of  $s_w =$  yarn of  $s$  **then**

$s \leftarrow s_c$

**else**

                Terminate the yarn piece

**break**

**if**  $s$  is not ready **then**

        Enqueue  $s$  into  $Q$ .

**break**

---



# Hand Knitting Interface

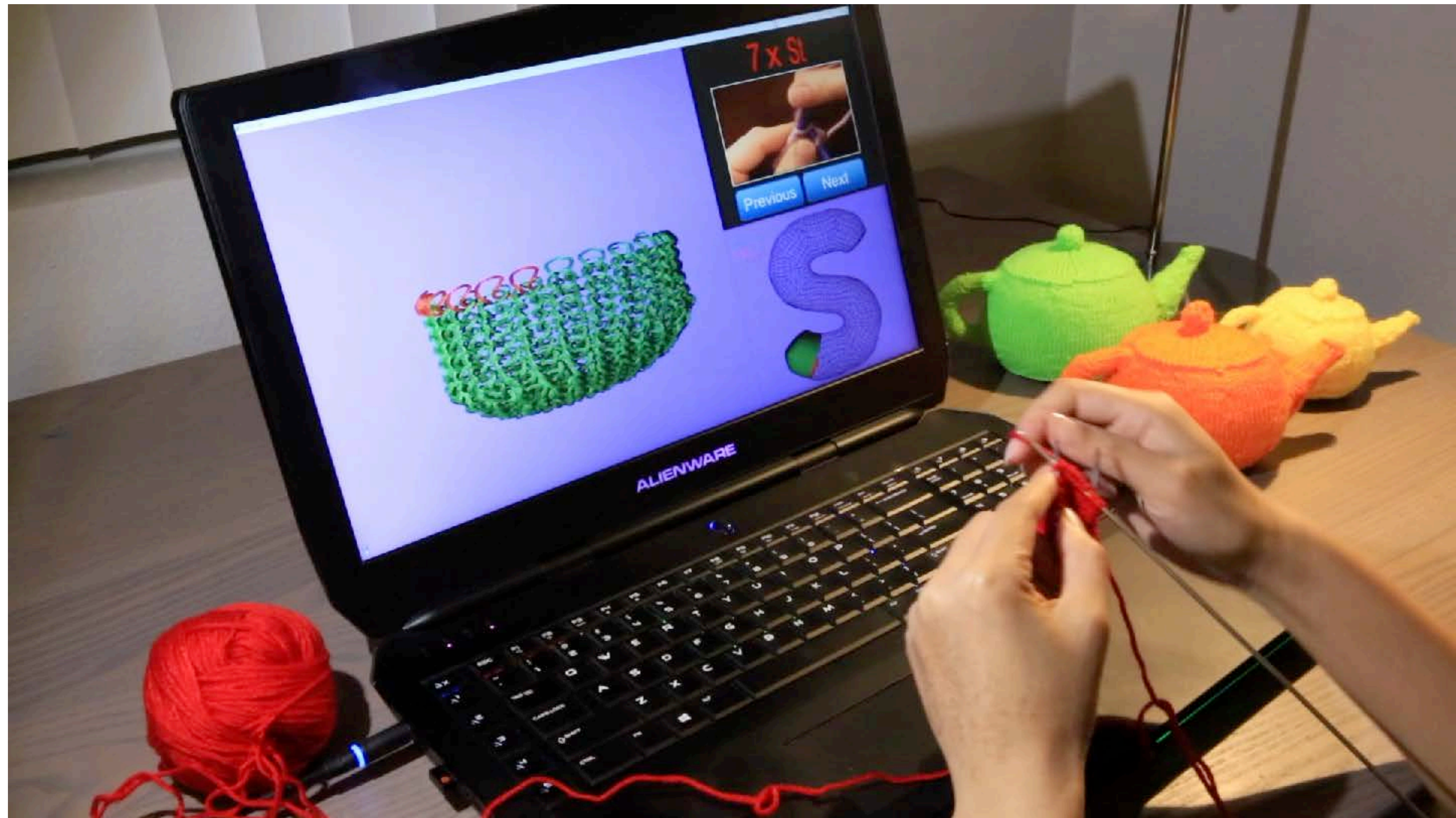

# Results

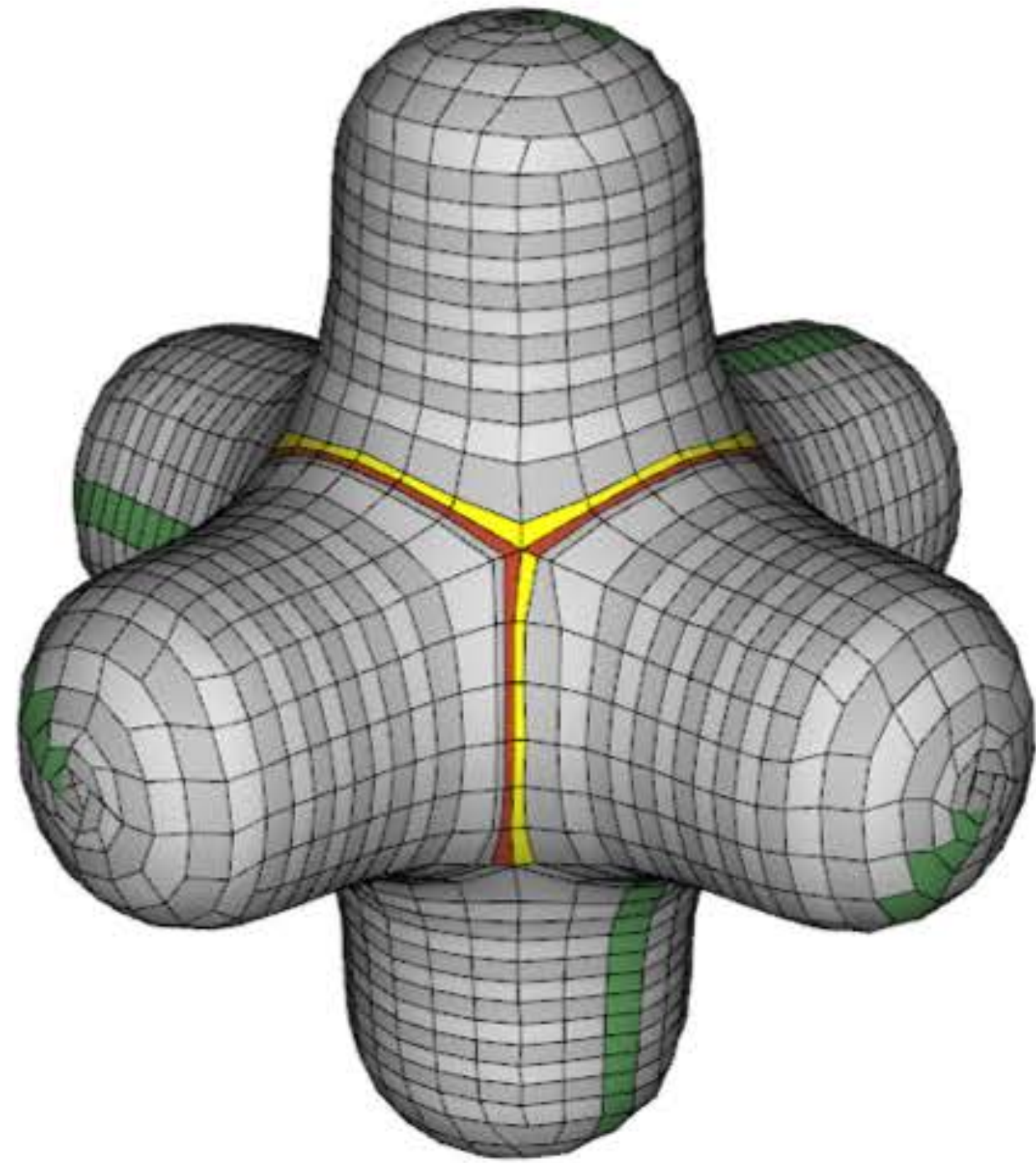

Stitch mesh



Simulated



Knitted

# Results

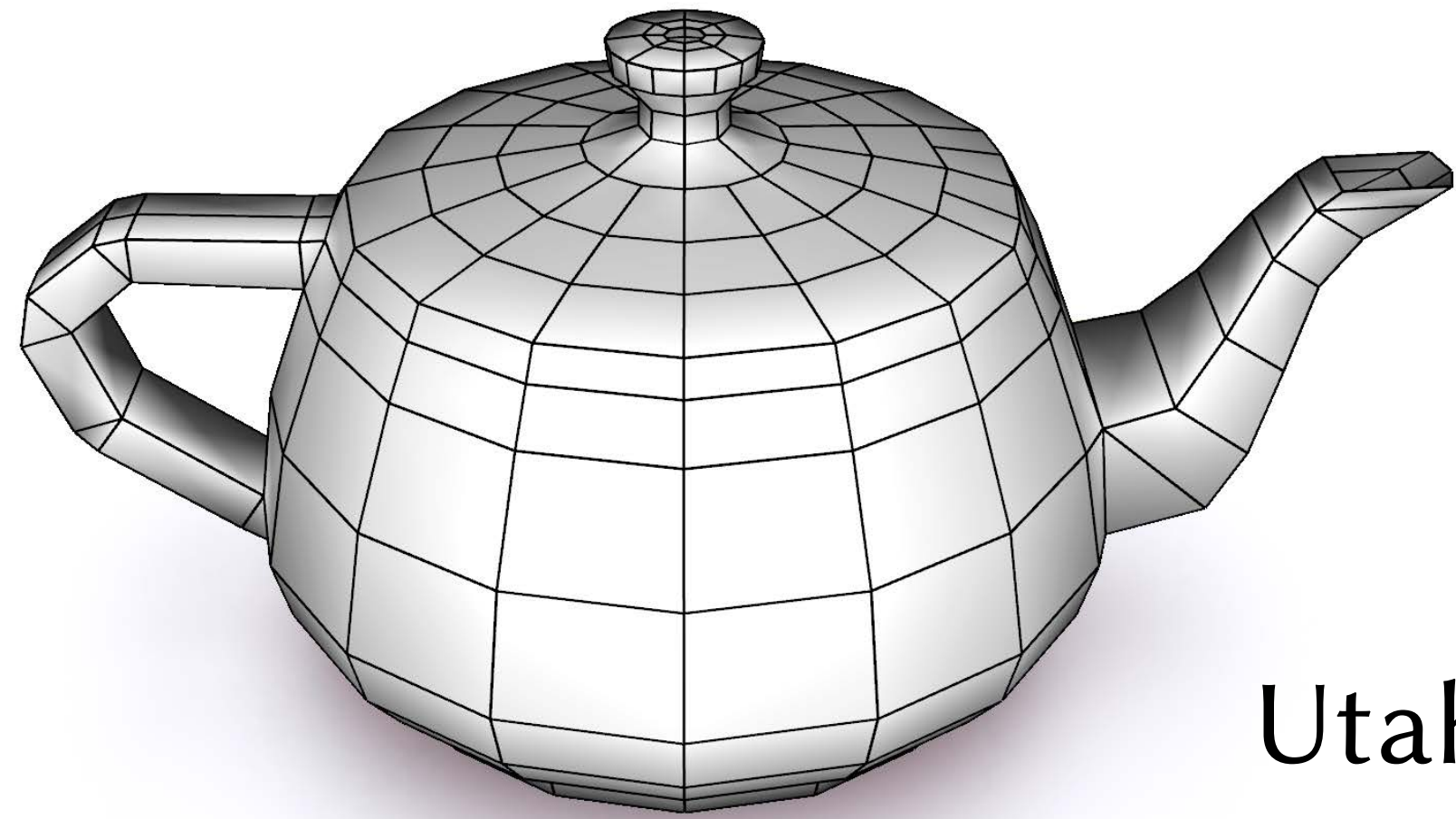

Utah Teapot





# Results



# Results

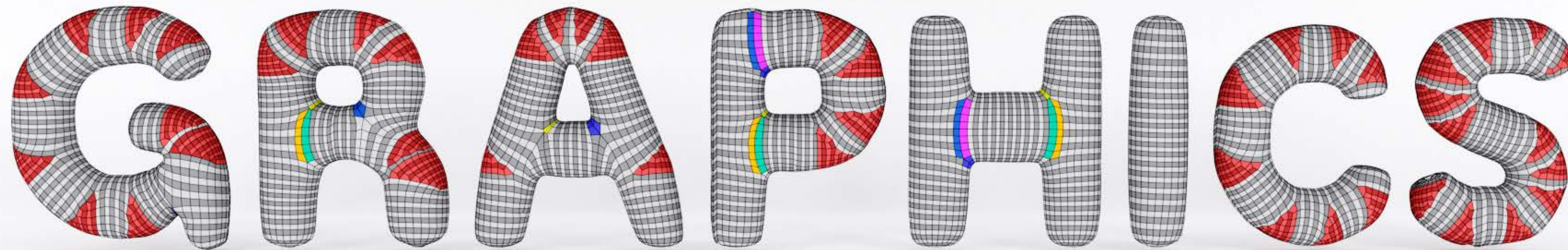

Stitch mesh

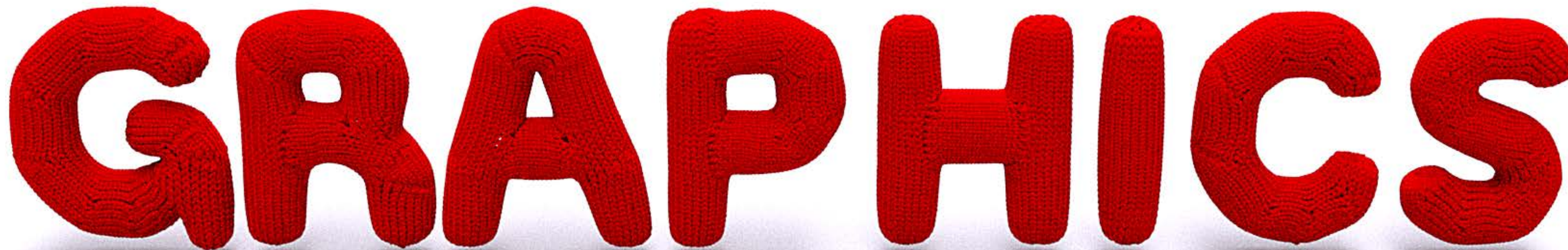

Simulated



Knitted

# Results



Stitch mesh



Simulated



Knitted

# Results

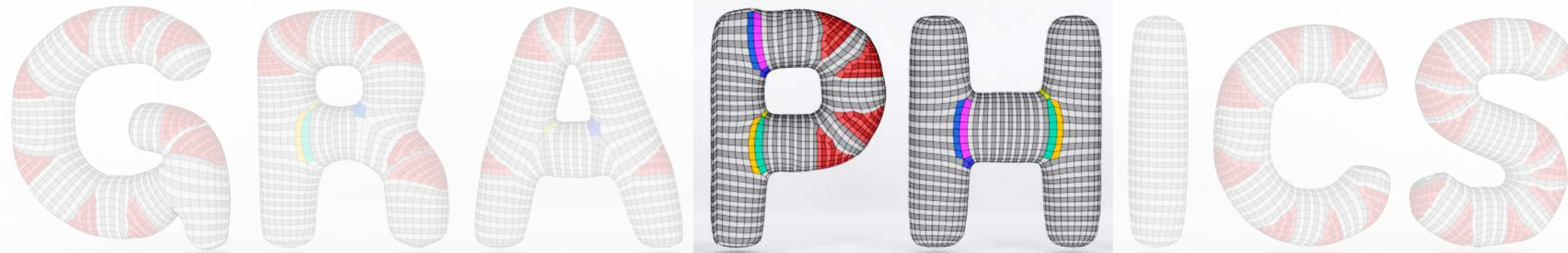

Stitch mesh

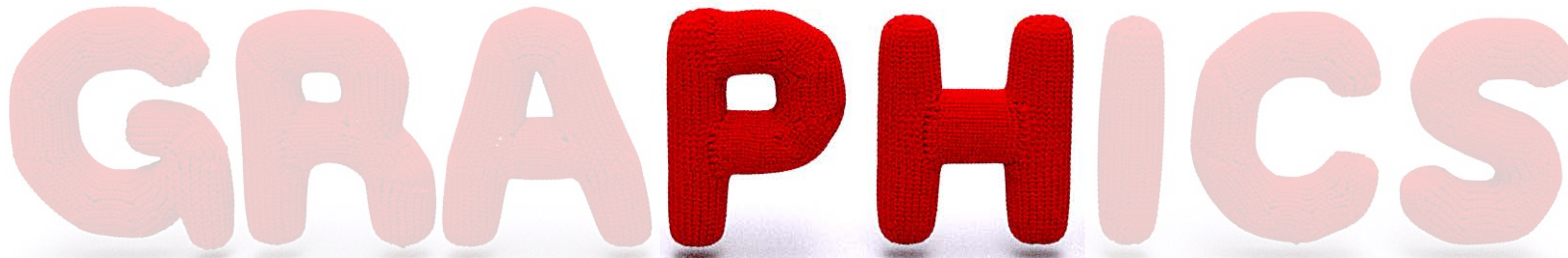

Simulated



Knitted



# Results

GRAAPHICS

GRAAPHICS

# Results



# Conclusion

- Knittable stitch mesh framework

# Conclusion

- Knittable stitch mesh framework
- Shift-paths

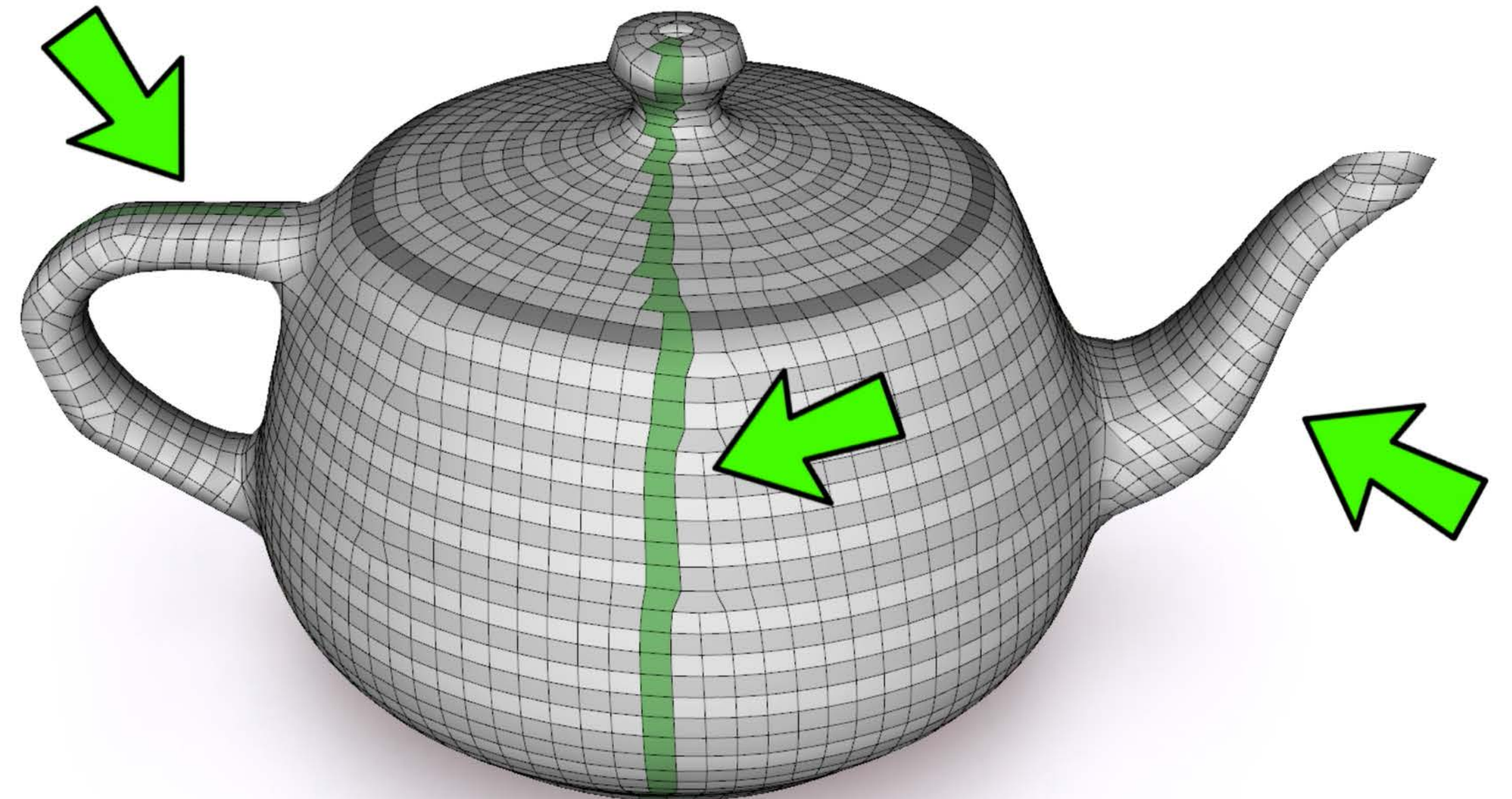

# Conclusion

- Knittable stitch mesh framework
  - Shift-paths
  - Knittable mismatched directions

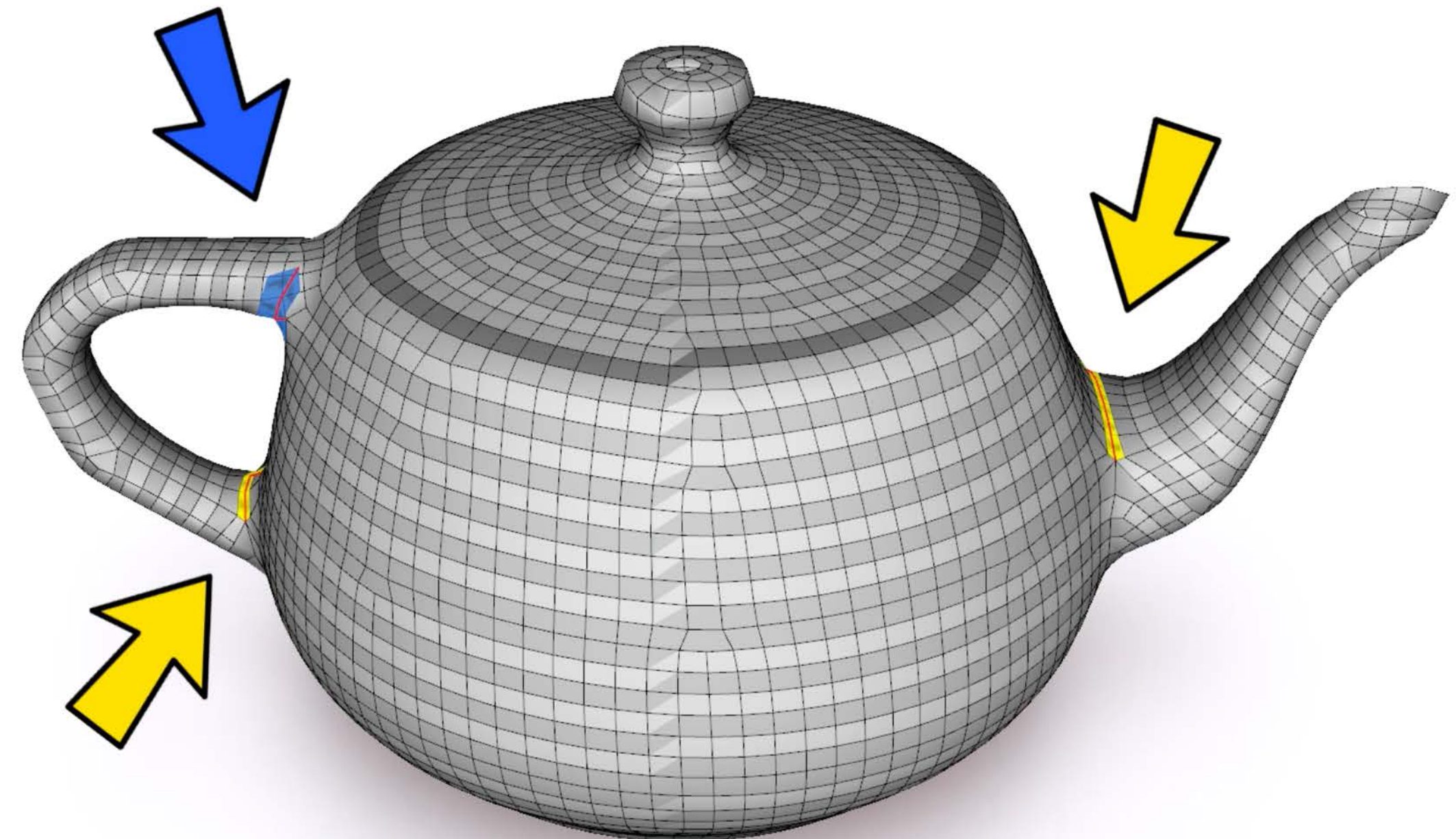

# Conclusion

- Knittable stitch mesh framework
  - Shift-paths
  - Knittable mismatched directions
  - Short-rows

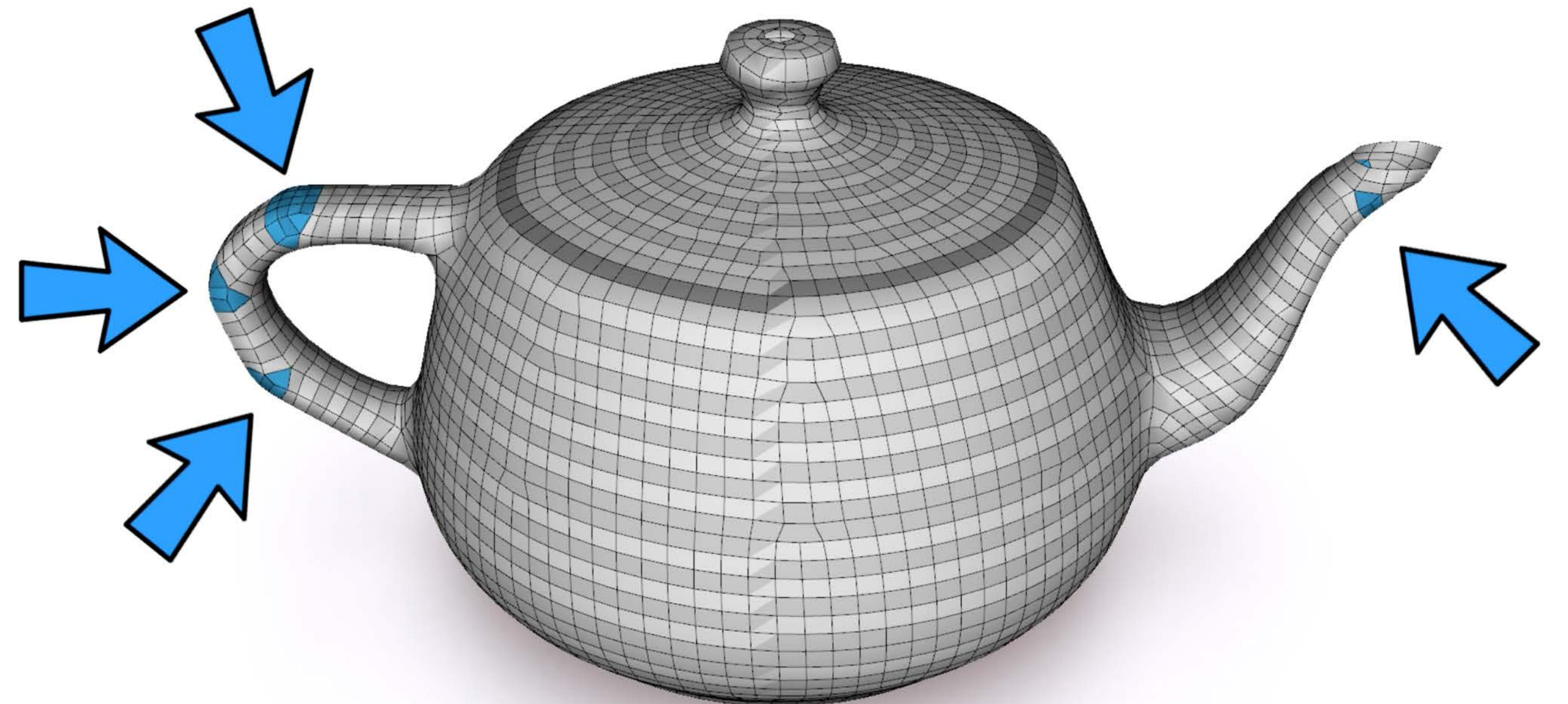

# Conclusion

- Knittable stitch mesh framework
  - Shift-paths
  - Knittable mismatched directions
  - Short-rows
- Knitting instruction generation algorithm

# Stitch Mesh Modeling Pipeline

- Automatic stitch meshing

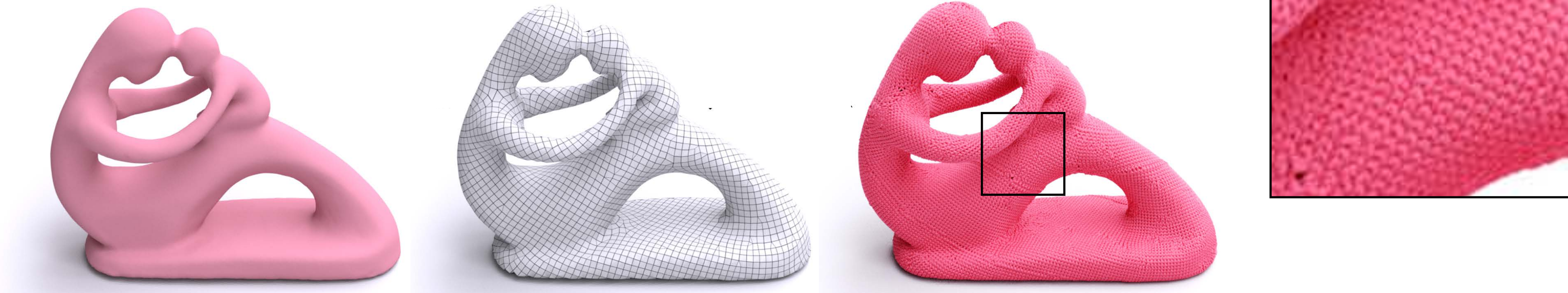

## Stitch Meshing

Kui Wu, Xifeng Gao, Zachary Ferguson, Daniele Panozzo, Cem Yuksel  
Siggraph 2018



# Stitch Mesh Modeling Pipeline

- Automatic stitch meshing

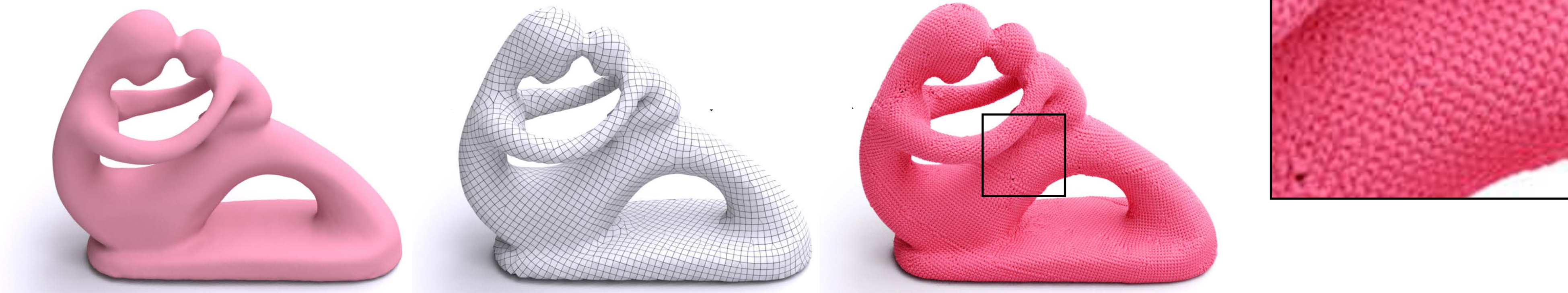

- Machine knittable stitch mesh (next talk!)

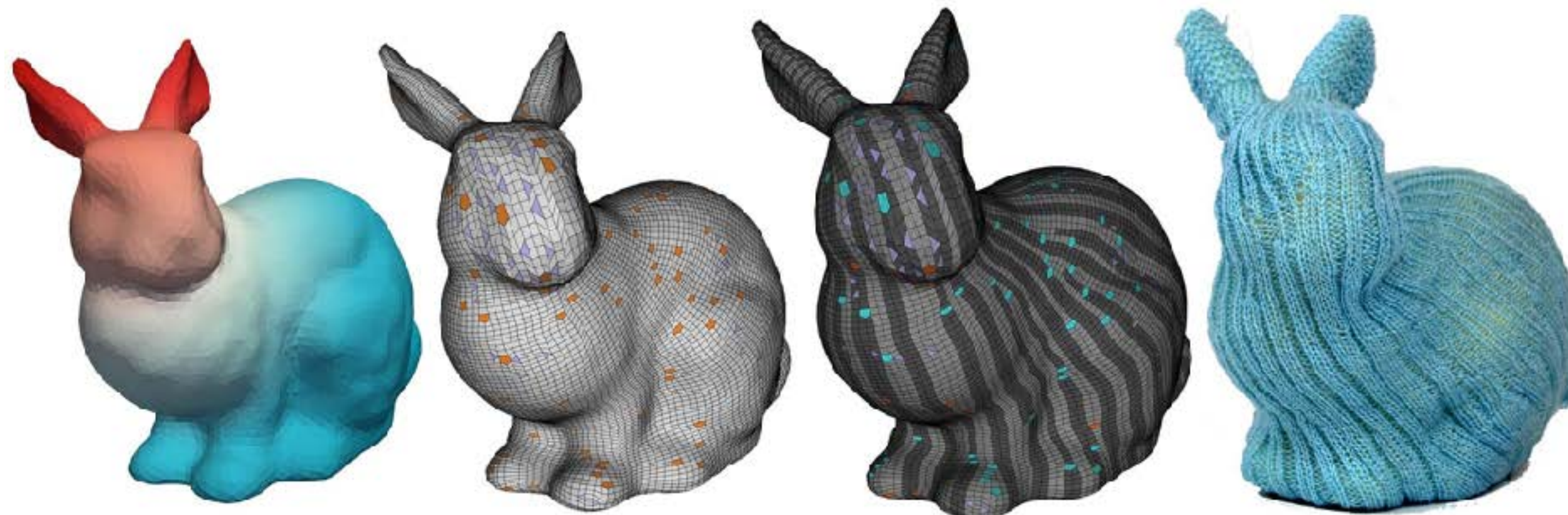

Visual Knitting Machine Programming

Vidya Narayanan\*

Kui Wu\*

Cem Yuksel

Jim McCann

\* joint first authors

# Visual Knitting Machine Programming

Vidya Narayanan\*, Kui Wu\*,  
Cem Yuksel, and James McCann



\* joint first authors



# Visual Knitting Machine Programming

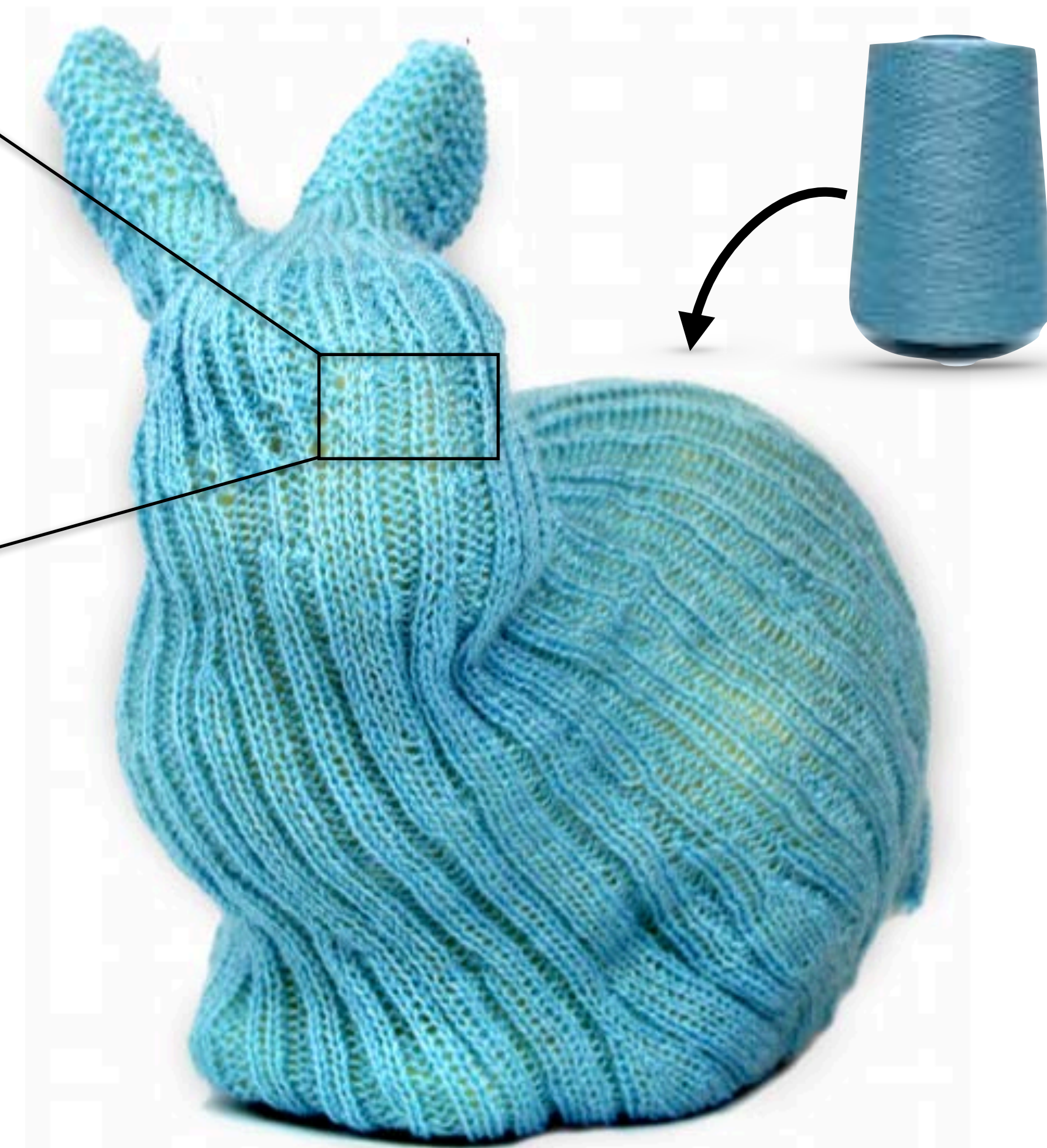
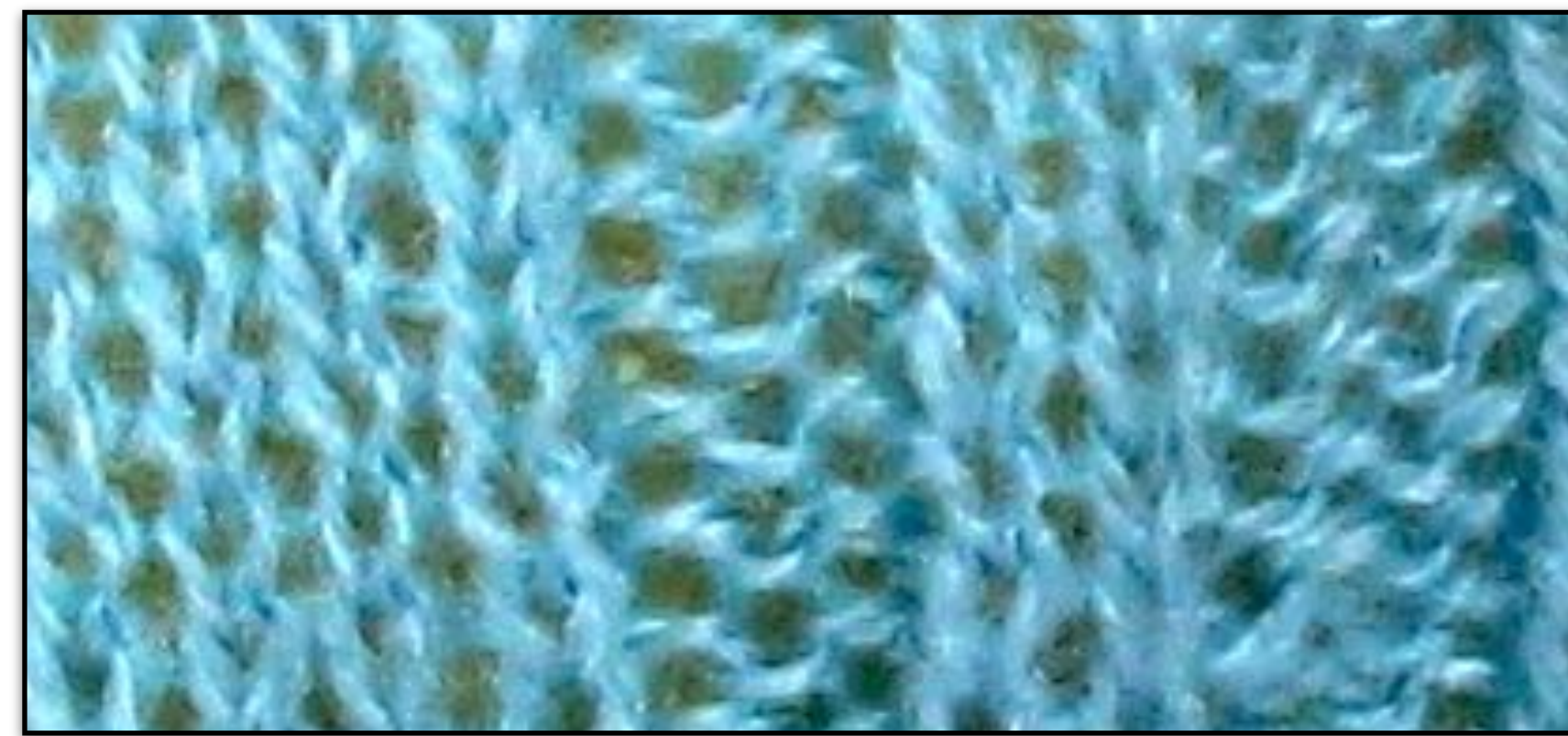
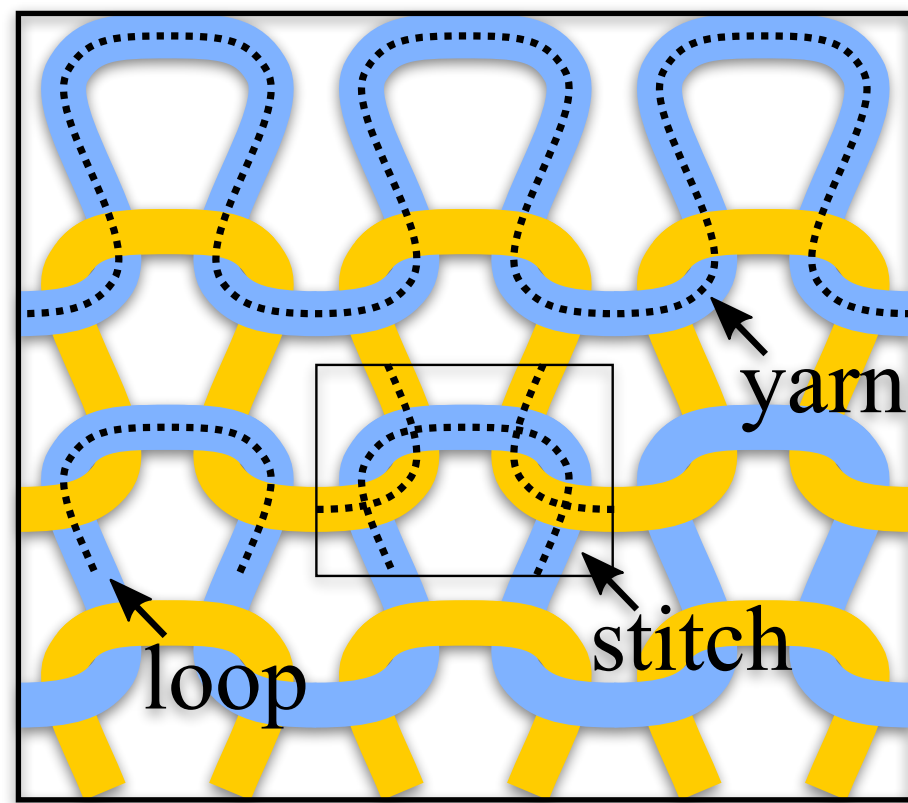

Fabric constructed using a single yarn (usually) by forming and intertwining *loops*

# Visual Knitting Machine Programming

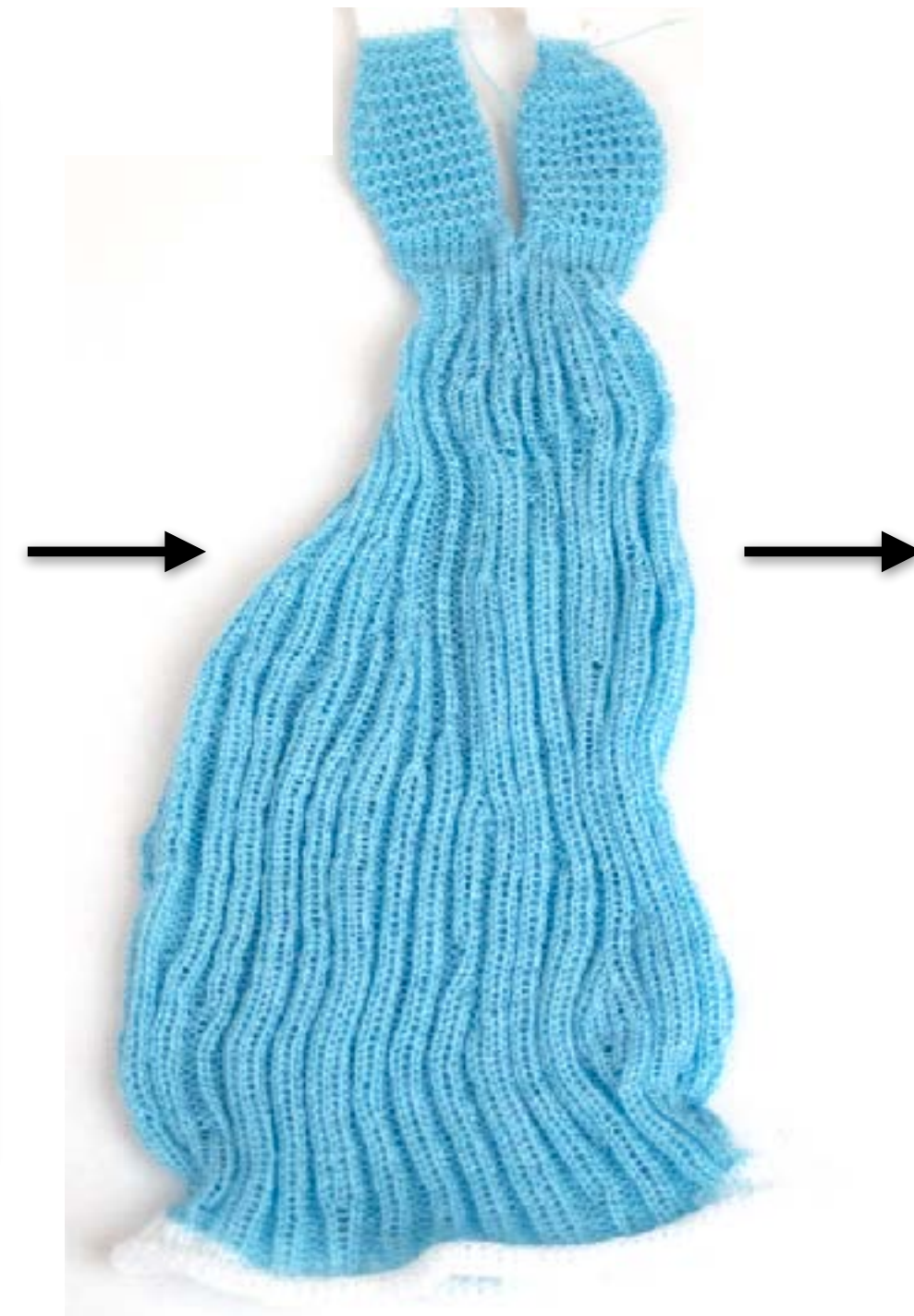
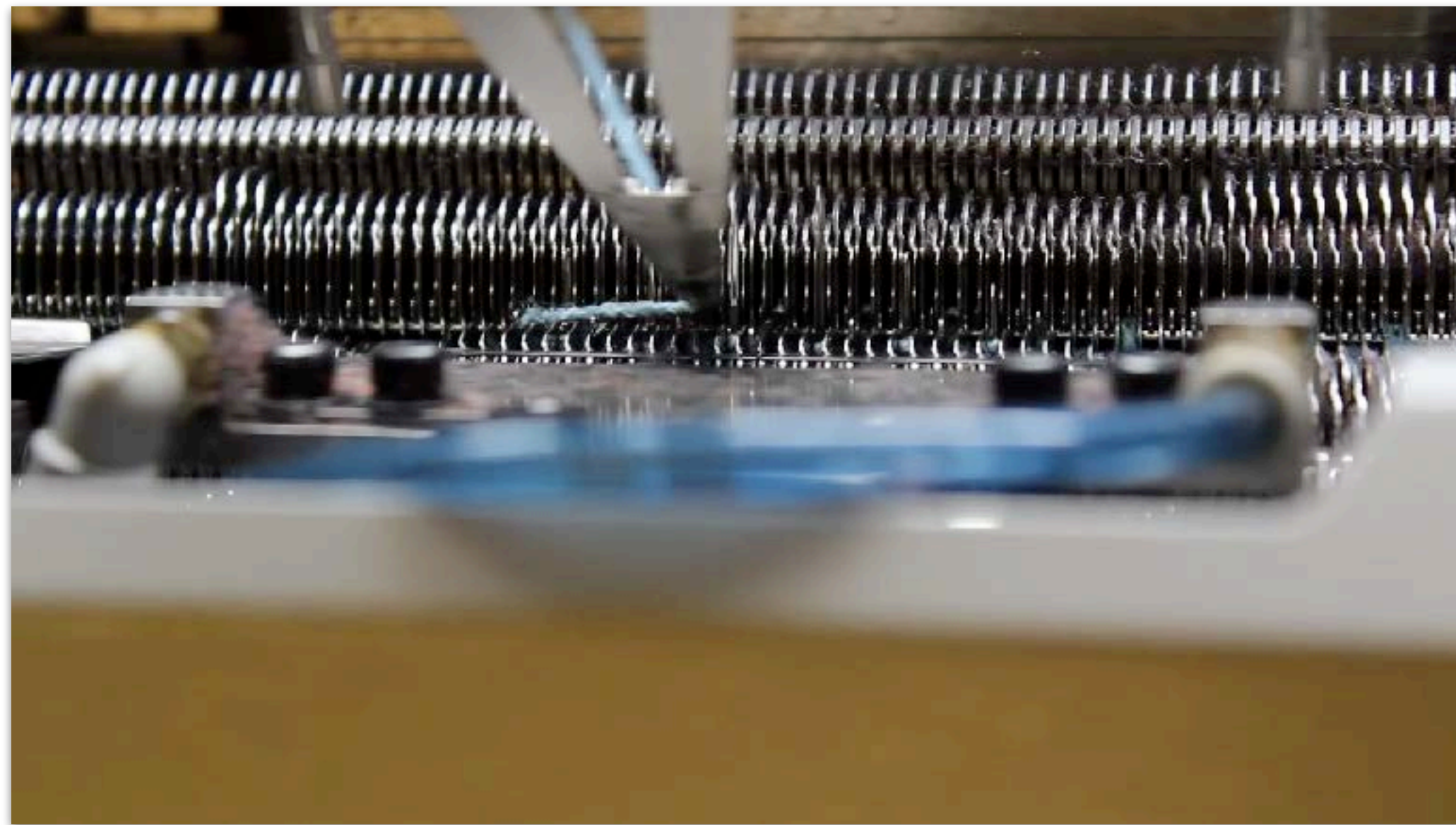

Manufactured using industrial knitting machines  
(usually used for garments)

# Visual Knitting Machine Programming

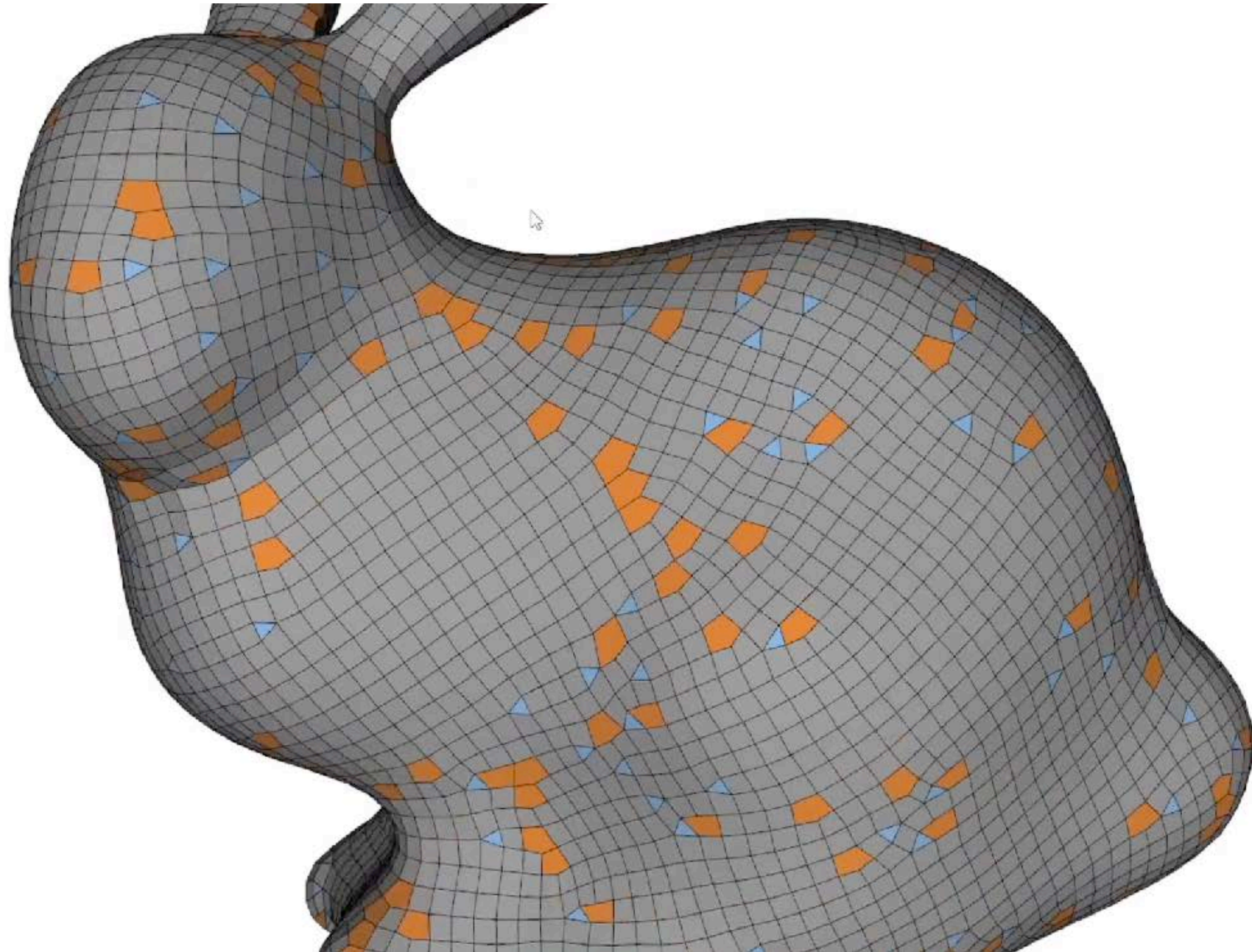

# What is Machine Knitting?

# Knitting Machine Layout

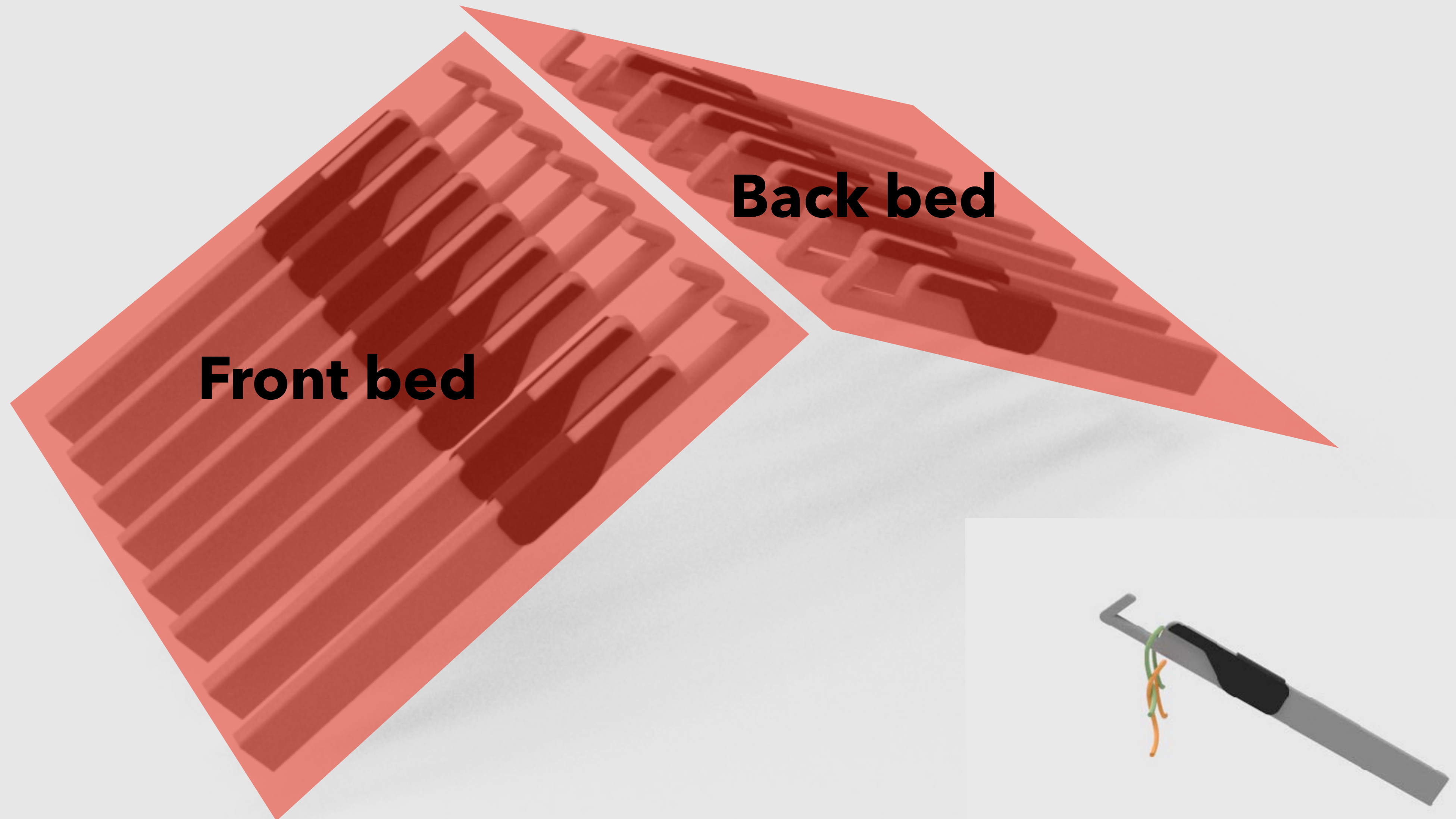

# Basic Machine Operations

*tuck*

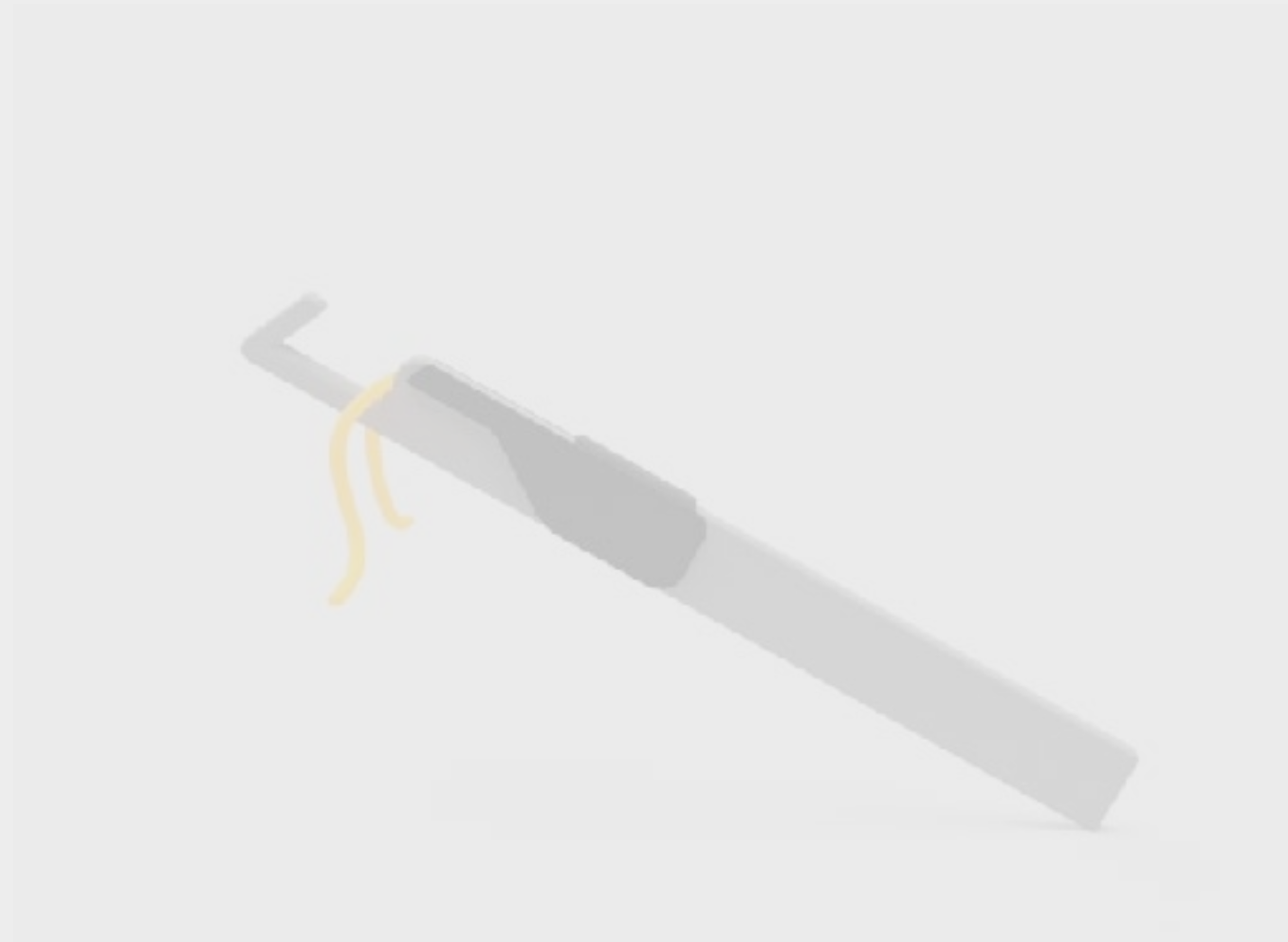

*xfer*

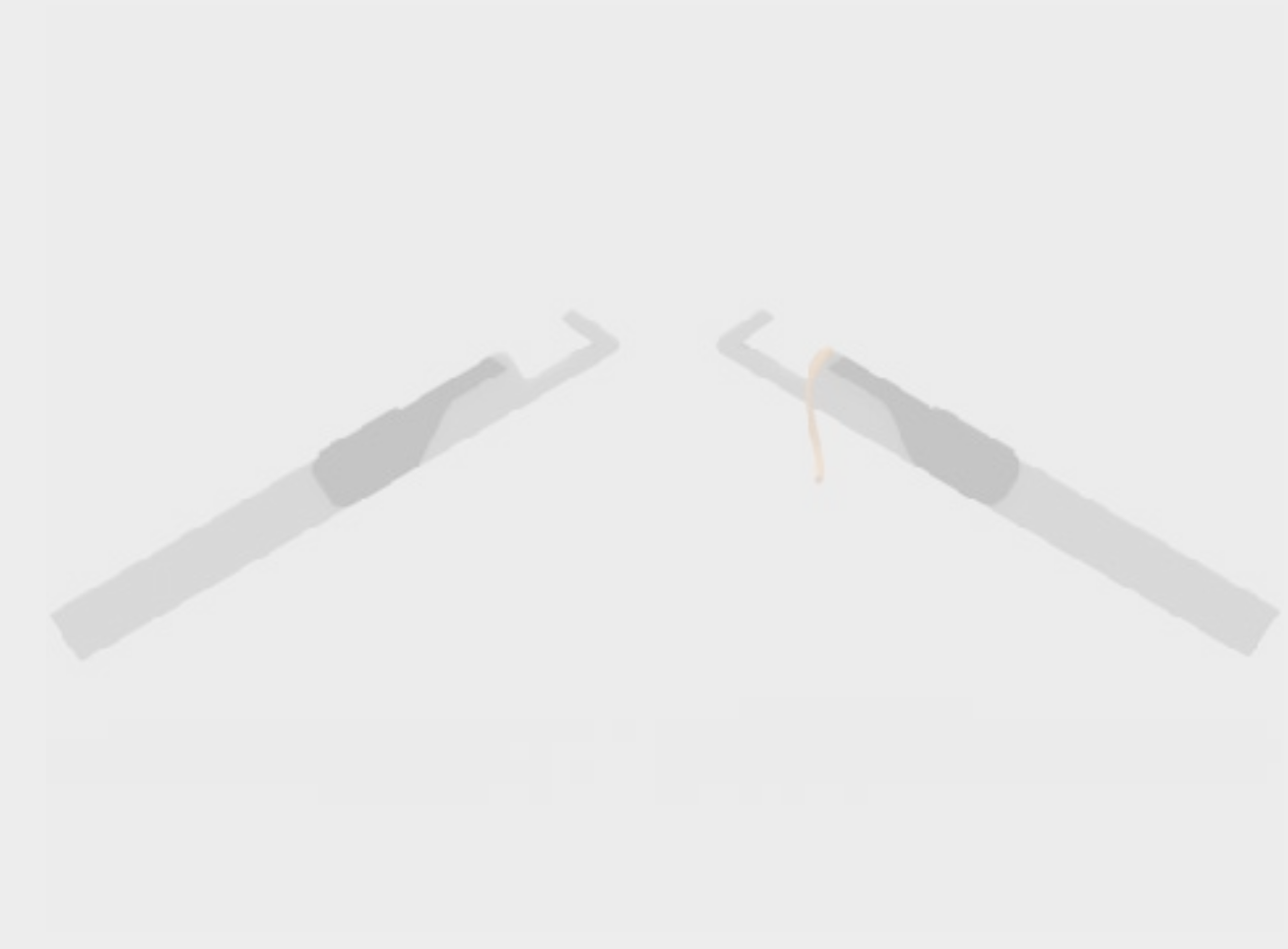

*knit*

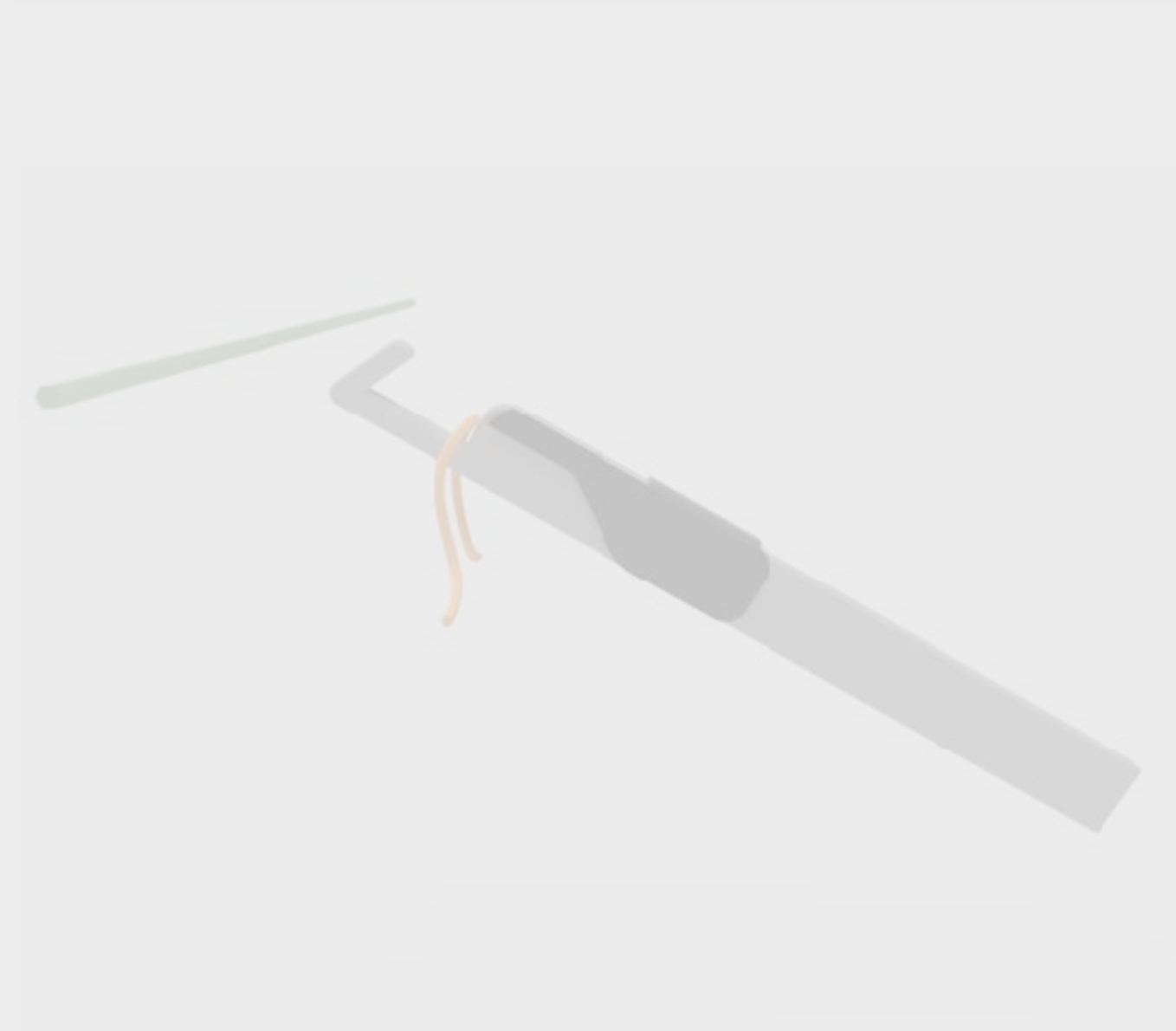

*rack*





# Basic Machine Operations

Use *xfer* and *rack* to move loops between needles

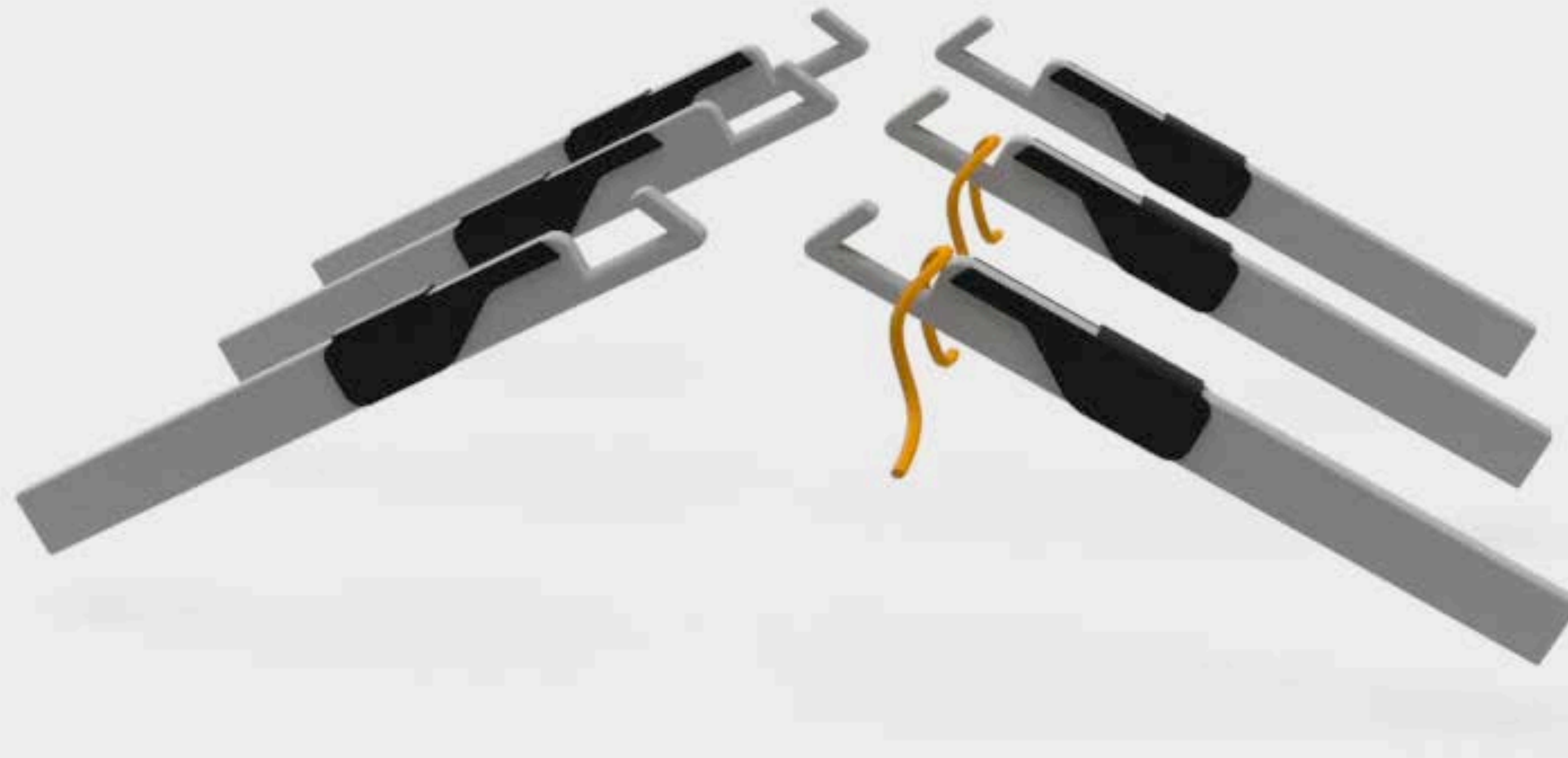

# Solutions for machine knitting

Customization

Can representation be easily edited

← to reach these capabilities.

Can it represent machine capabilities completely?



Completeness

# Solutions for machine knitting : low-level languages

Customization

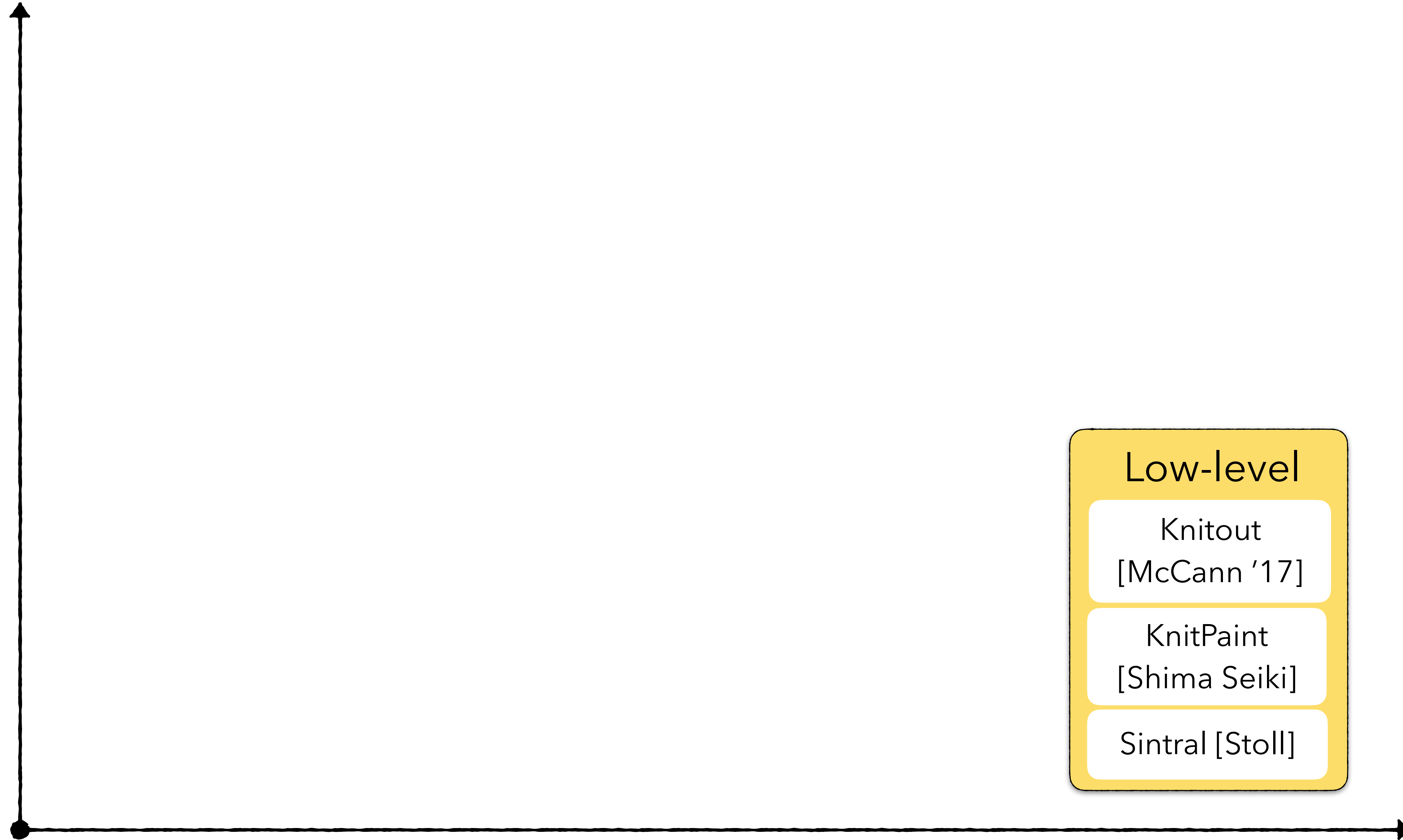

Completeness

# Solutions for machine knitting : low-level languages

Customization

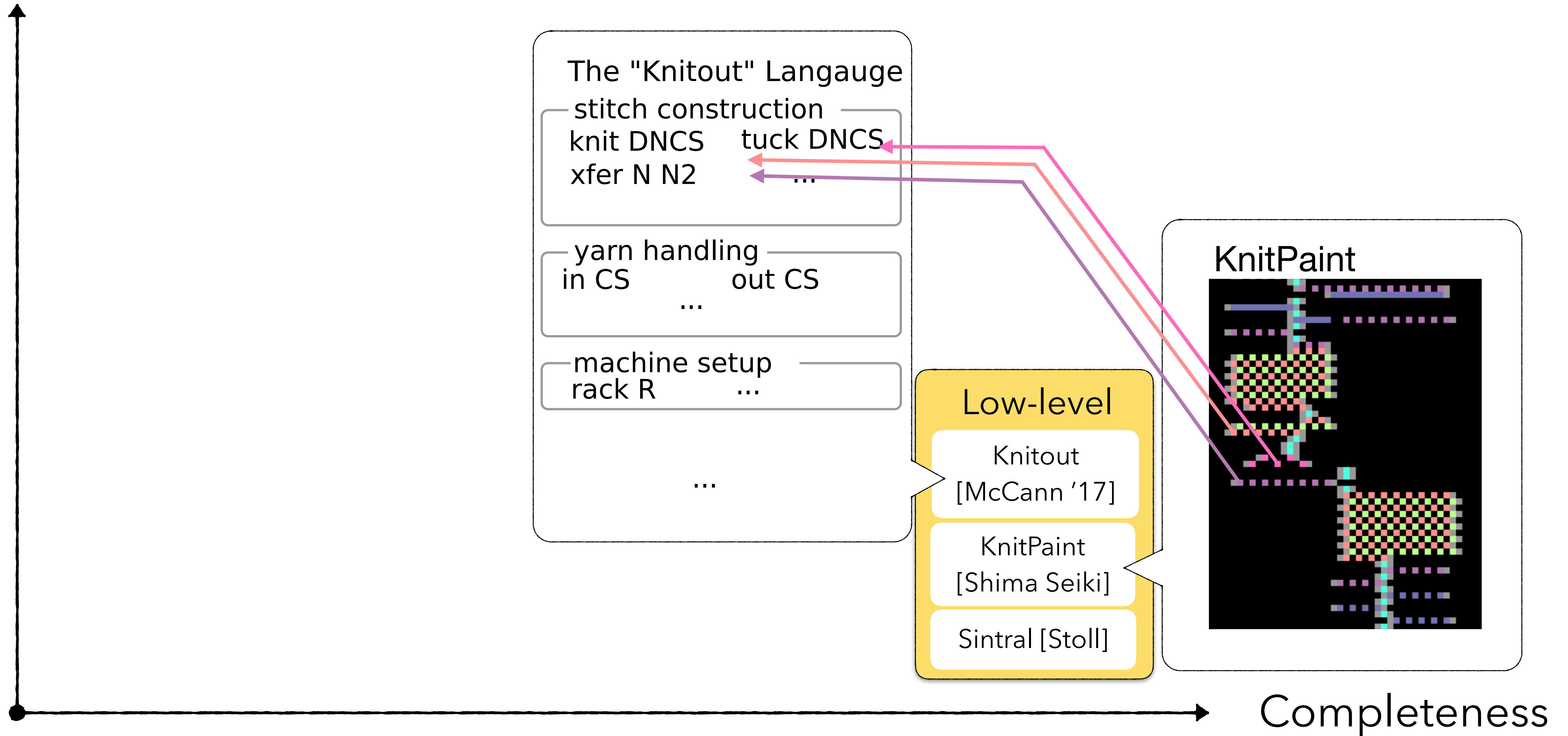

# Solutions for machine knitting : ready-made designs

Customization

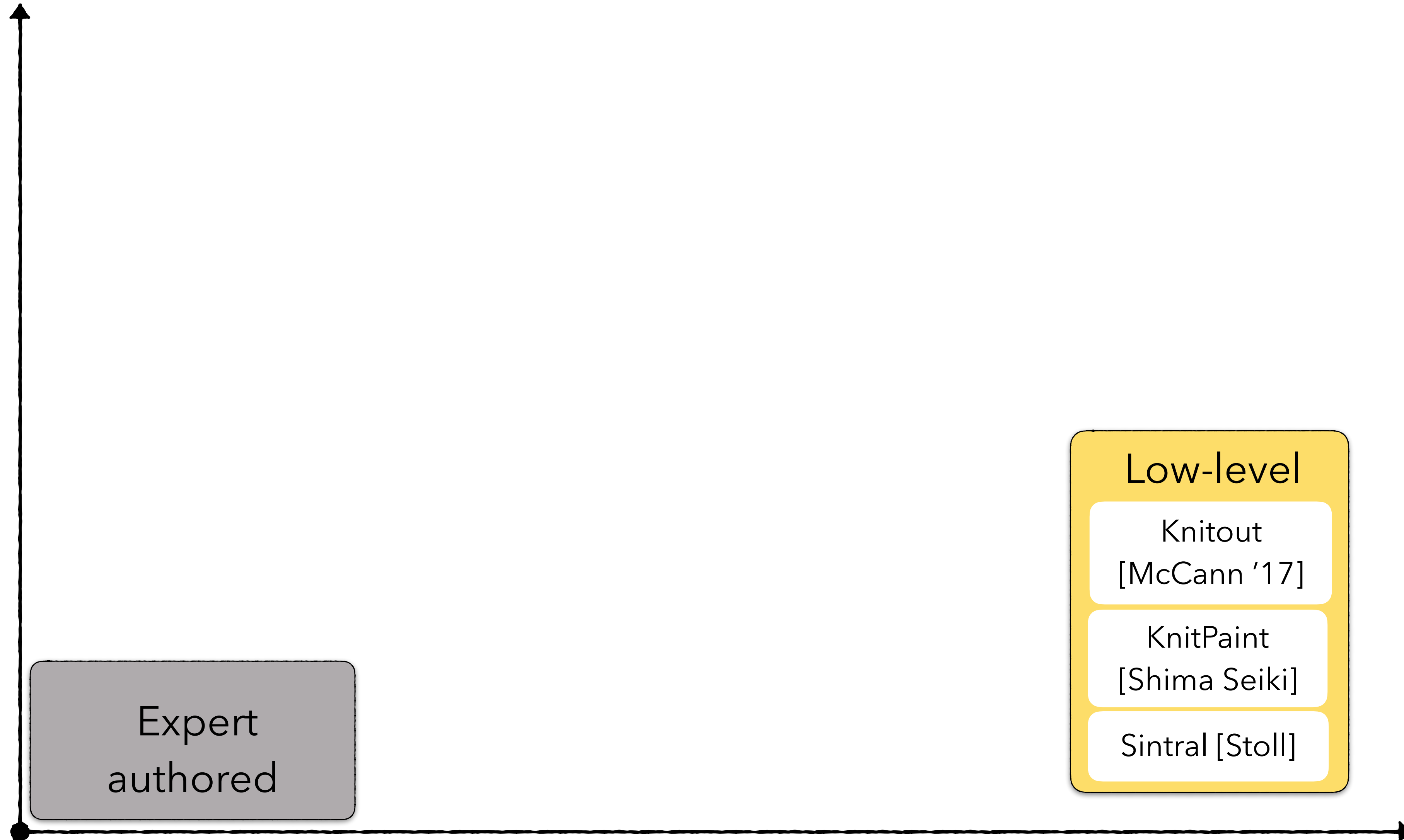

Completeness

# Solutions for machine knitting : templates

Customization

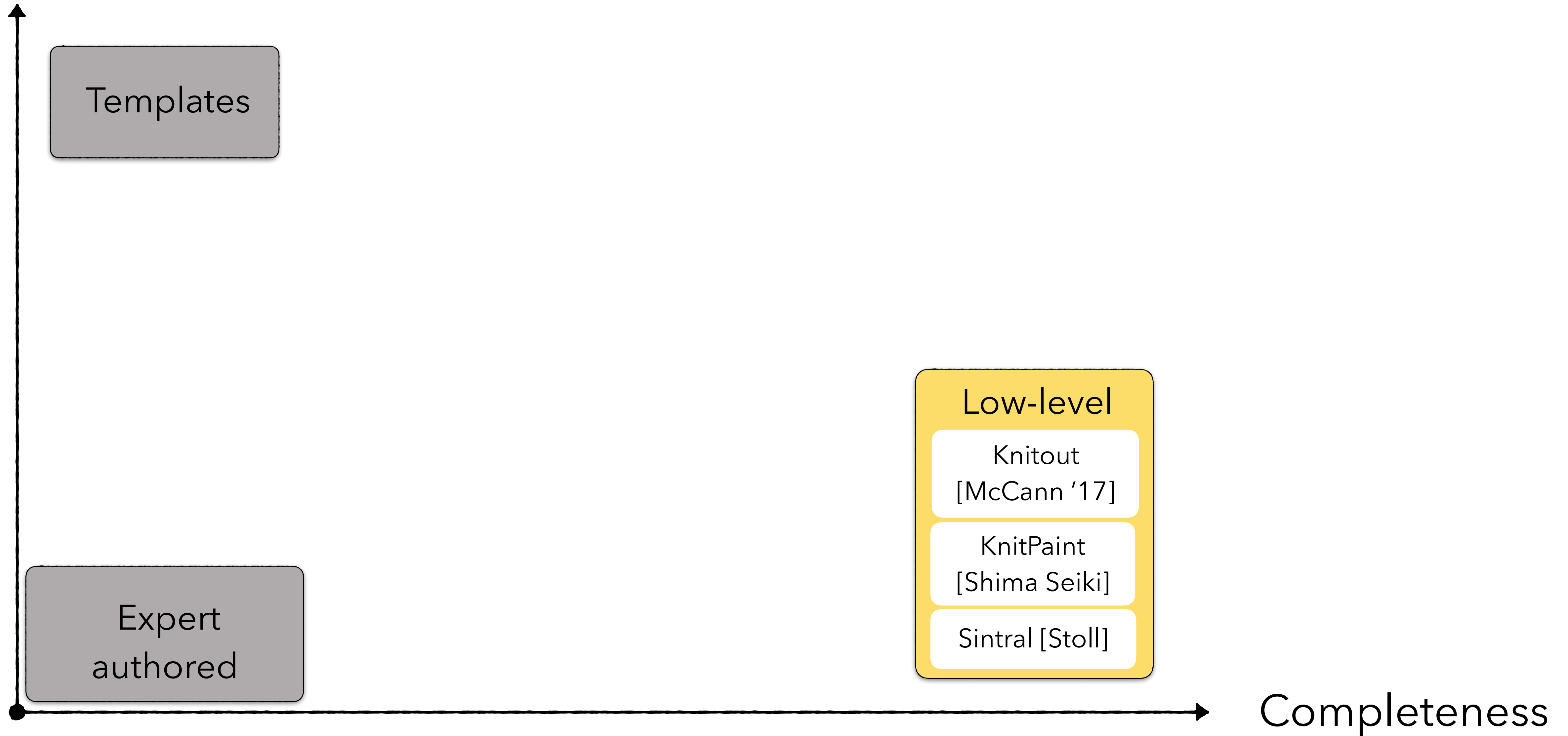

# Solutions for machine knitting : higher abstractions

Customization

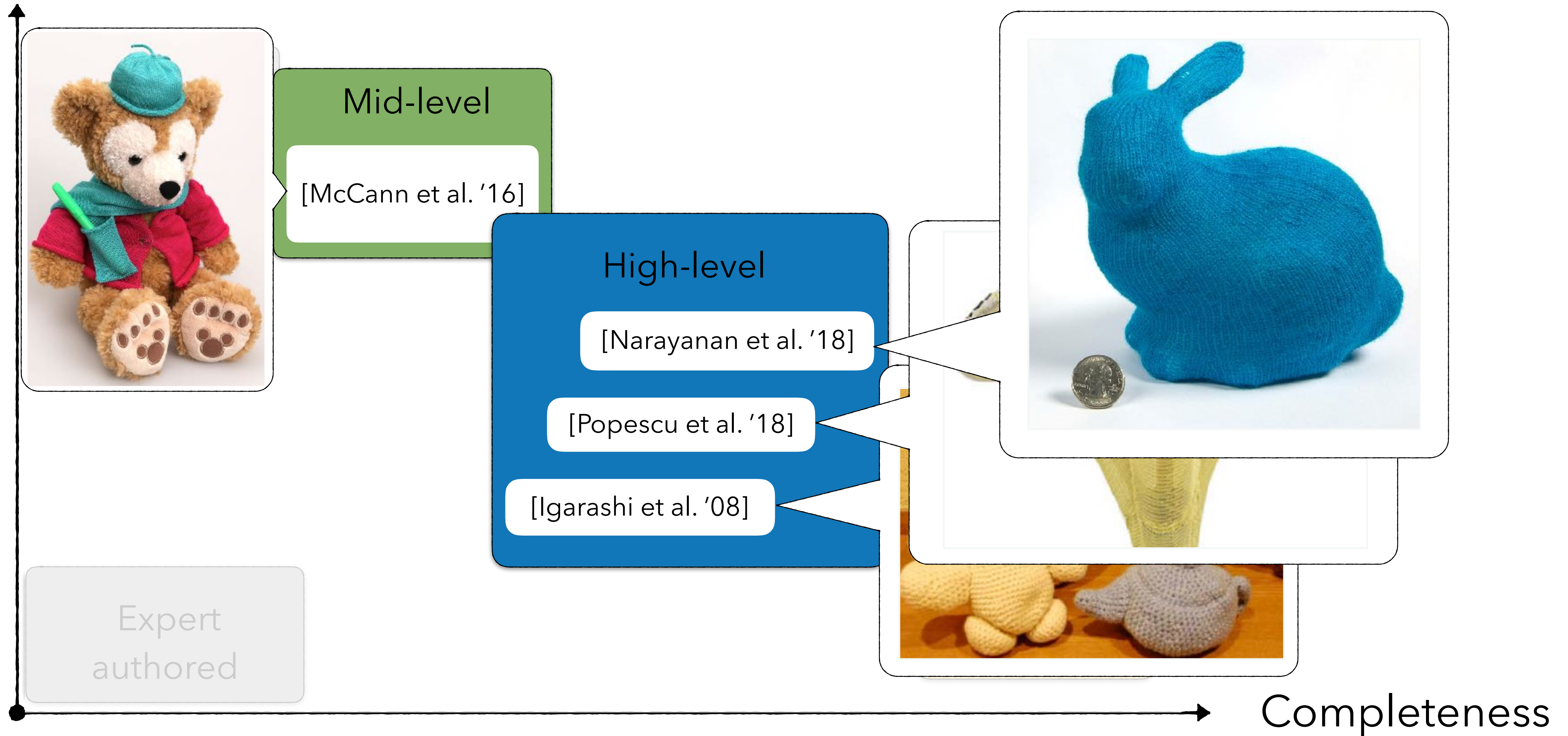

# Solutions for ~~machine~~ knitting

Customization

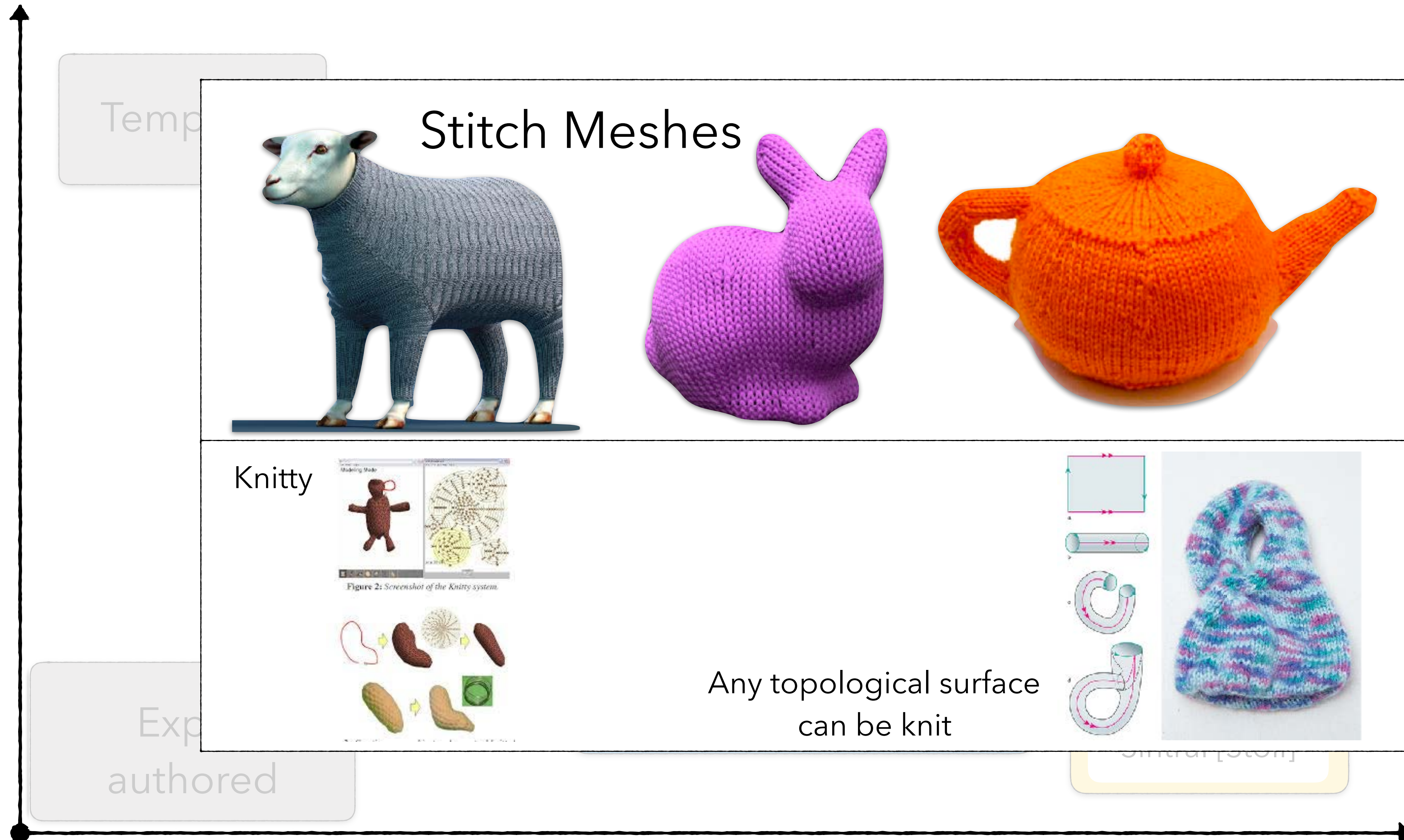

Modeling & Hand knitting

[Yuksel et al. '12]

[Wu et al '18 , '19]

[Belcastro et al. '09]

[Igarashi et al. '08]

*too complex for current hardware*

Completeness



# Solutions for machine knitting

Customization

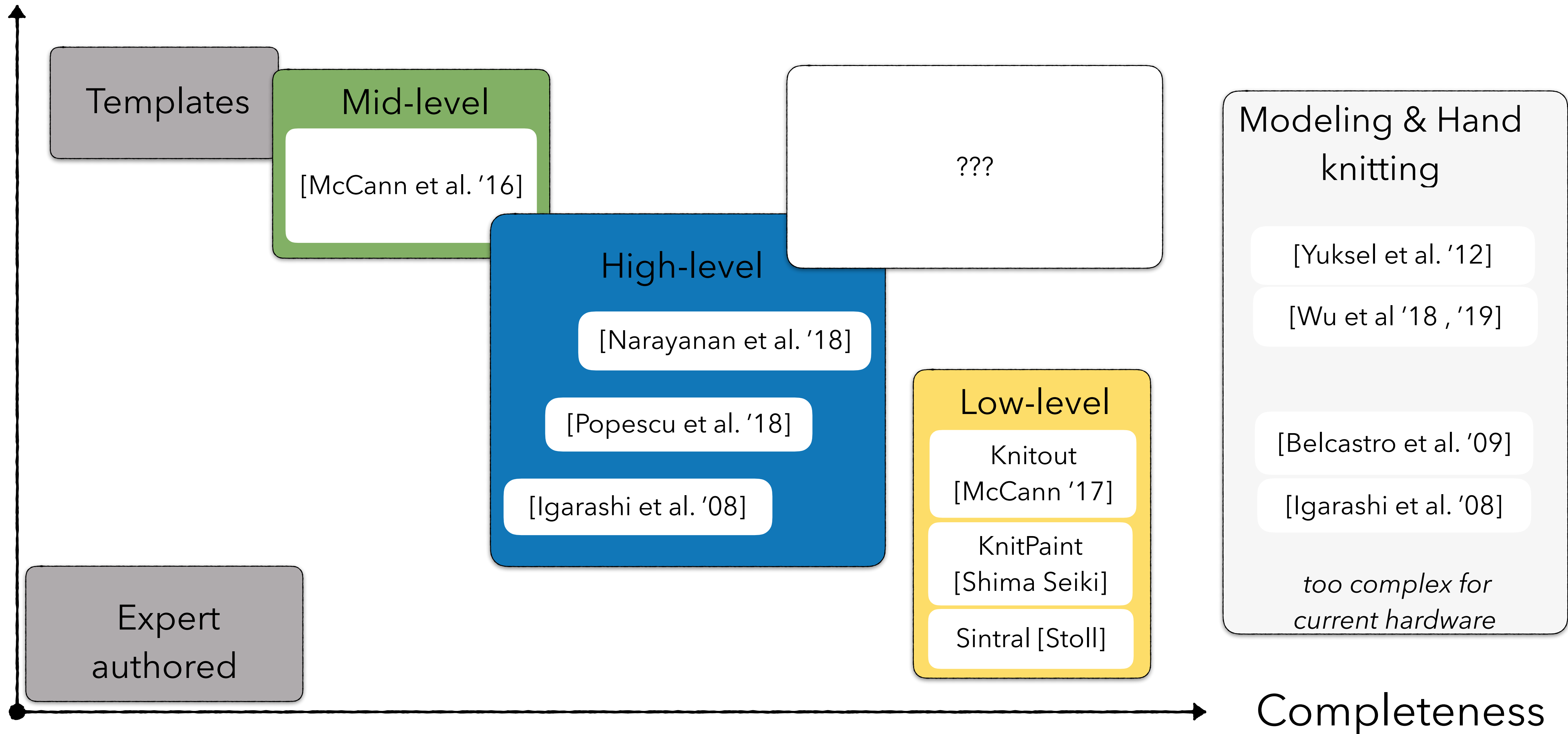

# Solutions for machine knitting

Customization

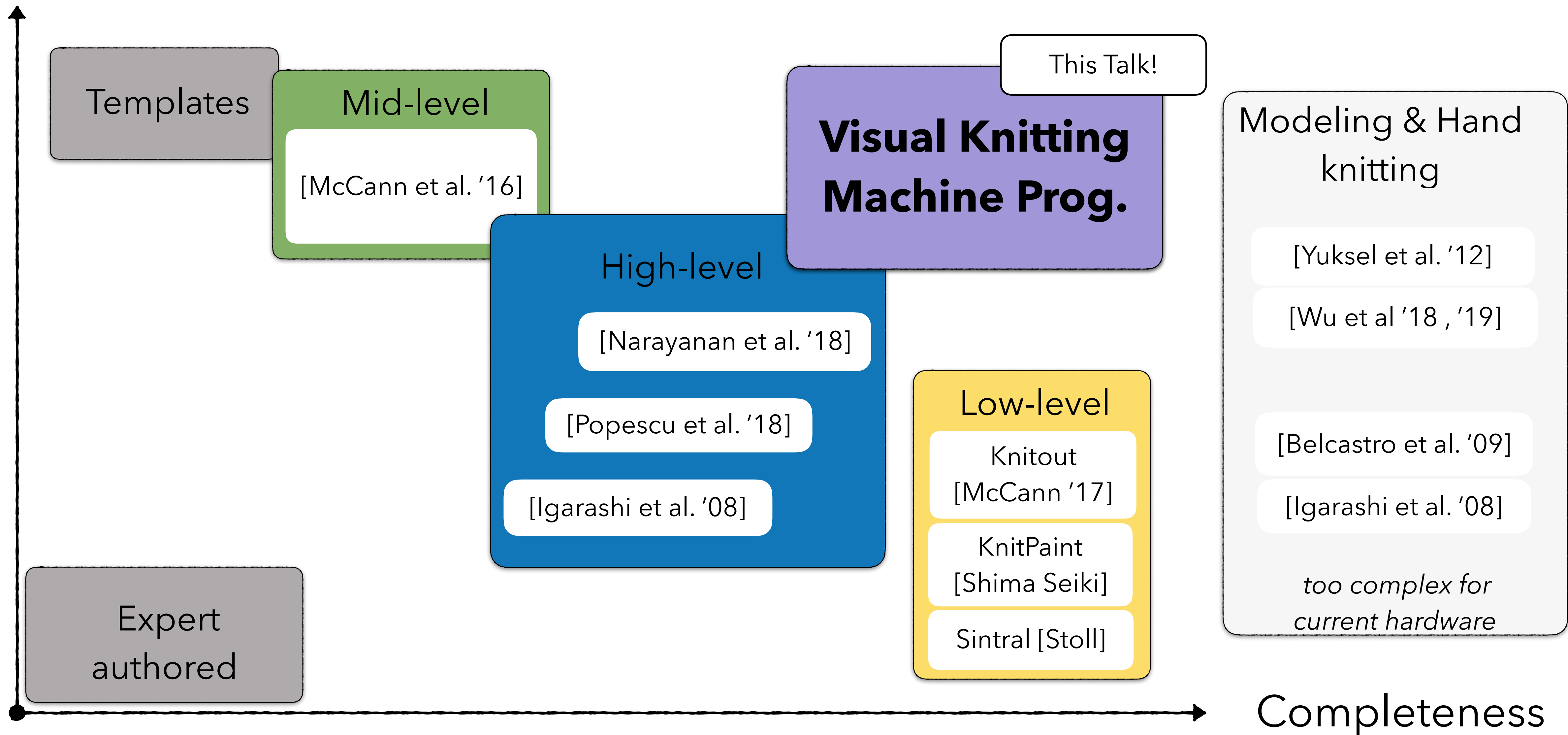

# Solutions for machine knitting

Customization

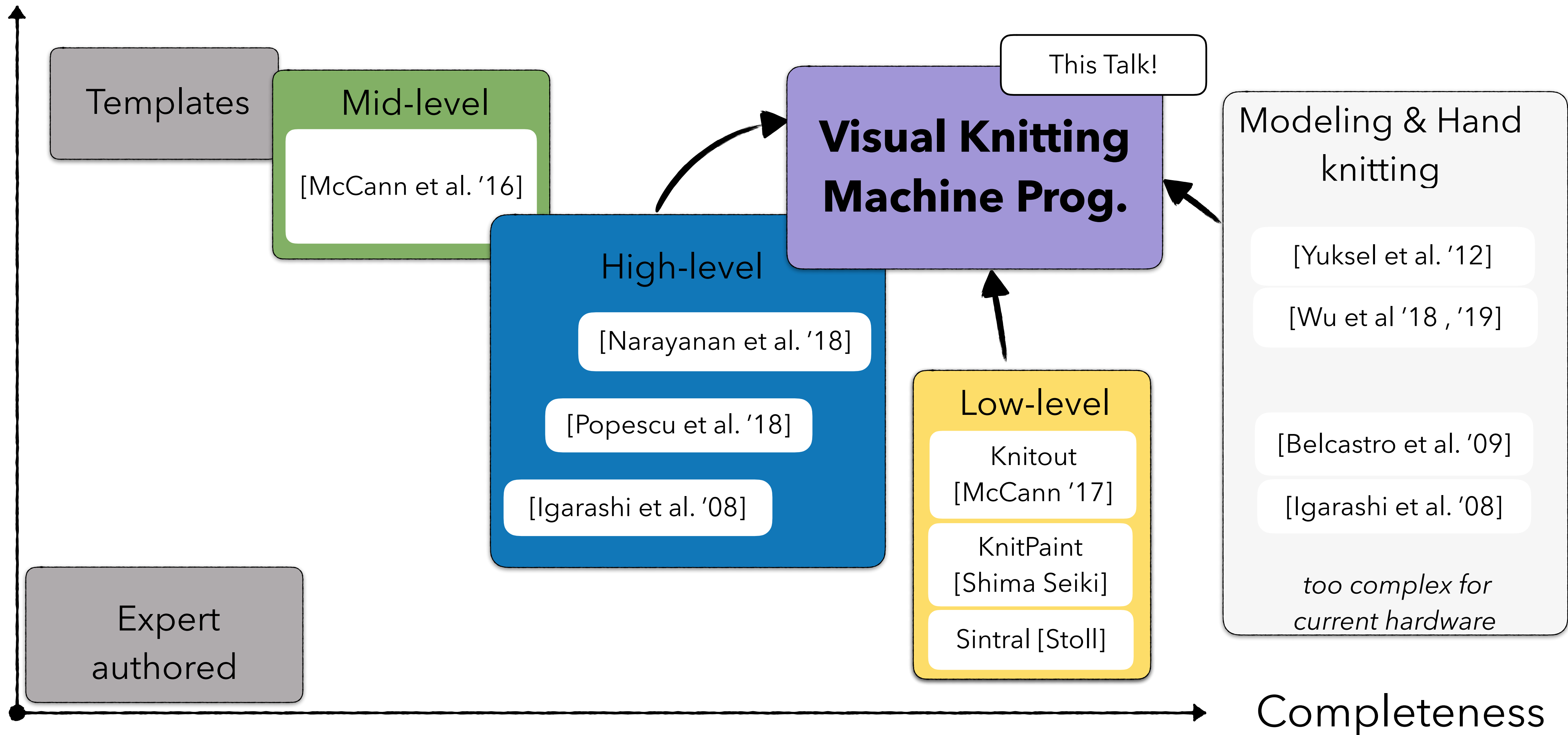

# Visual Knitting Machine Programming

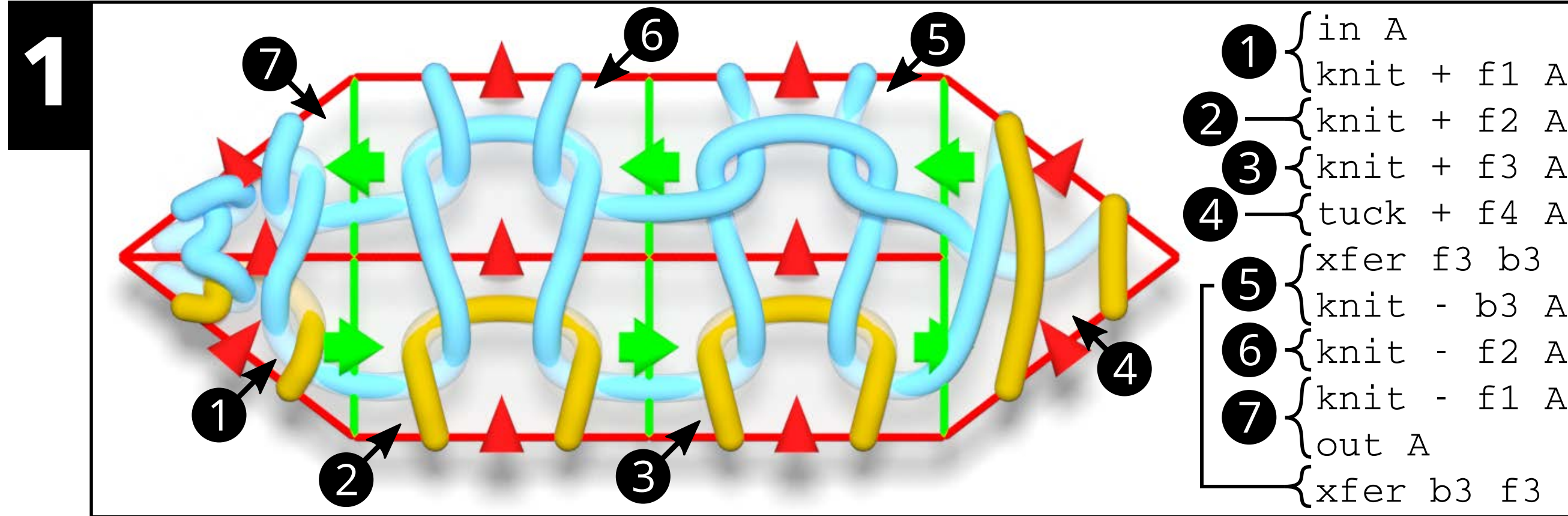

Augmented Stitch Mesh Representation

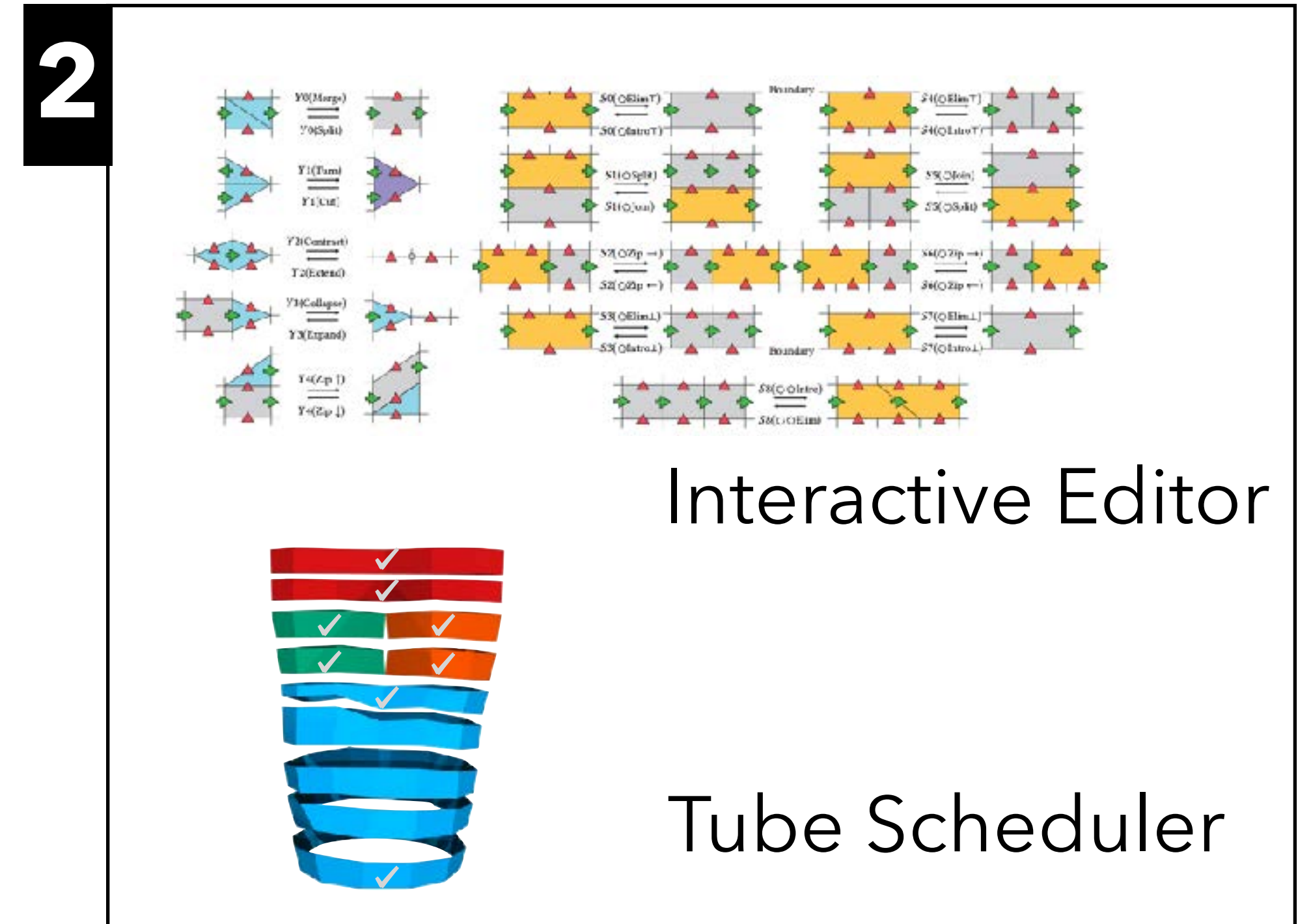

System

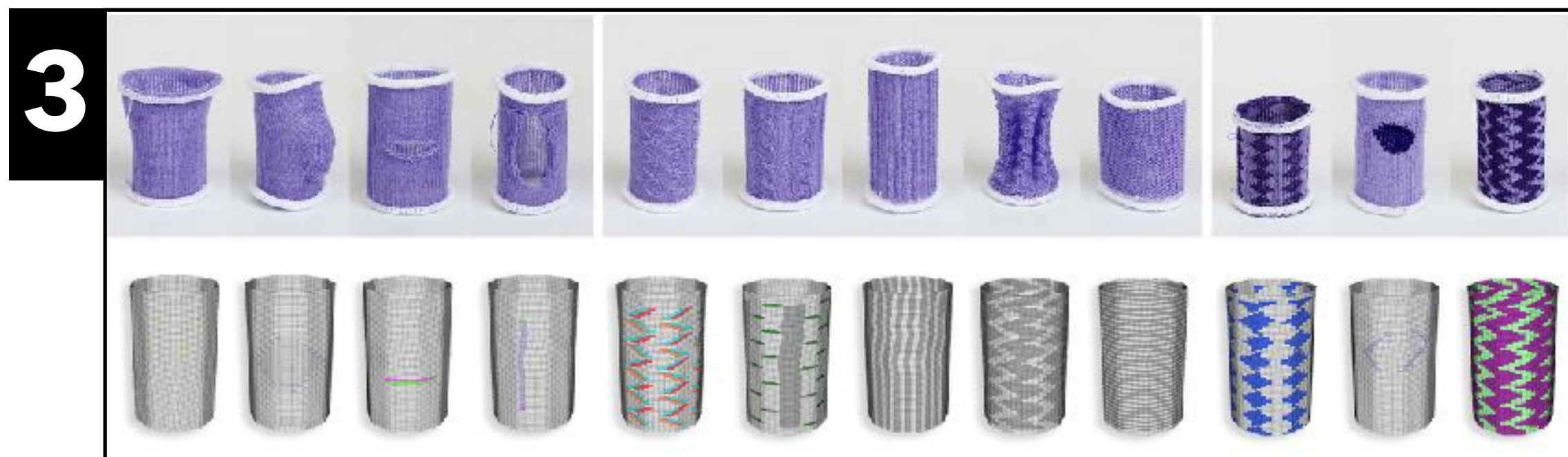

Results

# Visual Knitting Machine Programming

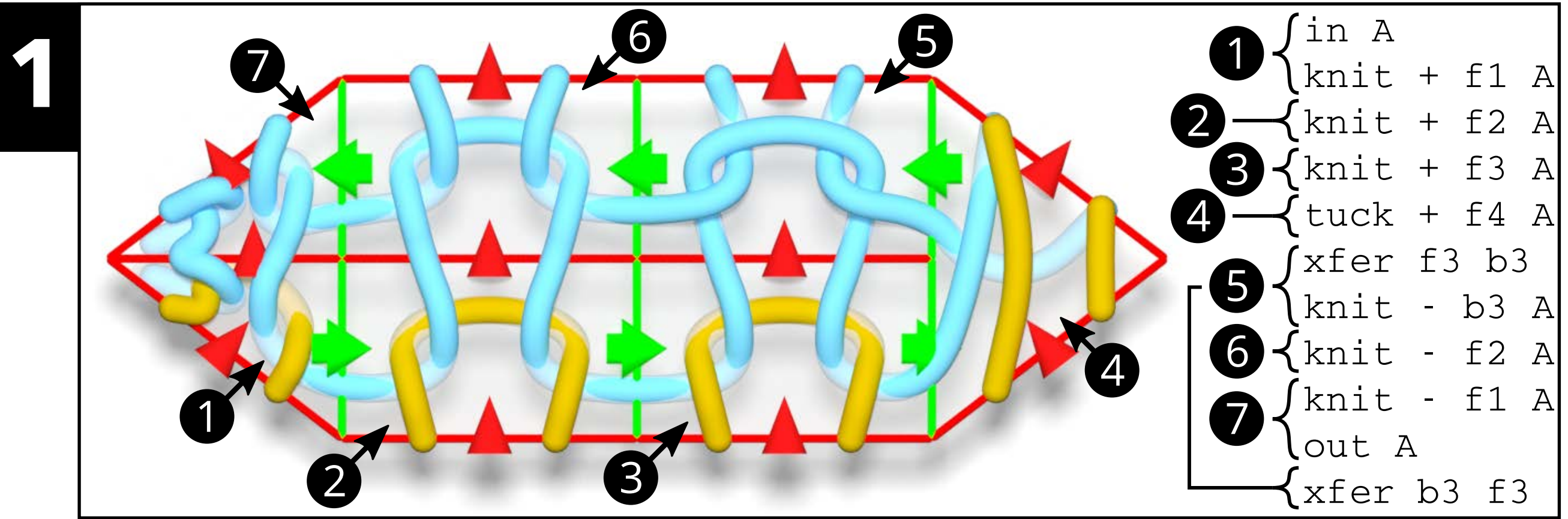

Augmented Stitch Mesh Representation

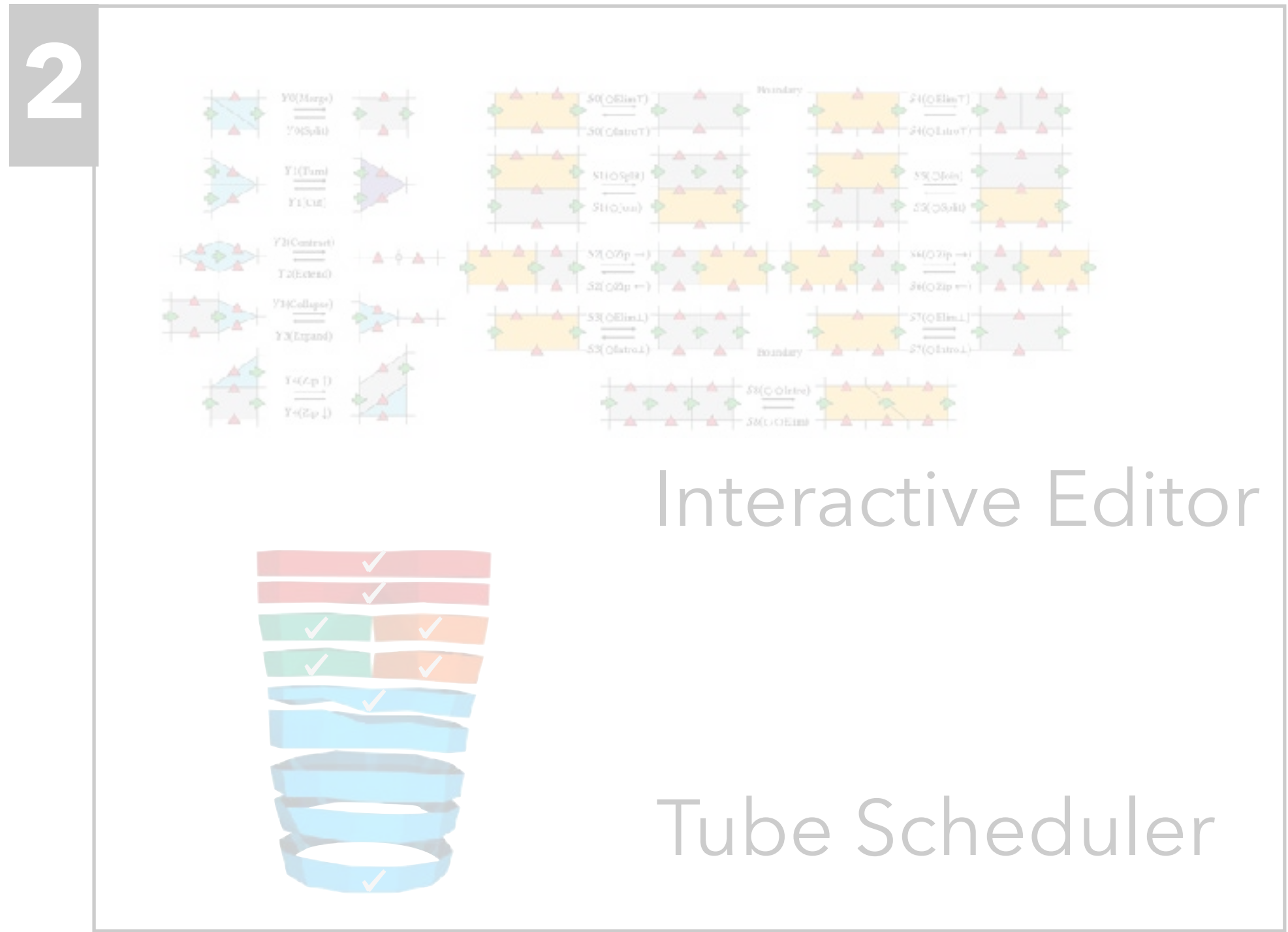

Results

# Stitch meshes for representing *machine* knittable structures

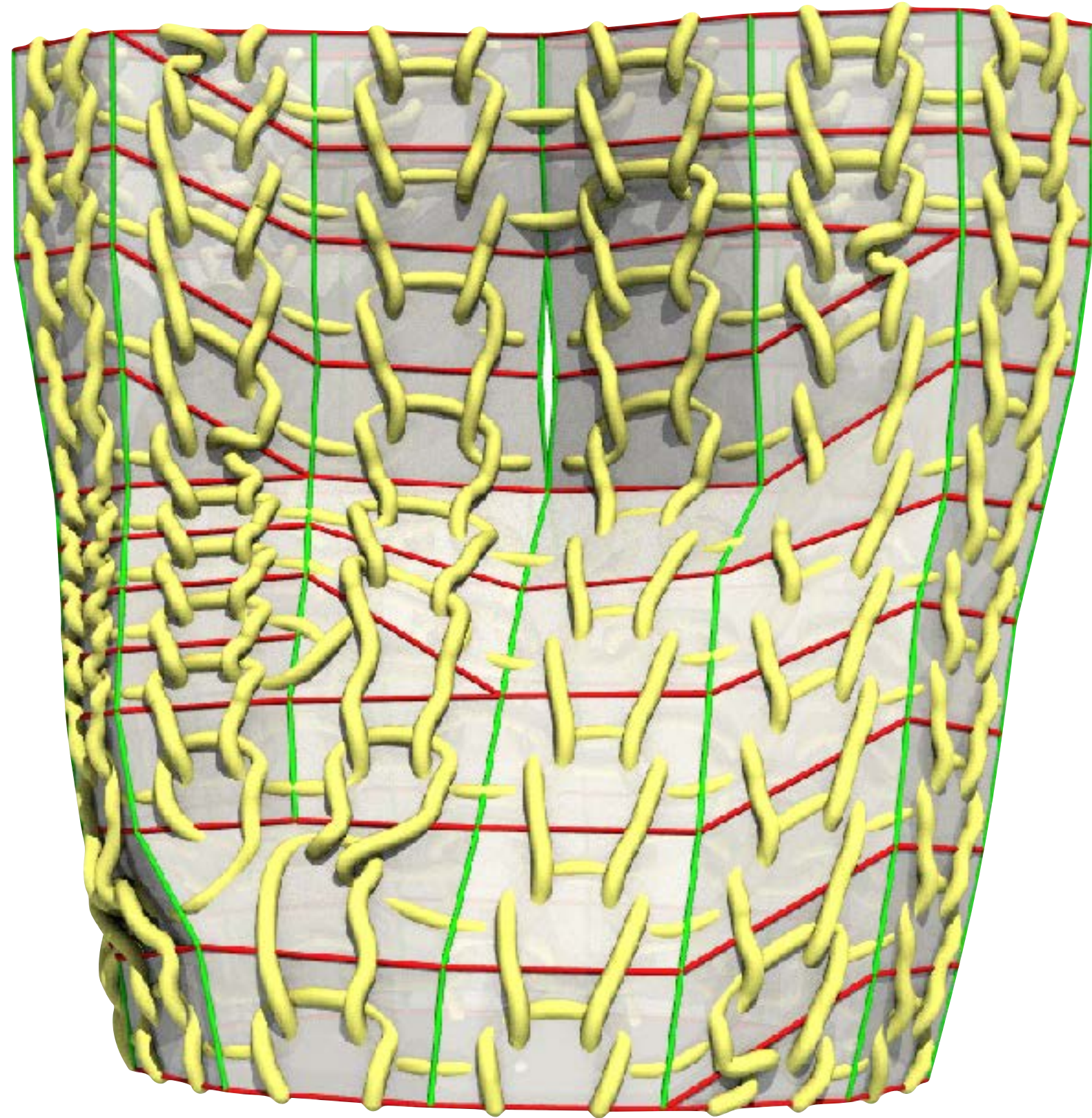

Stitch Mesh

- + Represented in the output space
- + Potentially intuitive to edit
- Can easily represent unknittable configurations (cycles).
- Machine instructions for fabrication are unknown.

# Encoding dependencies with edge directions

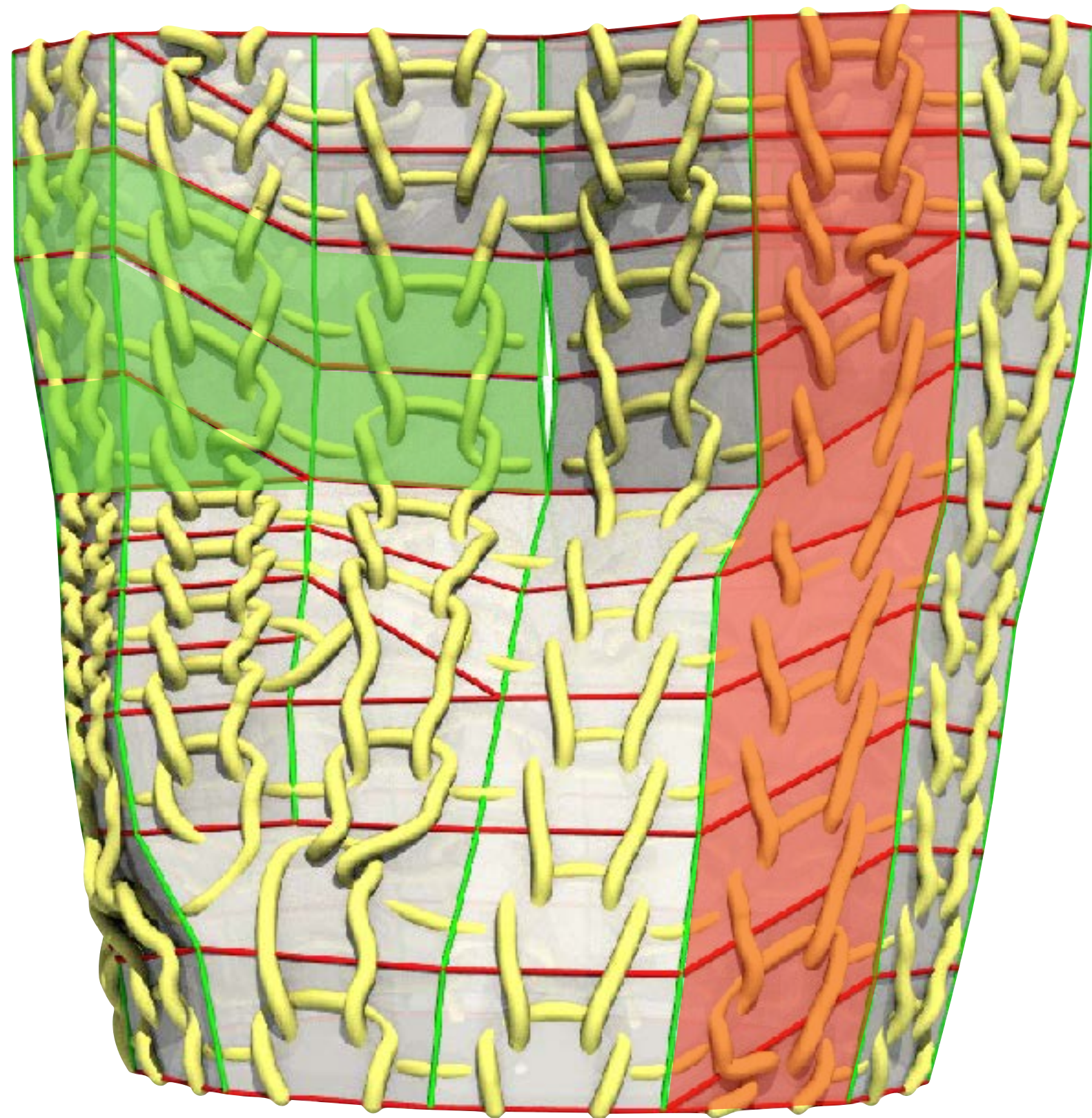

Stitch Mesh

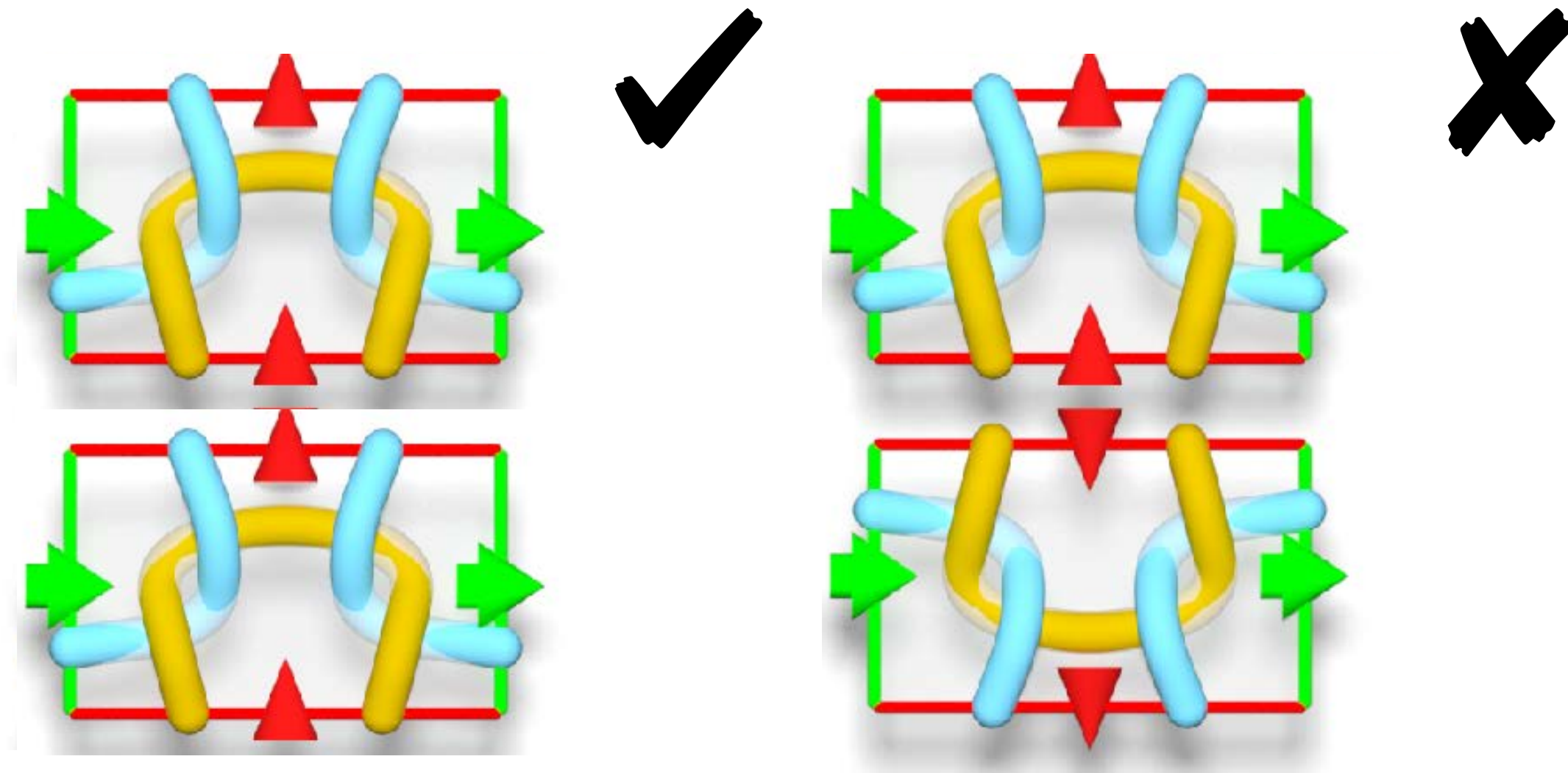

**Only directed acyclic stitch meshes are valid.**

# Encoding face programs for construction

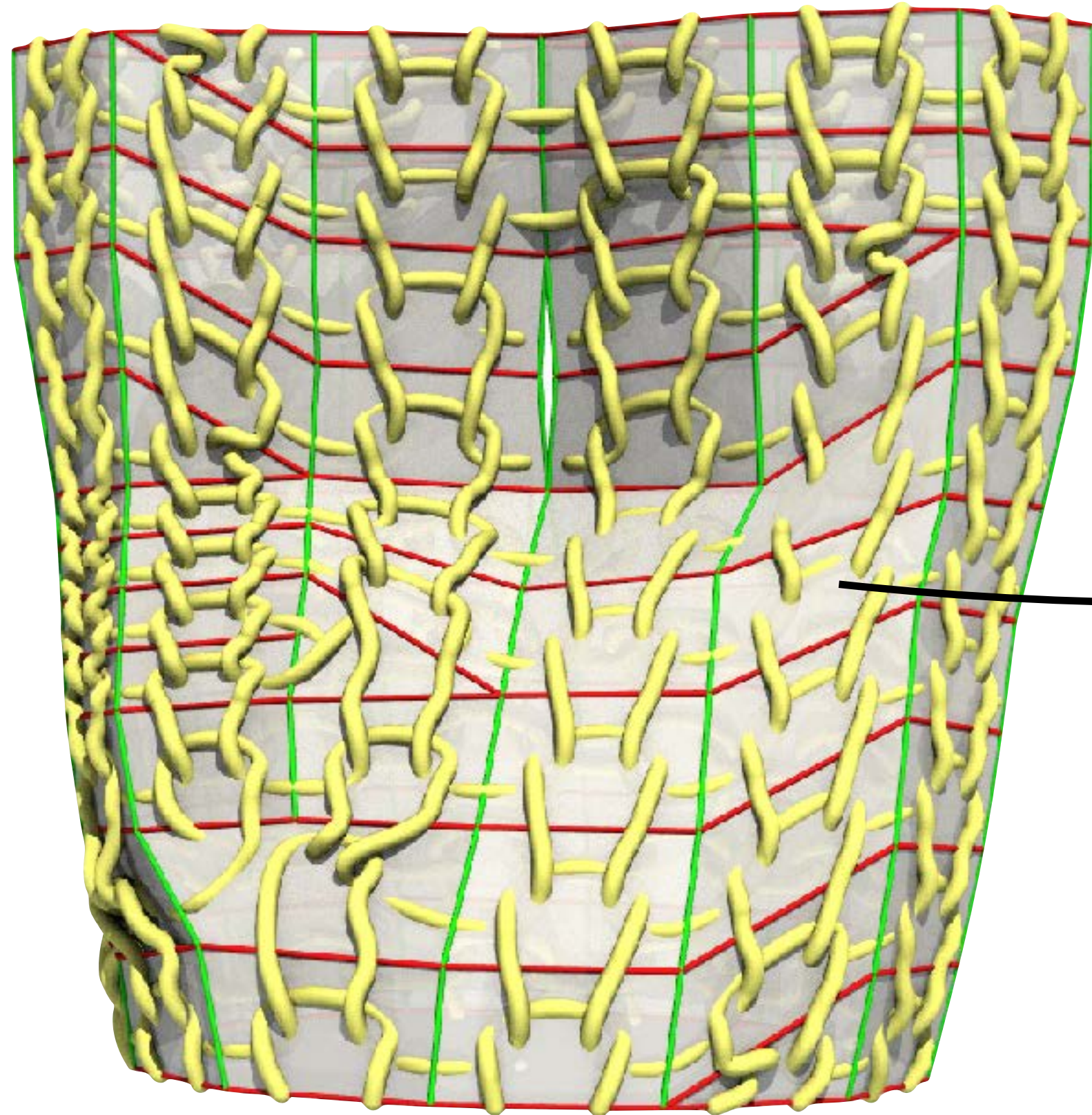

+ Represented in the output space  
**Decouple what is constructed from where it is constructed.**  
+ Potentially intuitive to edit

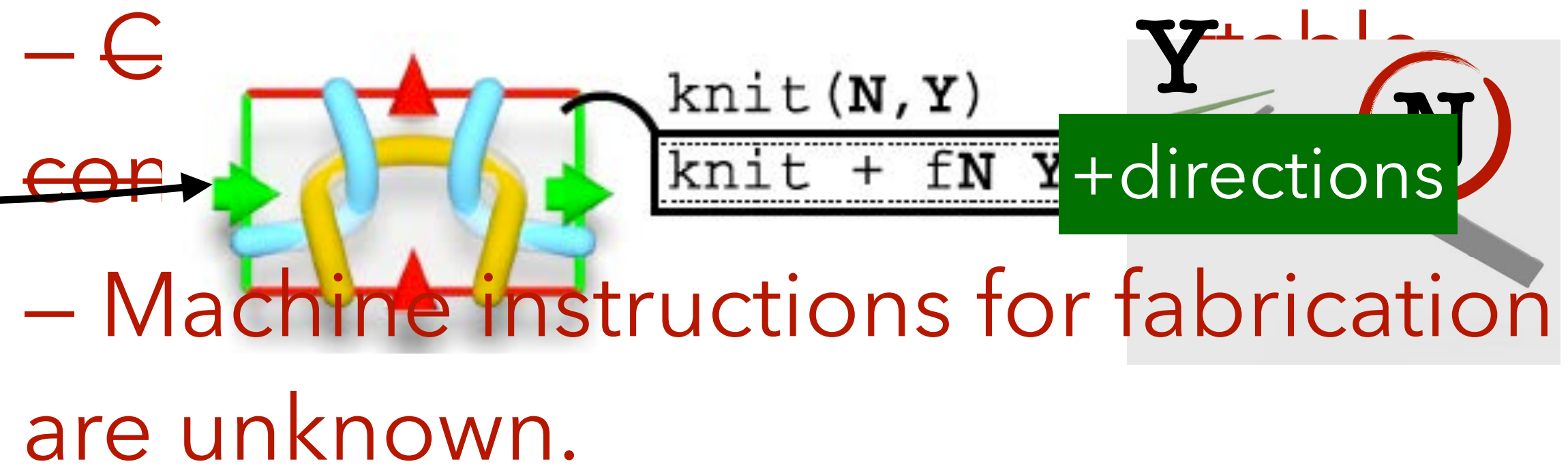

Stitch Mesh + Directions



# Augmented Stitch meshes for machine knittable structures

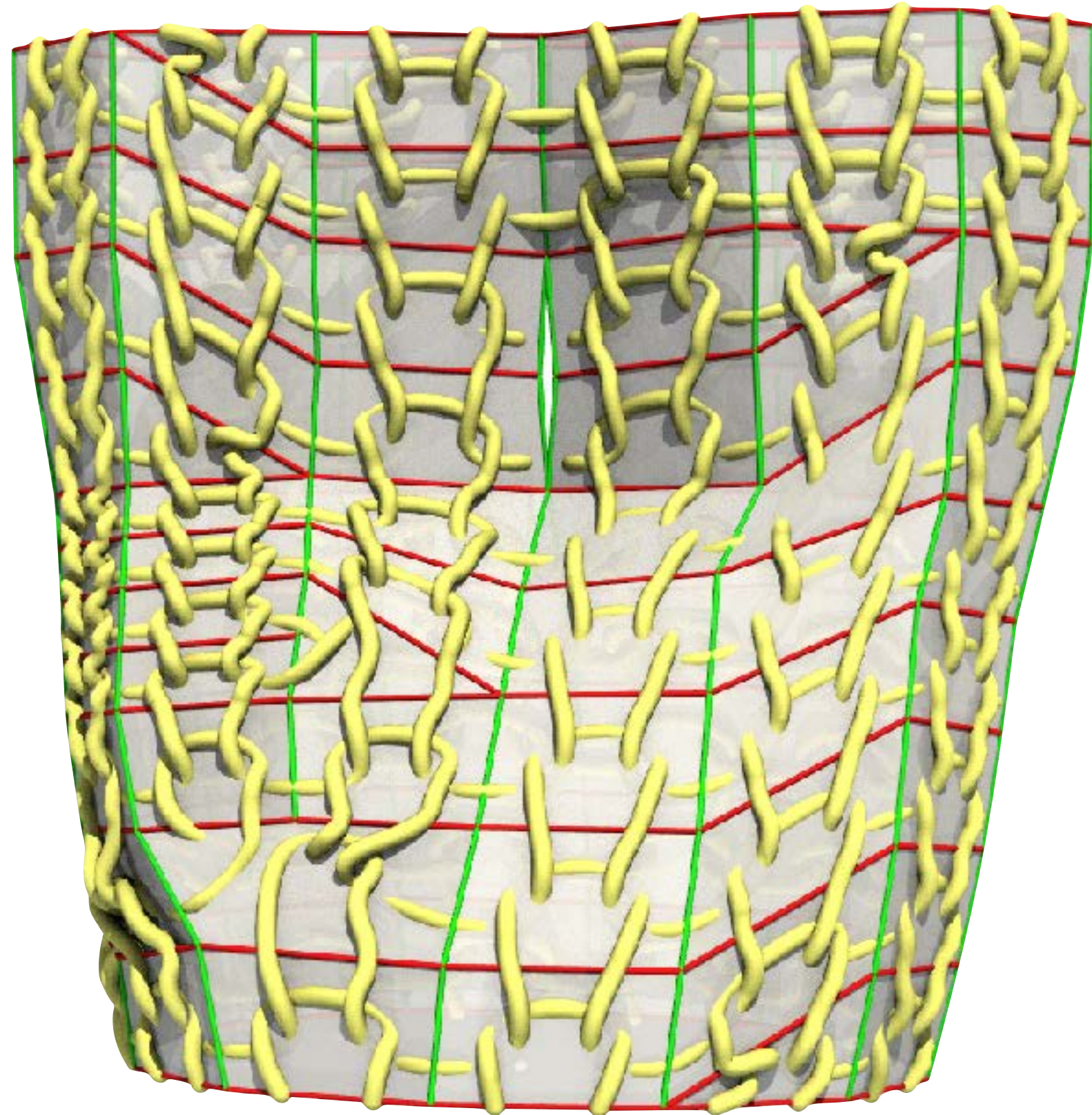

+ Represented in the output space

+ Potentially intuitive to edit

~~— Can easily represent unknittable configurations (cycles).~~ +directions

~~— Machine instructions for fabrication are unknown.~~ +code

Stitch Mesh + Directions + Code = **Augmented Stitch mesh**

# Only a small library of face programs needed

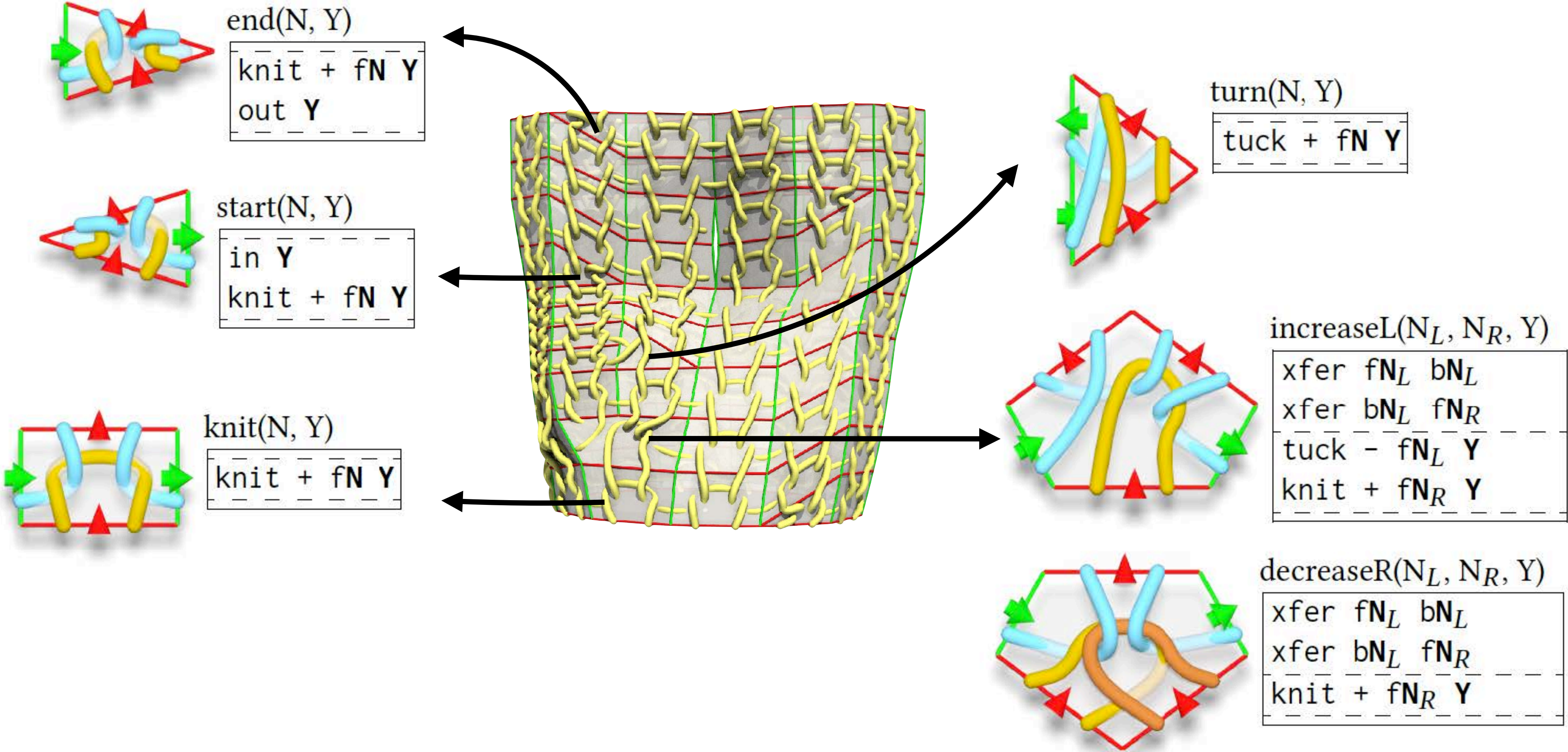

# Edge labels do not imply face programs

**Any compatible face program can be executed within a face.**

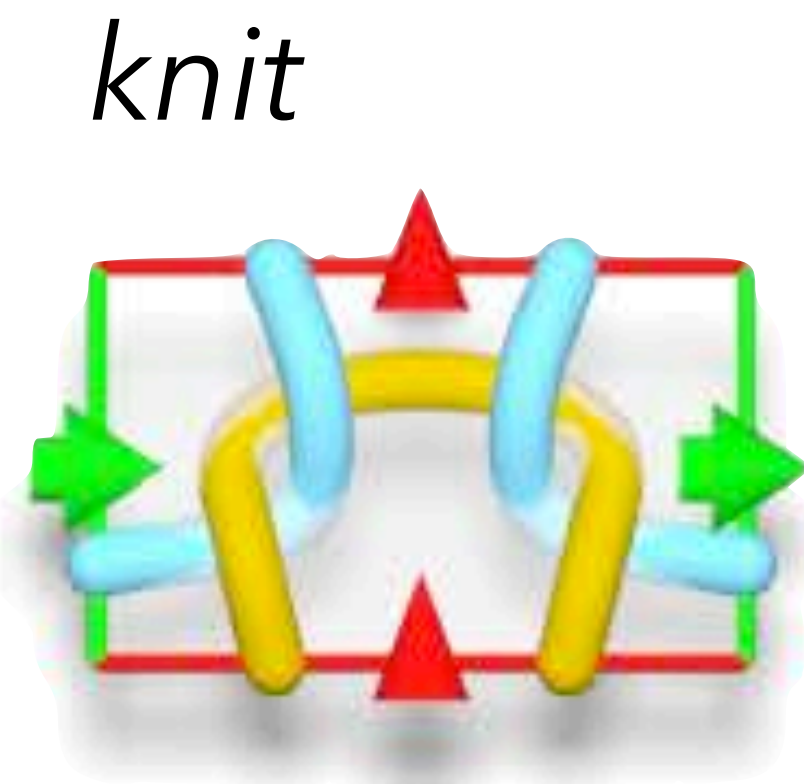

knit(N, Y)

knit	+	fN	Y
------	---	----	---

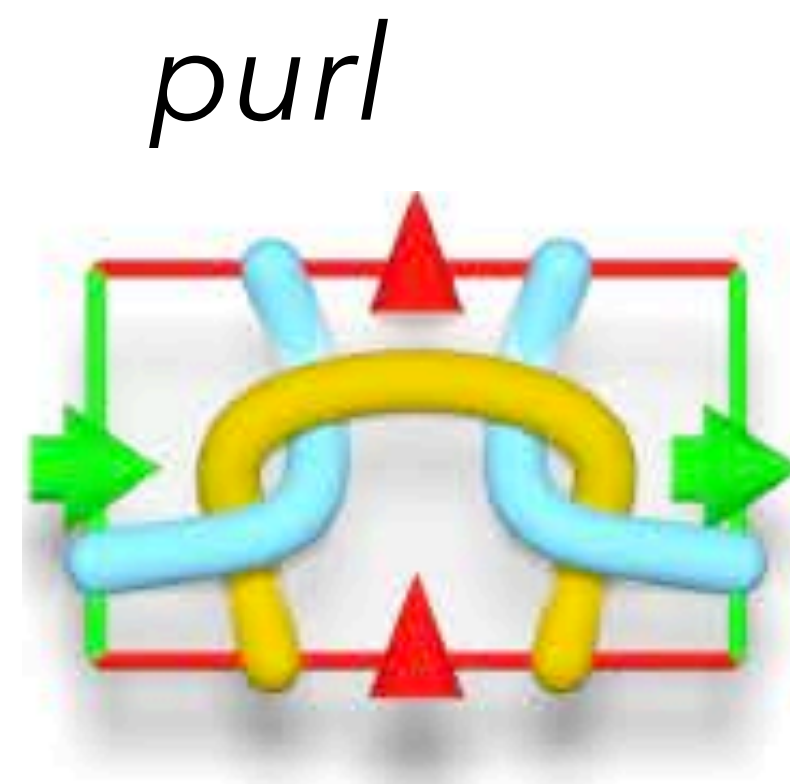

purl(N, Y)

xfer	fN	bN
knit	+	bN Y
xfer	bN	fN

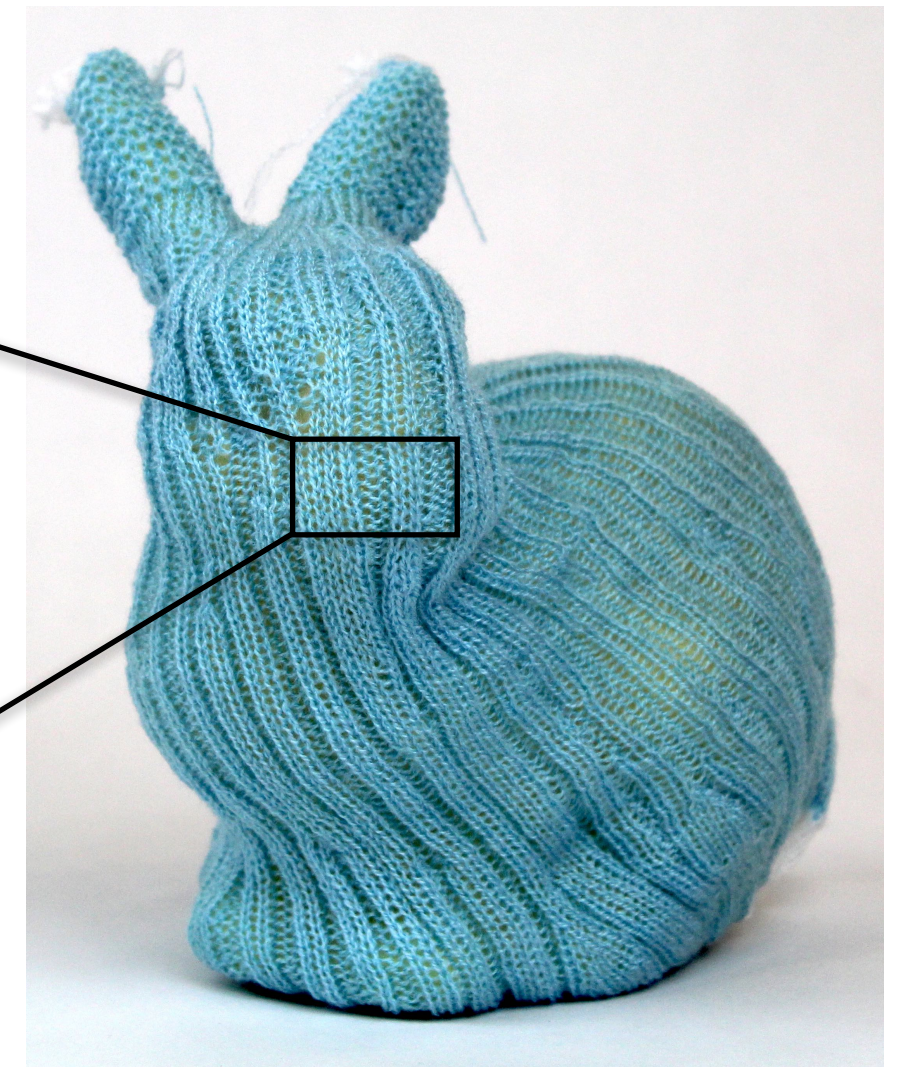
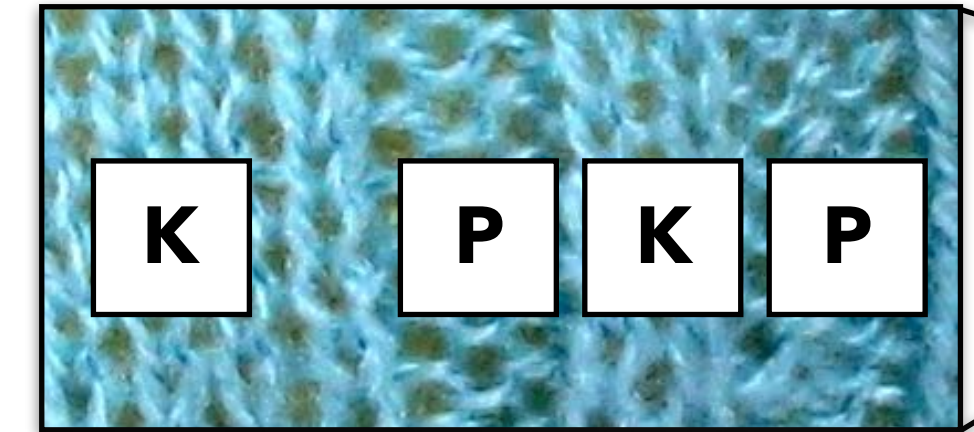
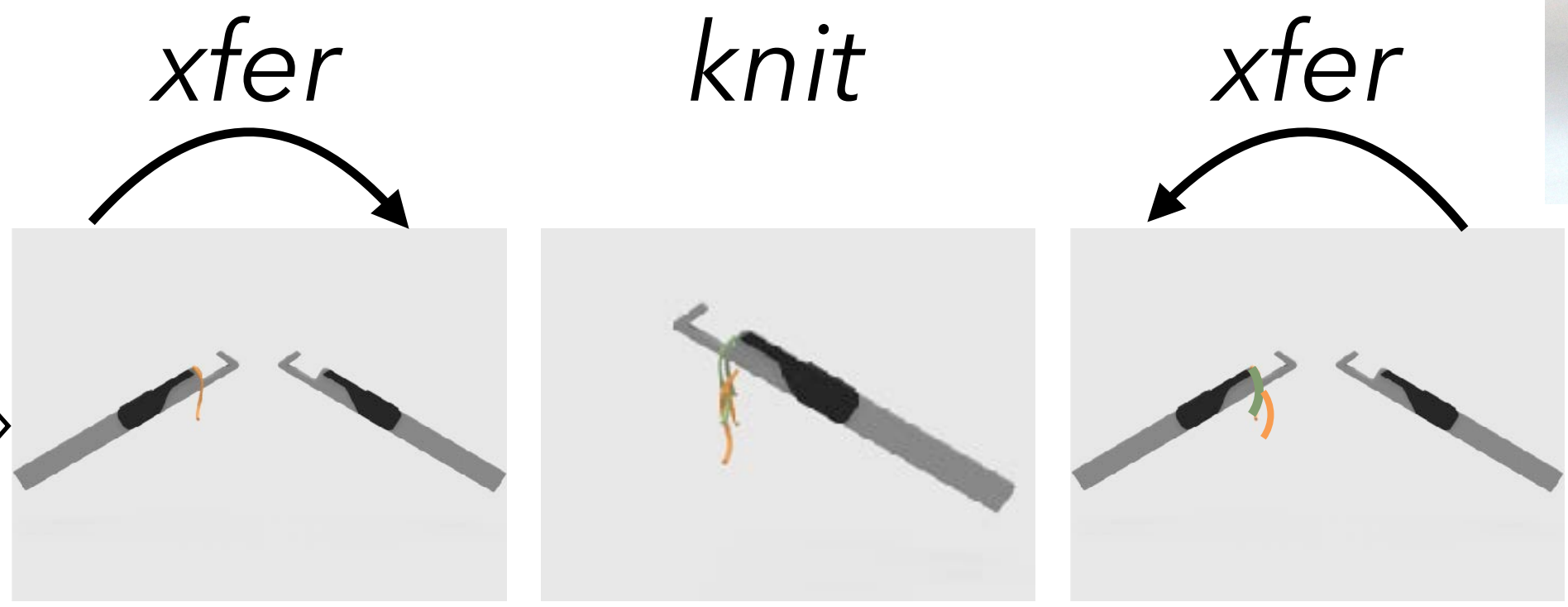

# Augmented Stitch Mesh

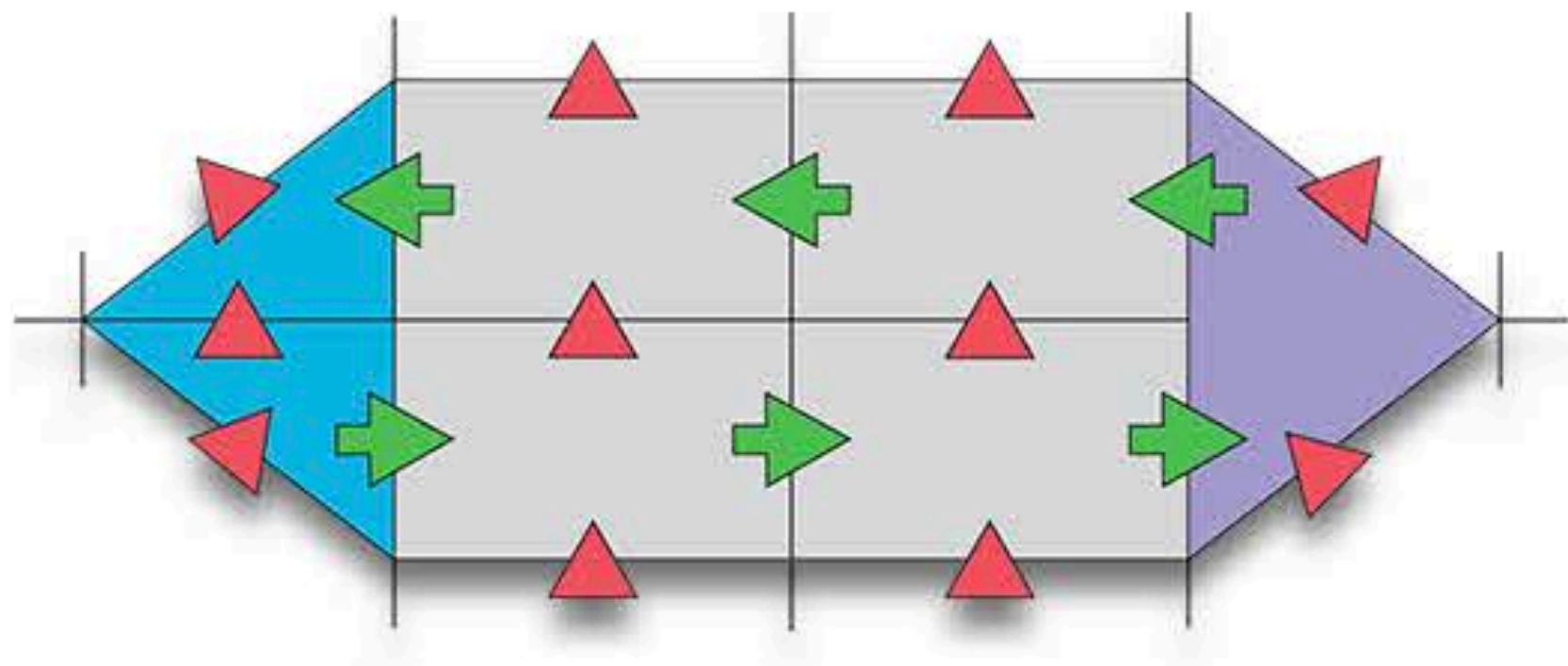

Augmented Stitch Mesh

=

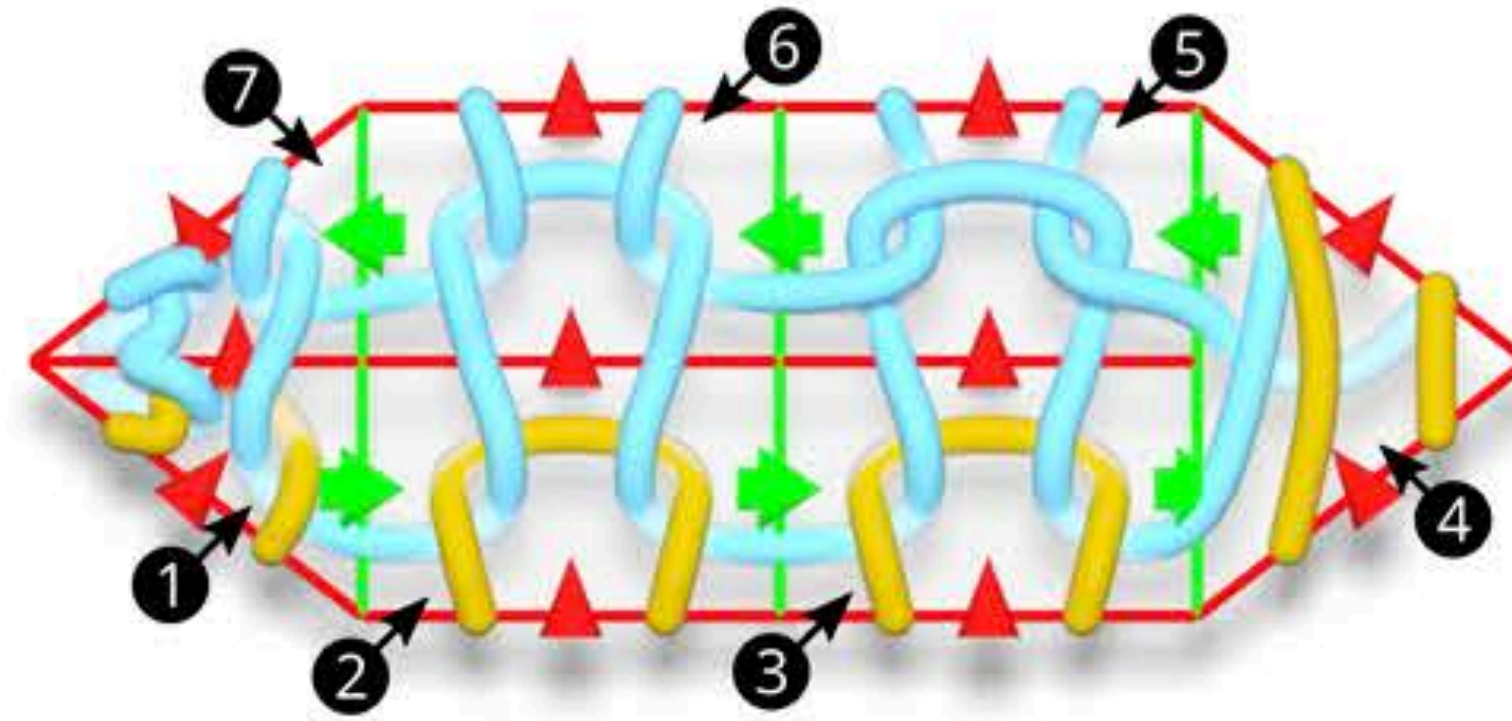

Dependency

+

①	{	in A
	{	knit + f1 A
②	{	knit + f2 A
③	{	knit + f3 A
④	{	tuck + f4 A
⑤	{	xfer f3 b3
	{	knit - b3 A
⑥	{	knit - f2 A
⑦	{	knit - f1 A
	{	out A
	{	xfer b3 f3

Knitting Program

# Visual Knitting Machine Programming

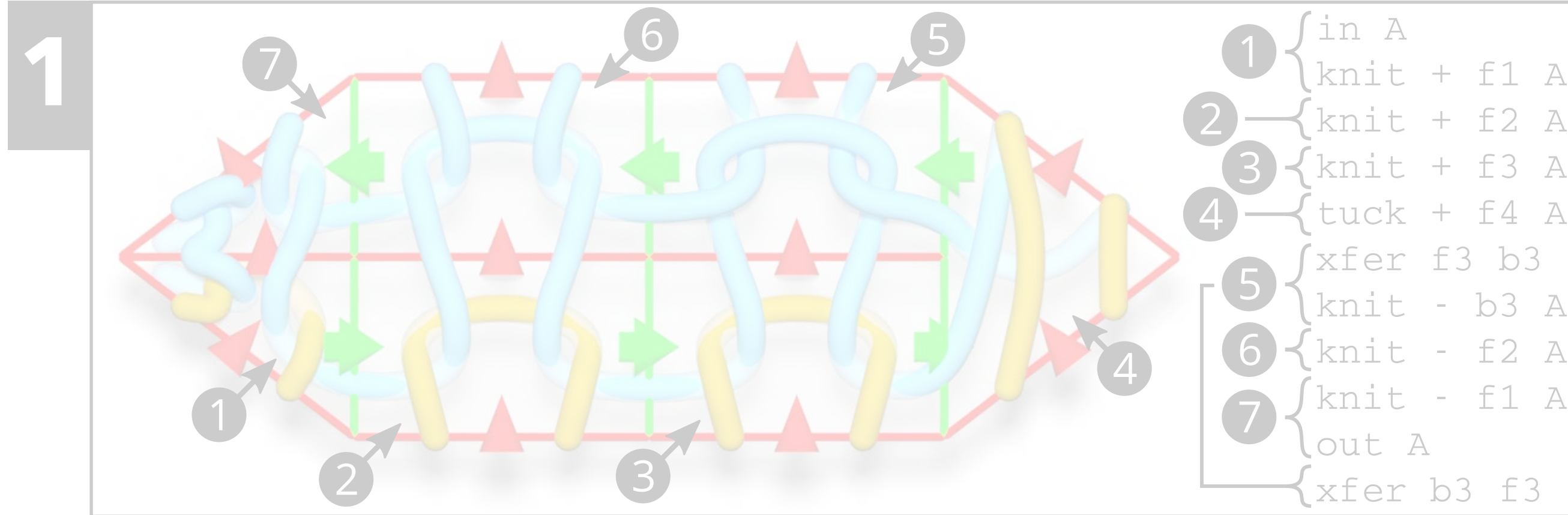

Augmented Stitch Mesh Representation



Results

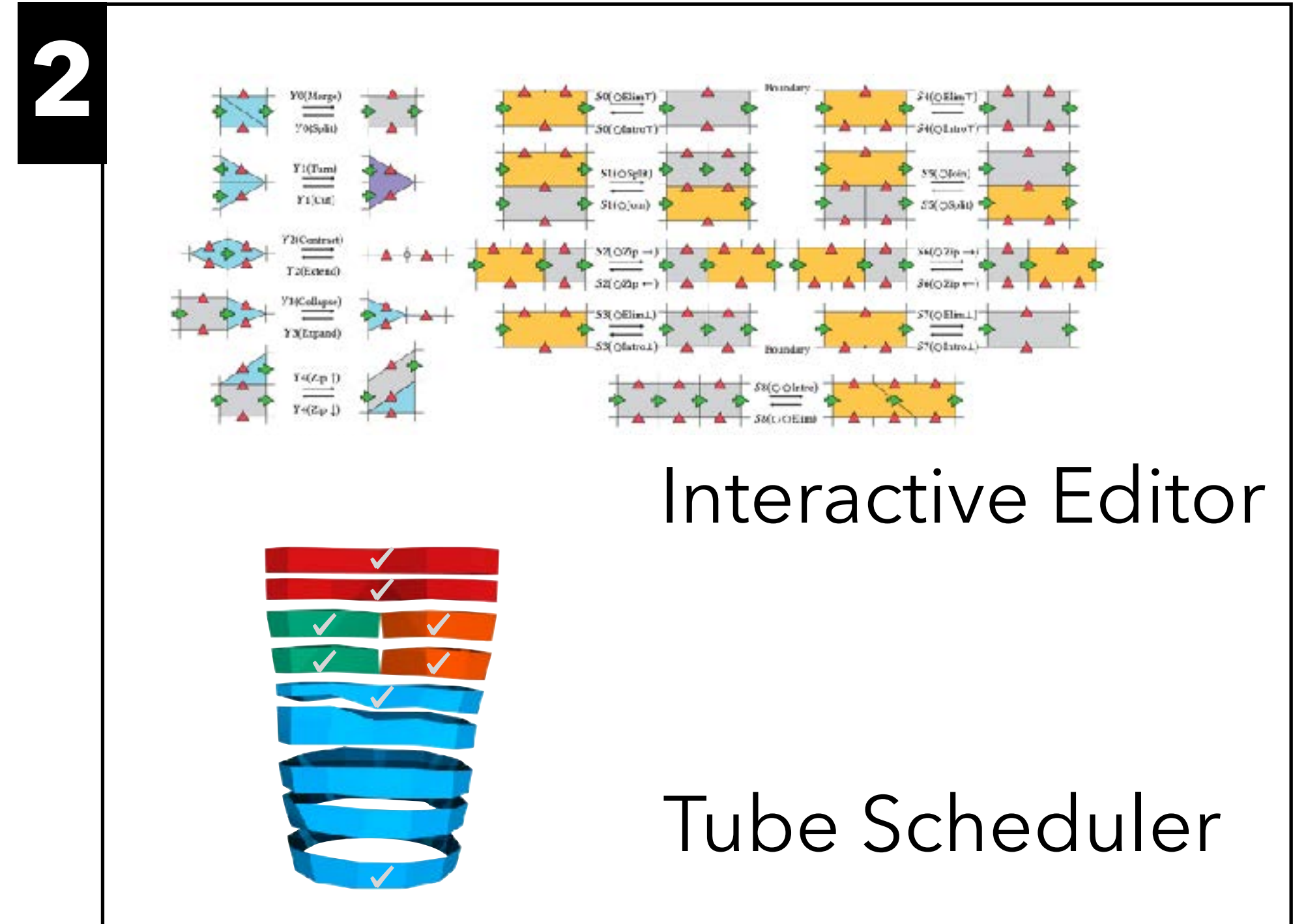

System

# Pipeline of our design system

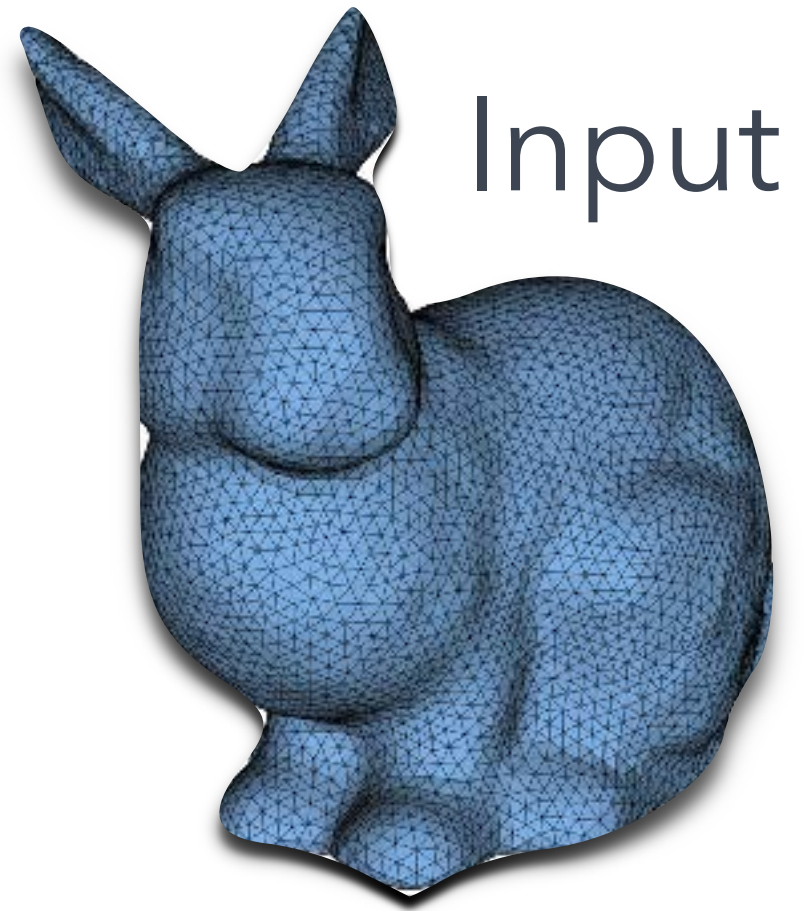

Input

# Pipeline of our design system

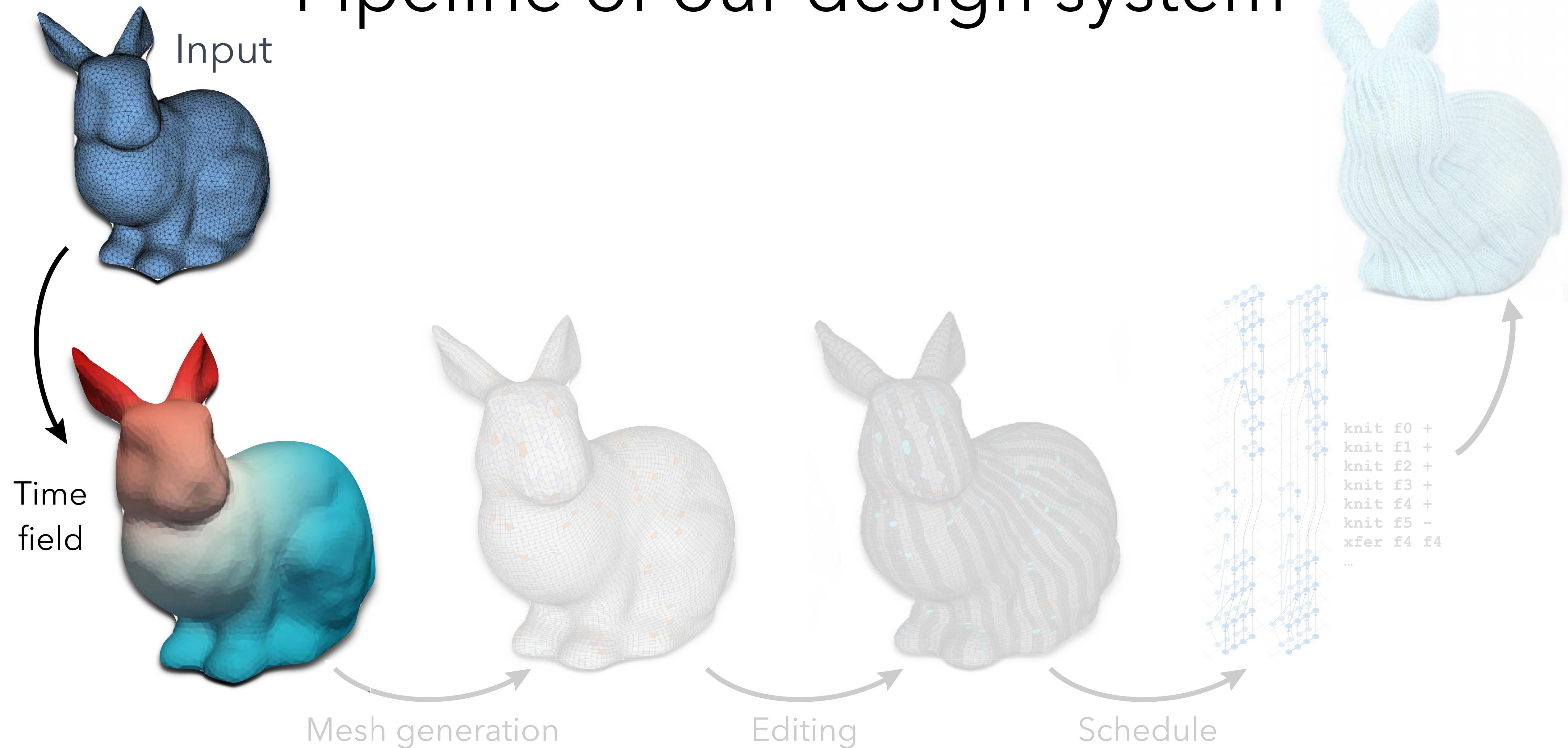

# Knitting time function

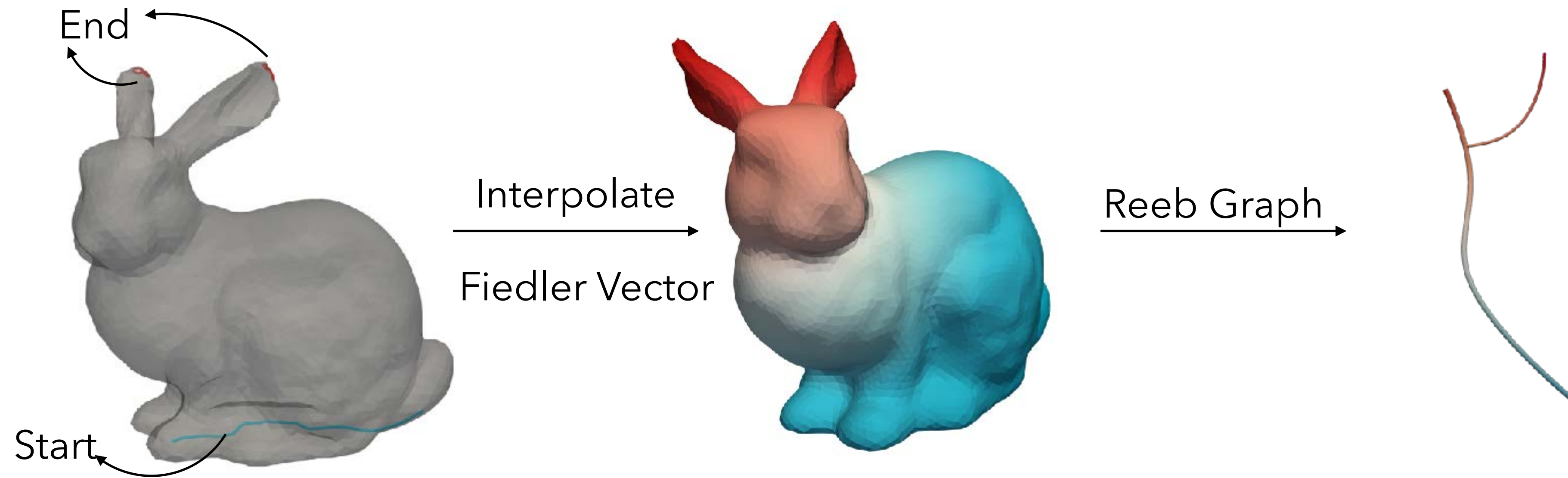

A scalar function over the mesh  
that defines knitting order

Reeb Graph has an upward  
planar embedding  $\iff$   
machine knittable

[Narayanan et al. '18]



# Pipeline of our design system



# Augmented stitch mesh generation

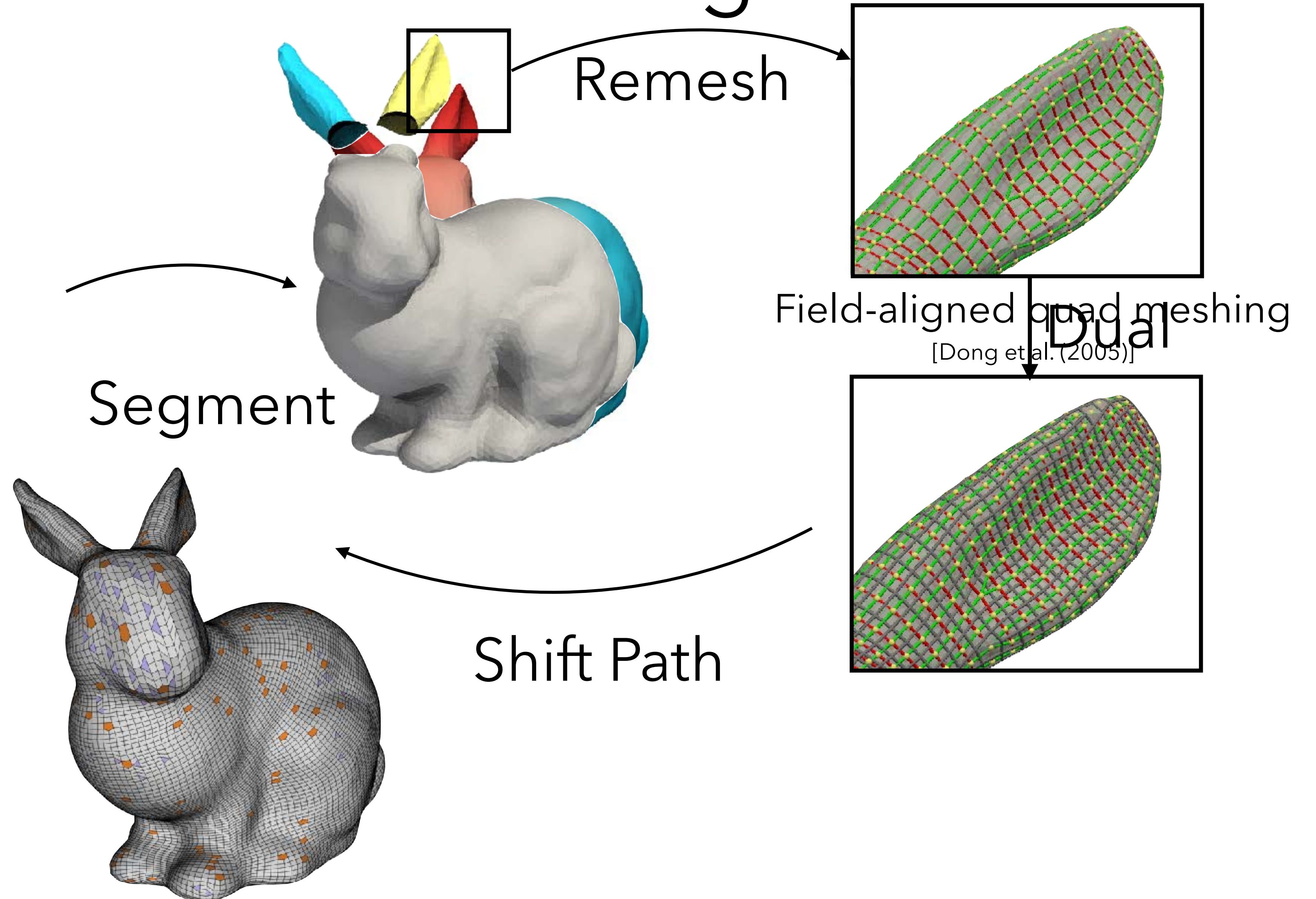

# Pipeline of our design system

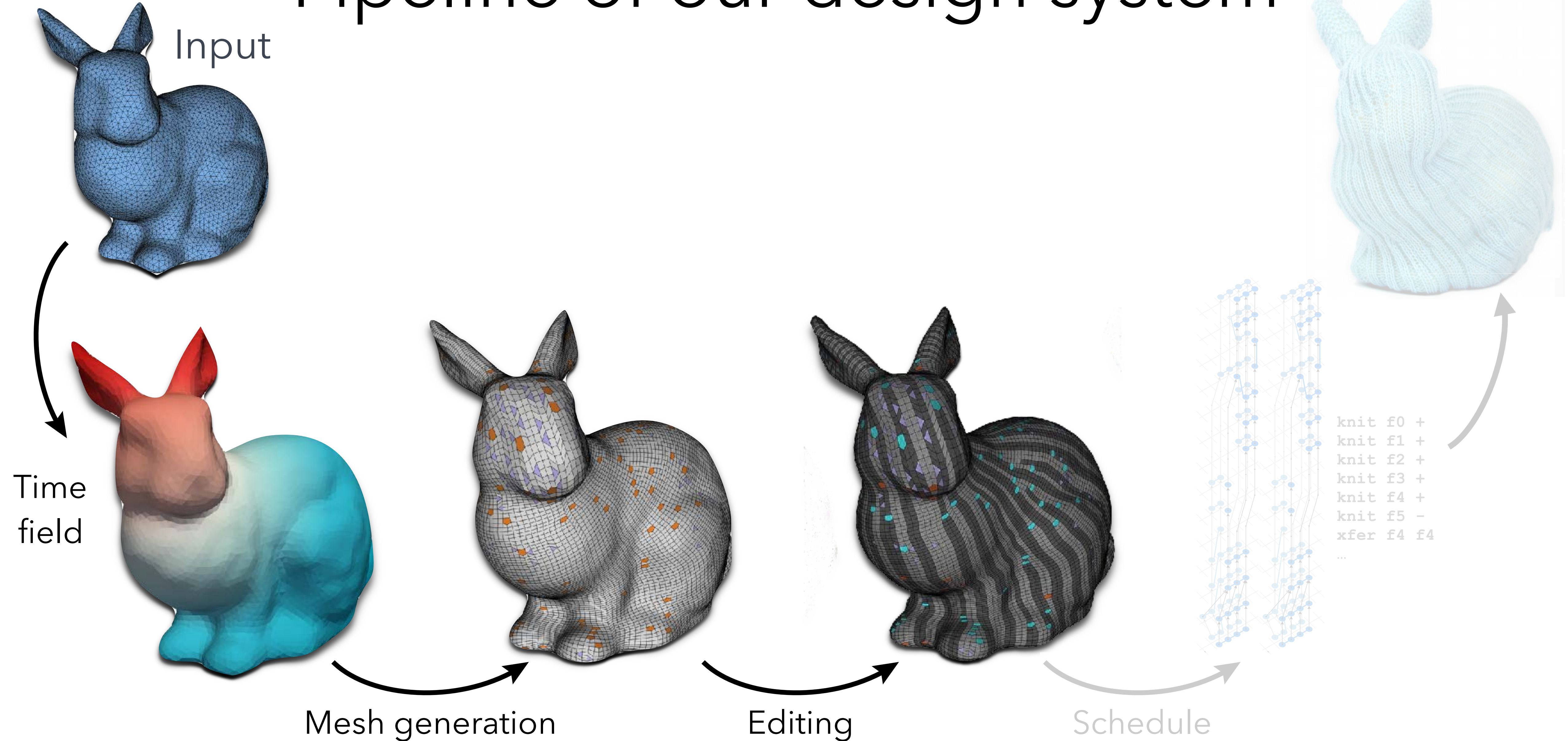

# Yarn Operations

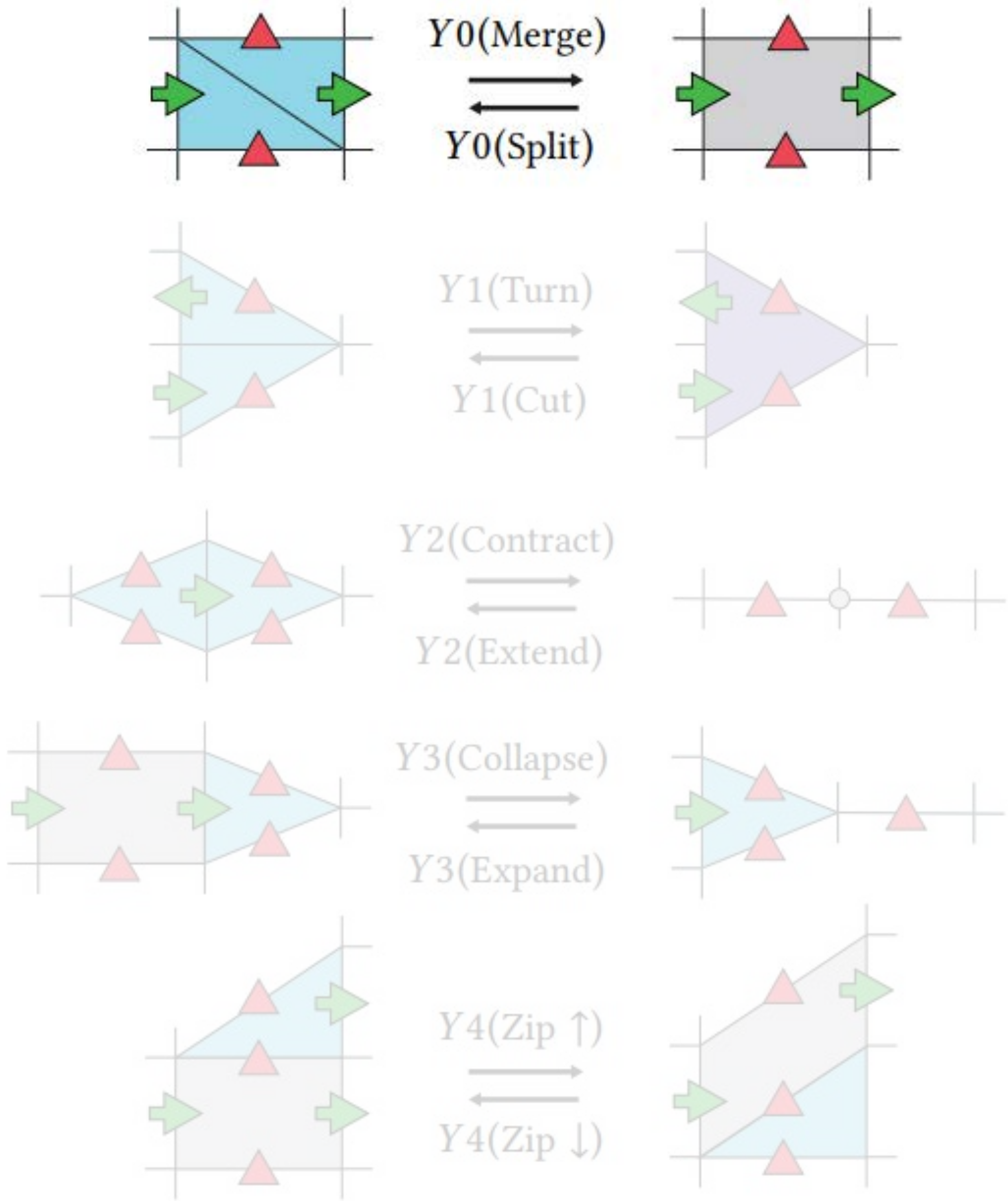

start(N, Y)

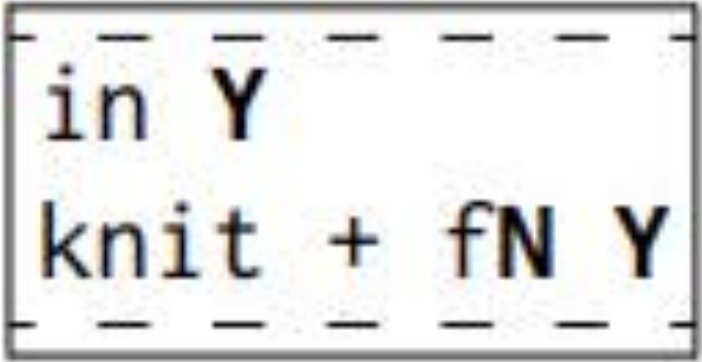

end(N, Y)

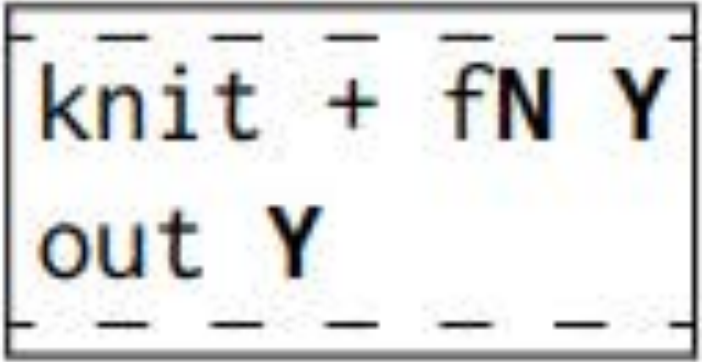

# Yarn Operations

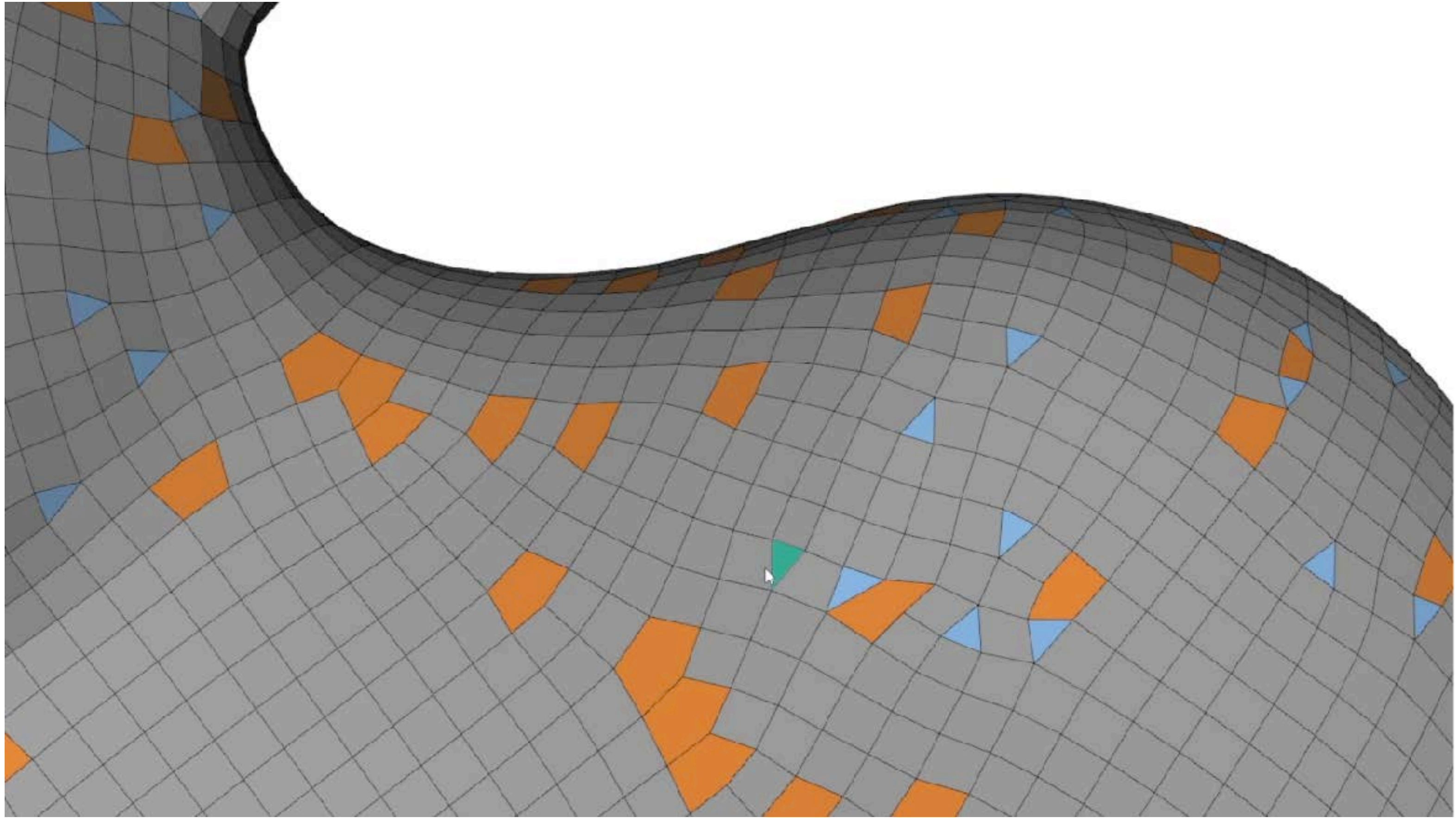
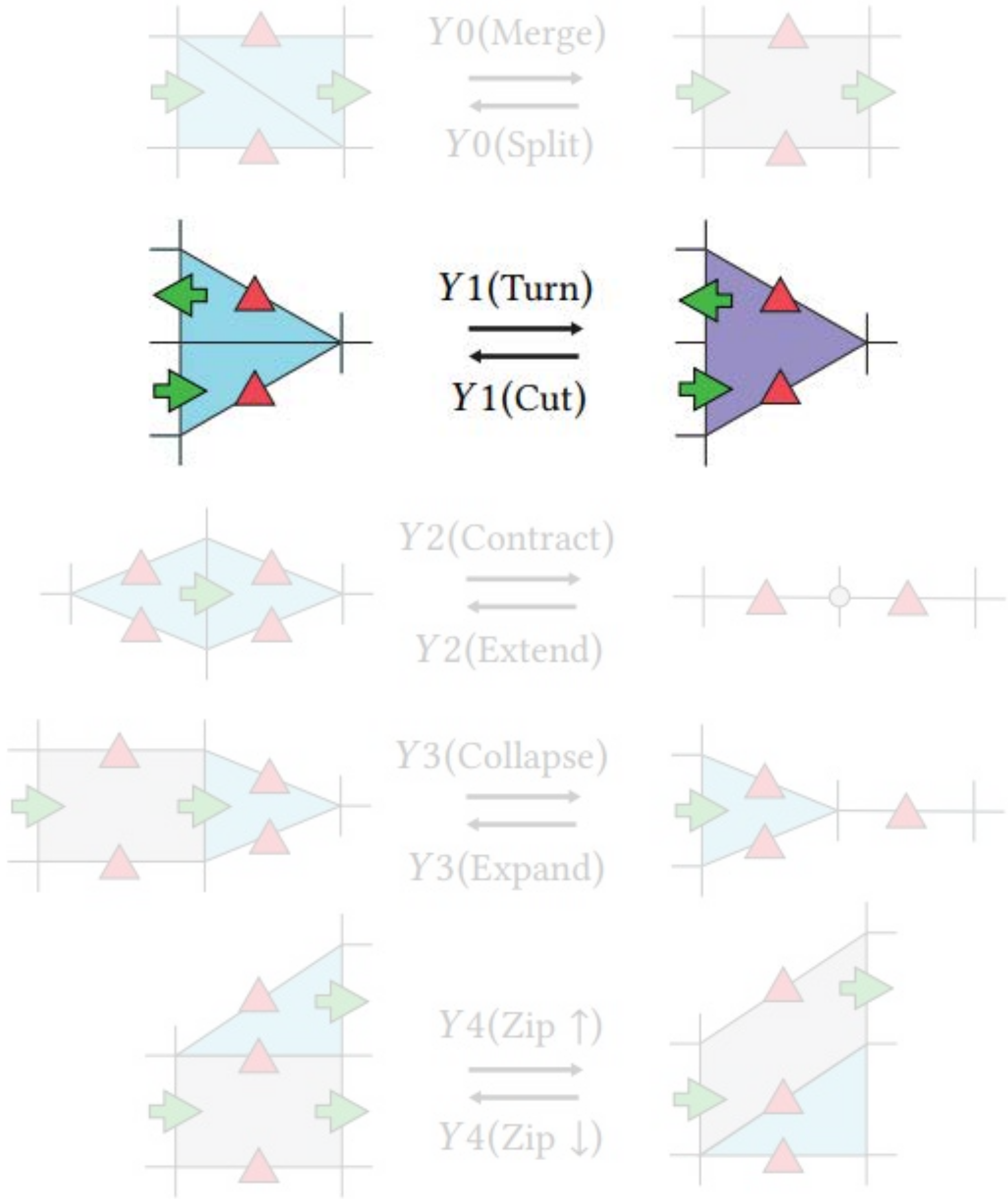

# Yarn Operations

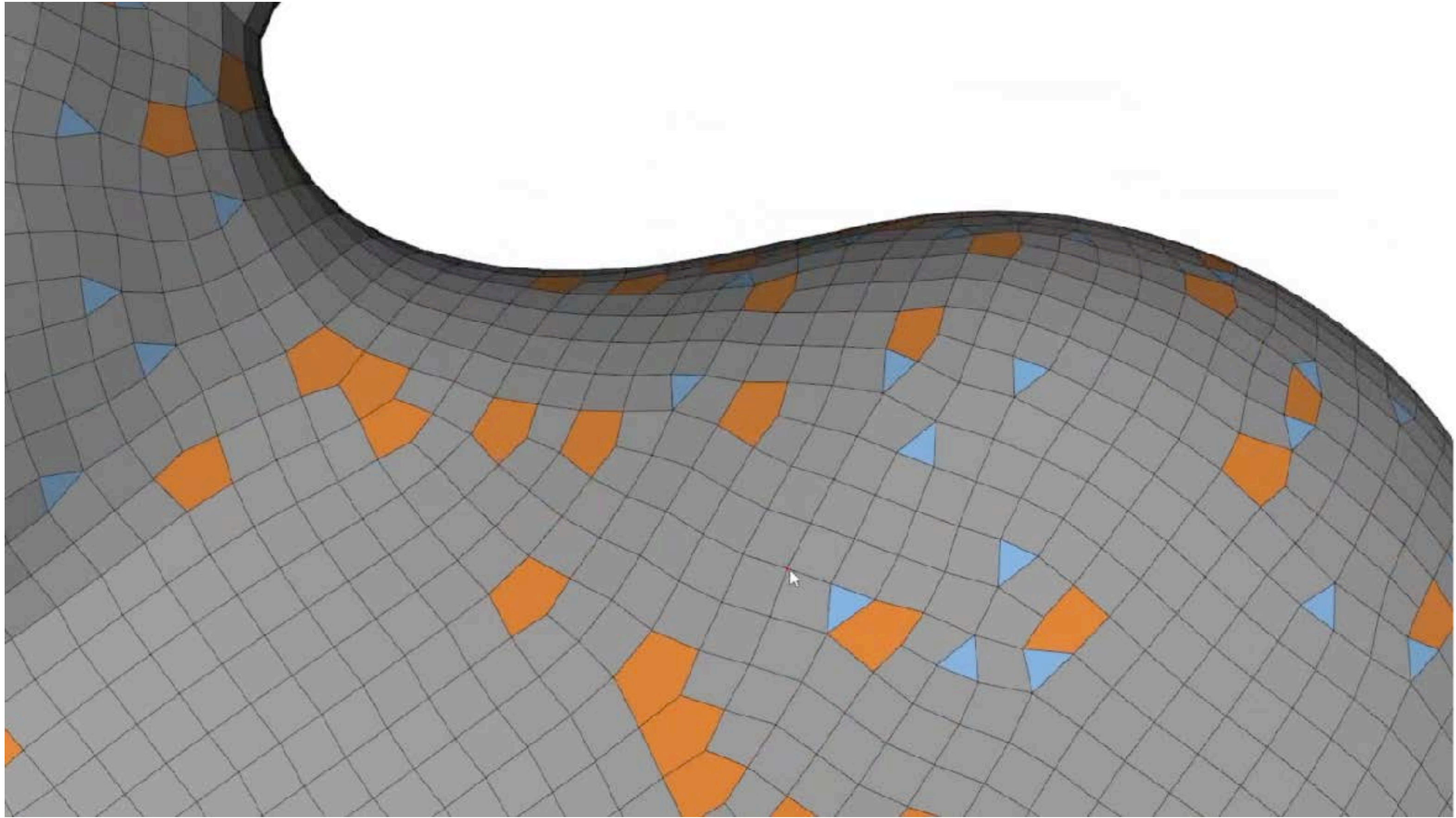
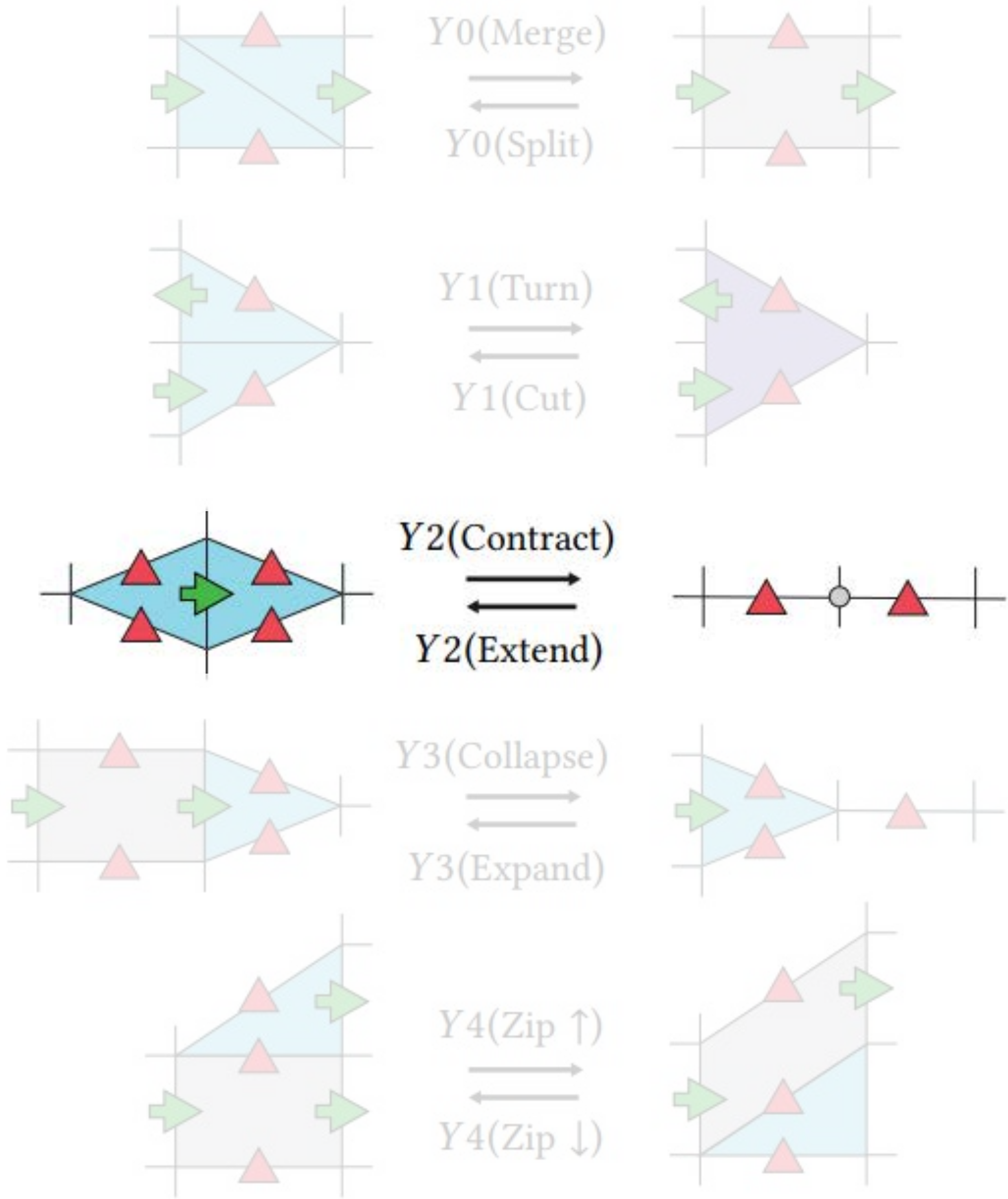

# Yarn Operations

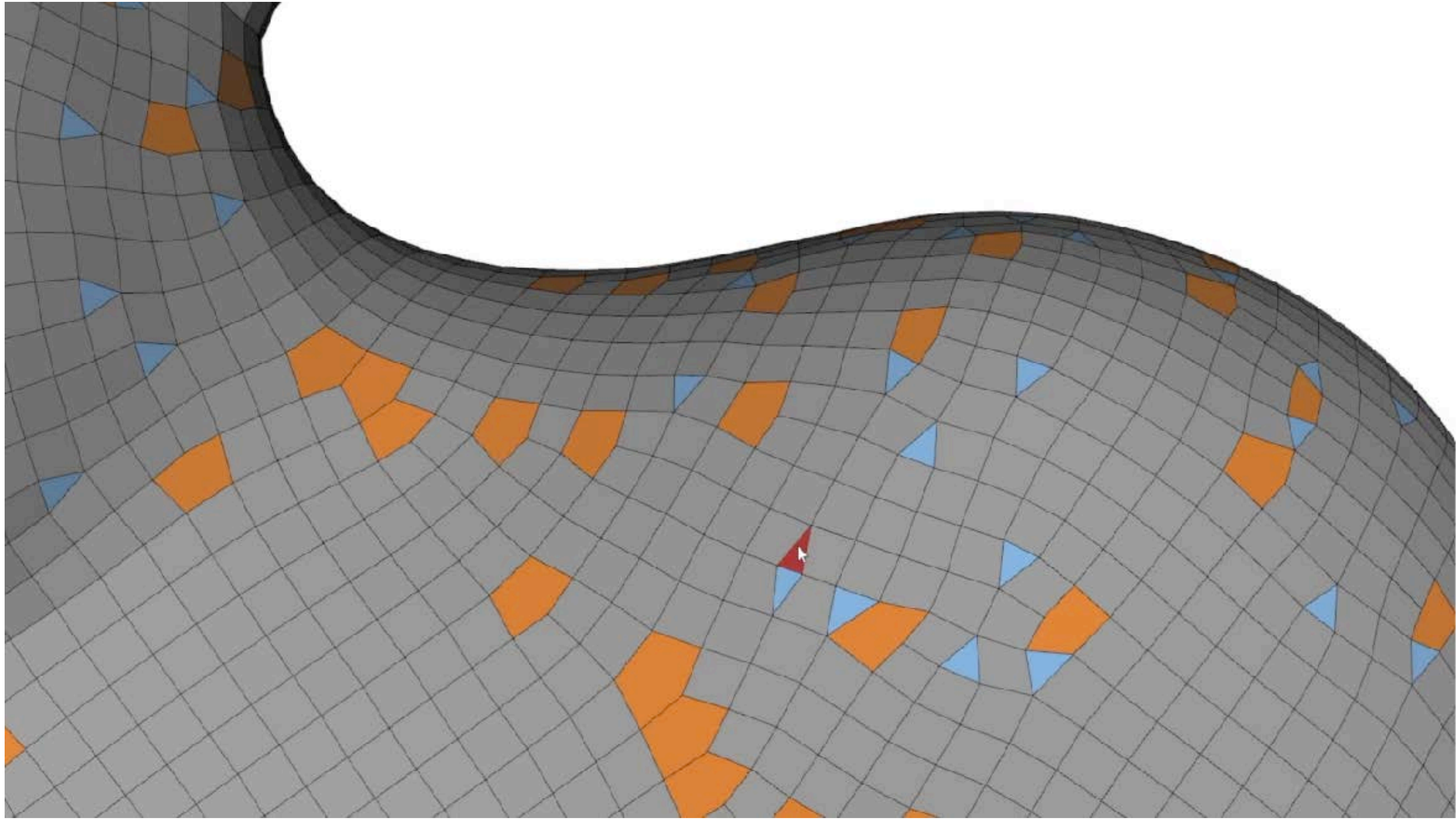
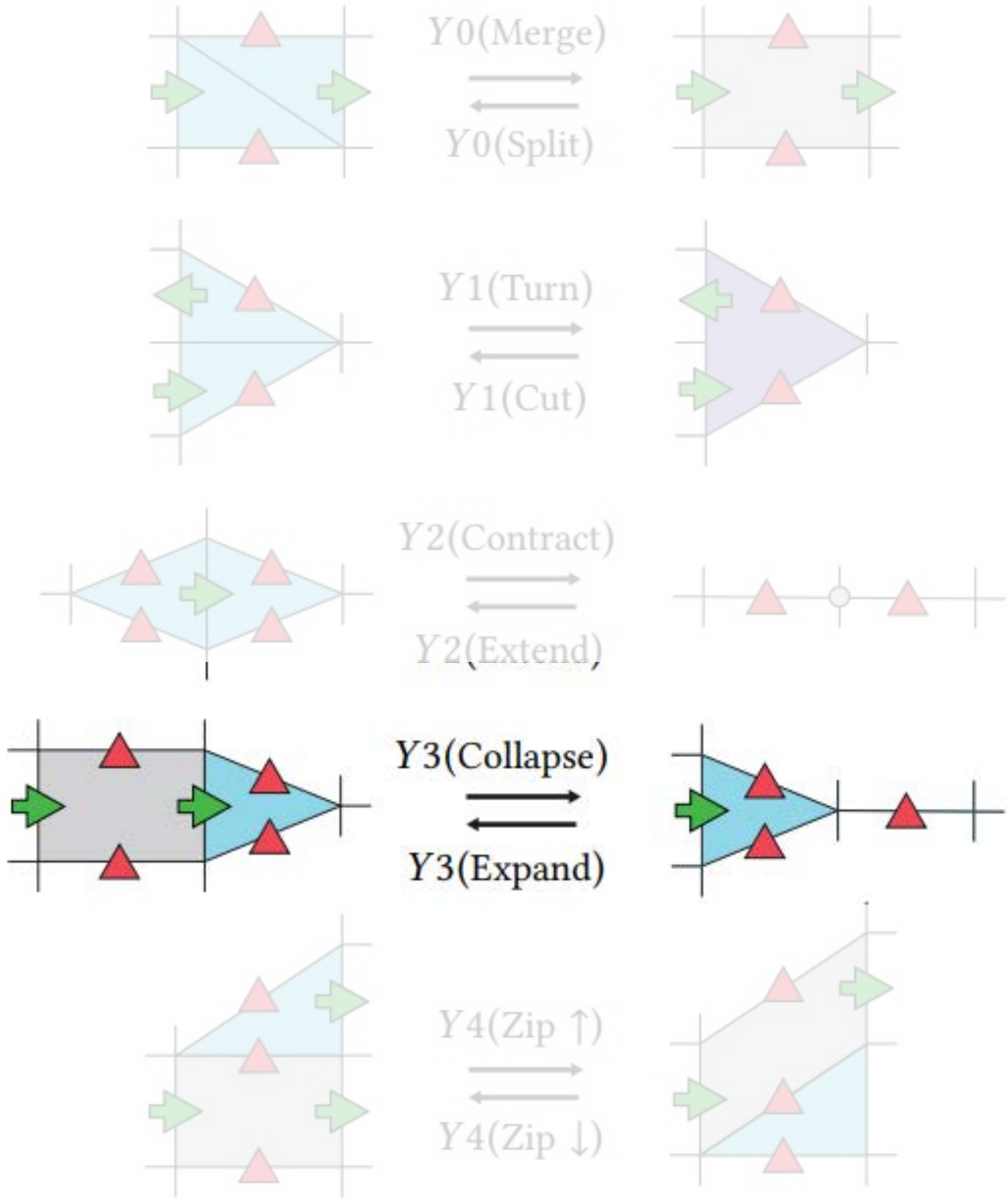

Similar to [Peng et al. 13] for connectivity editing

# Yarn Operations

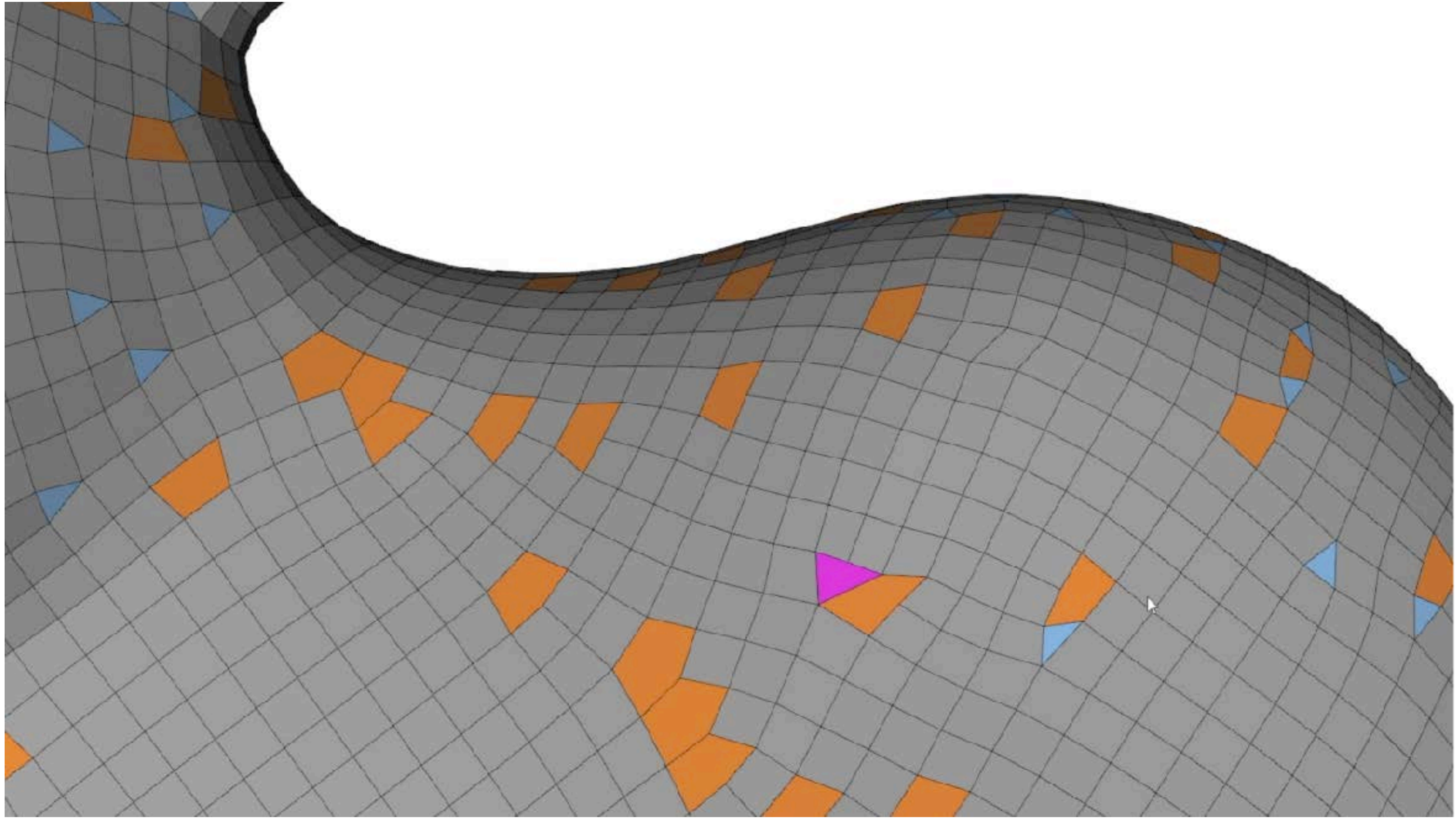
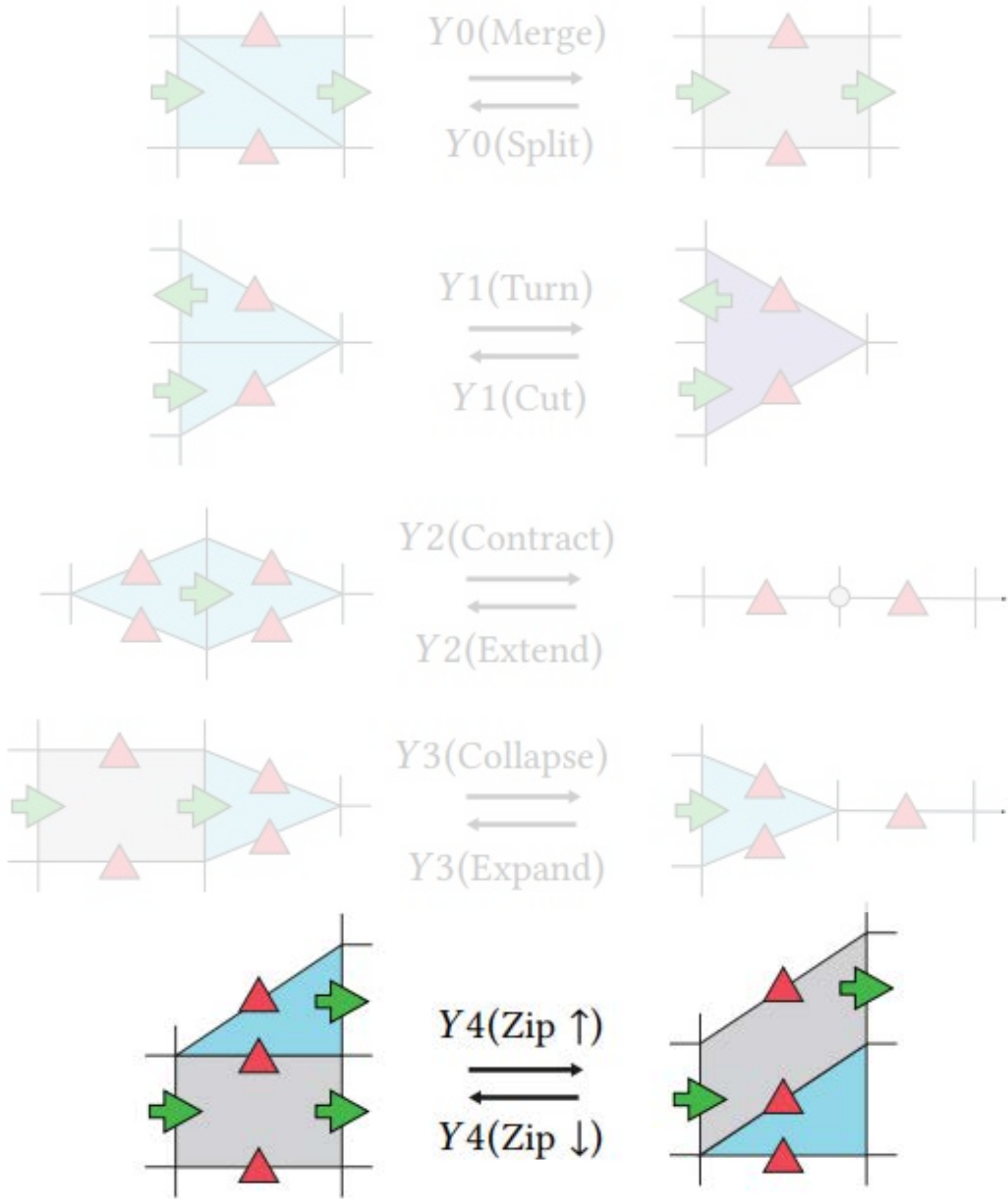



# Yarn Operations

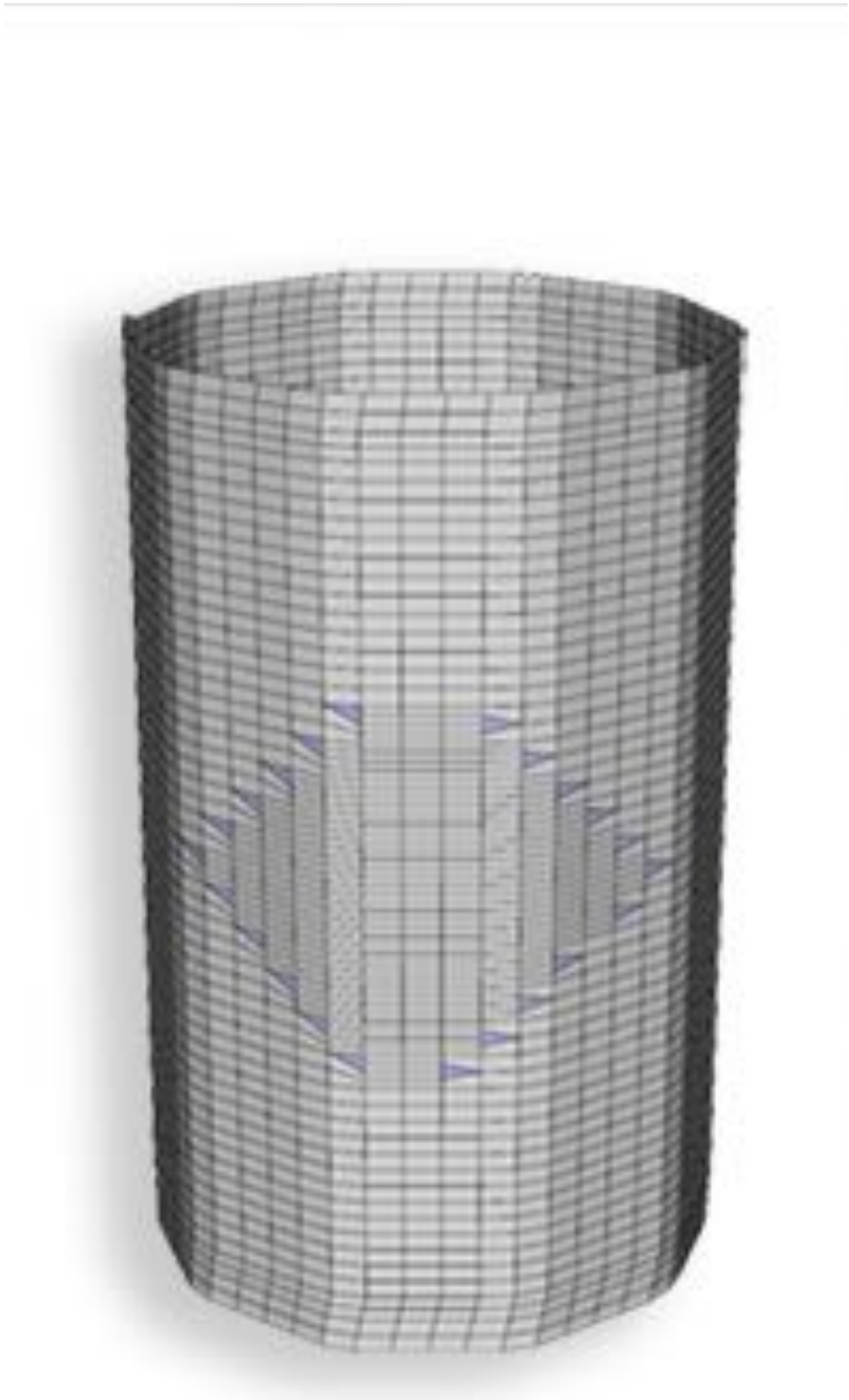
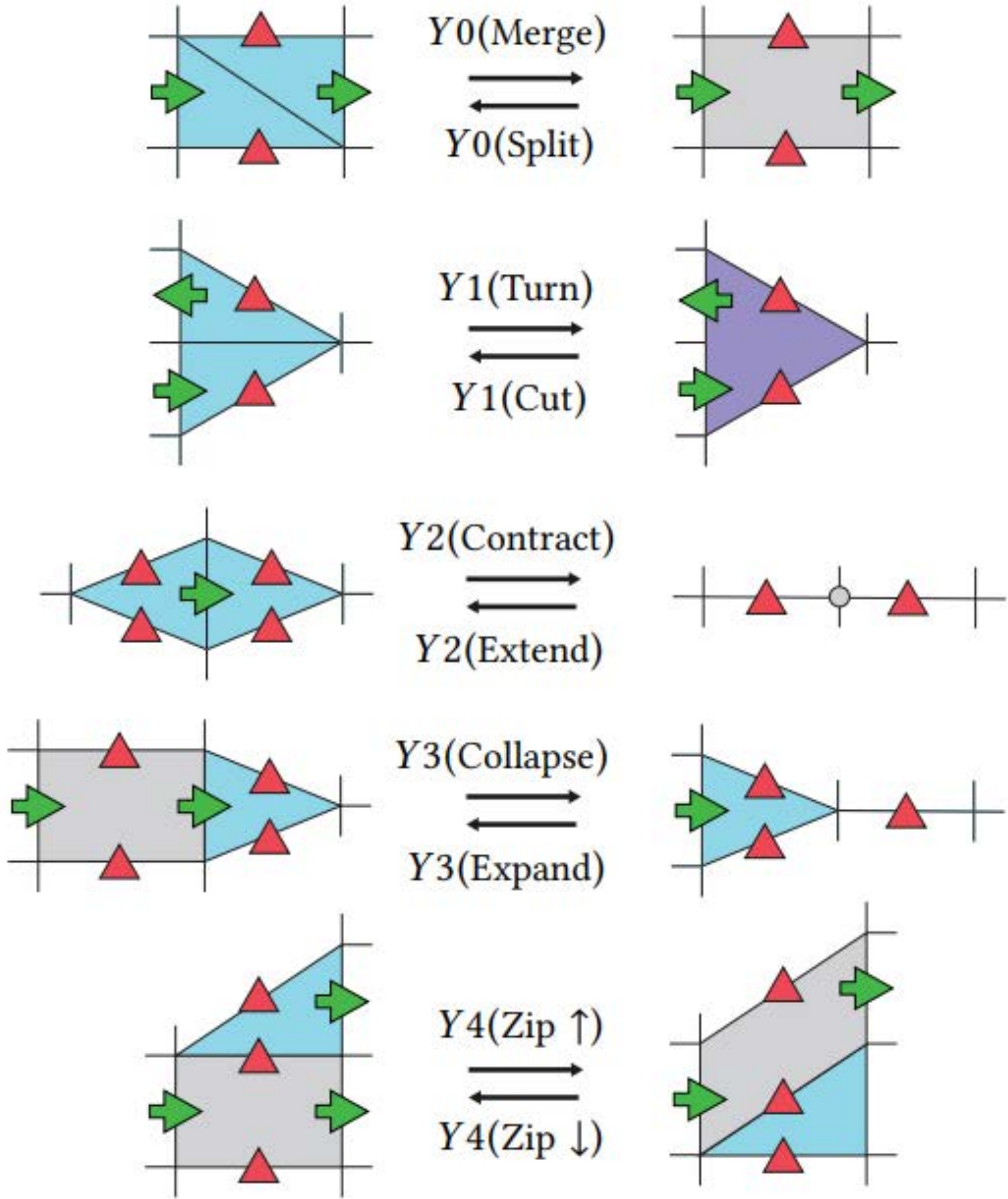

# Shape Operations

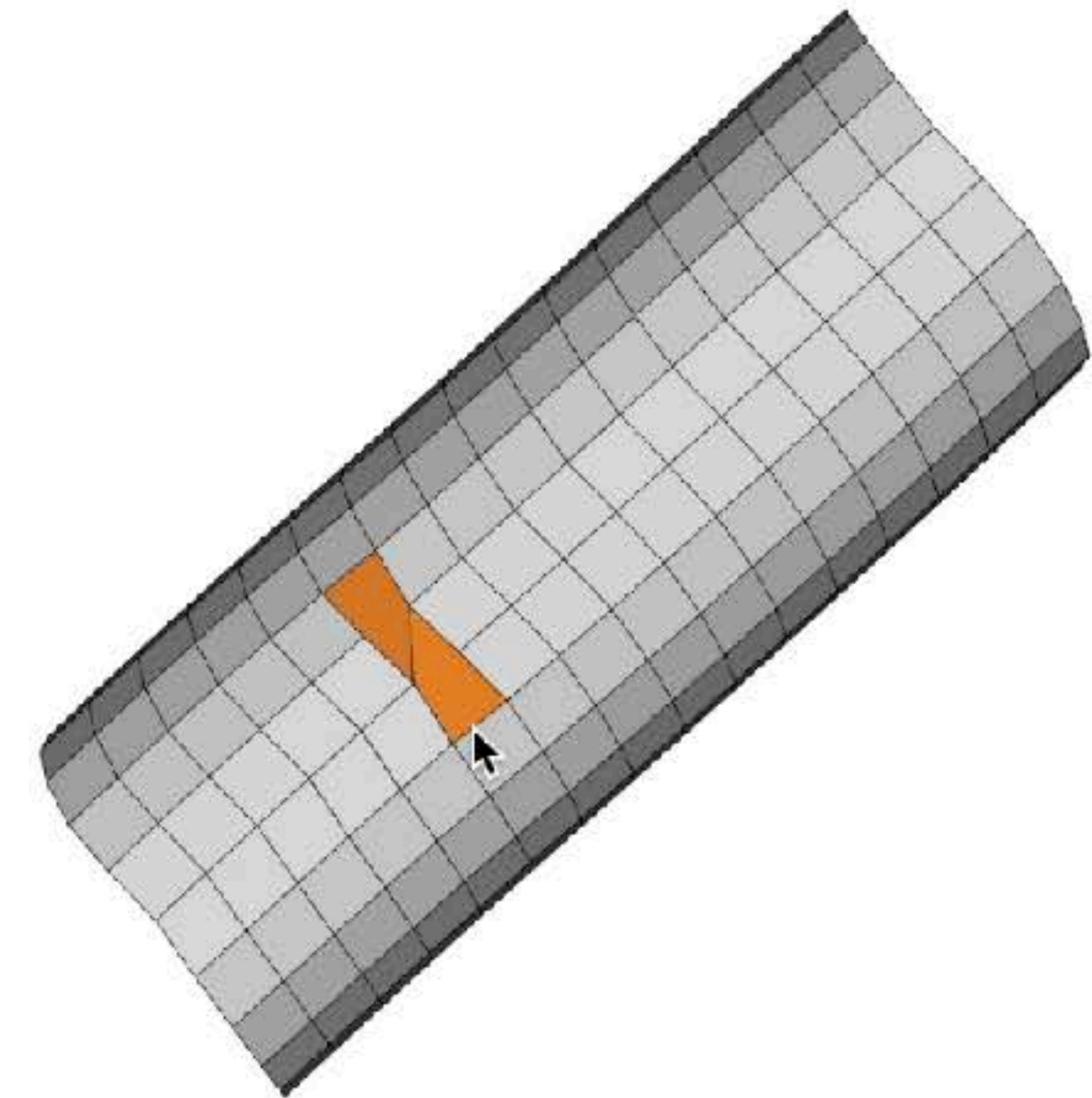
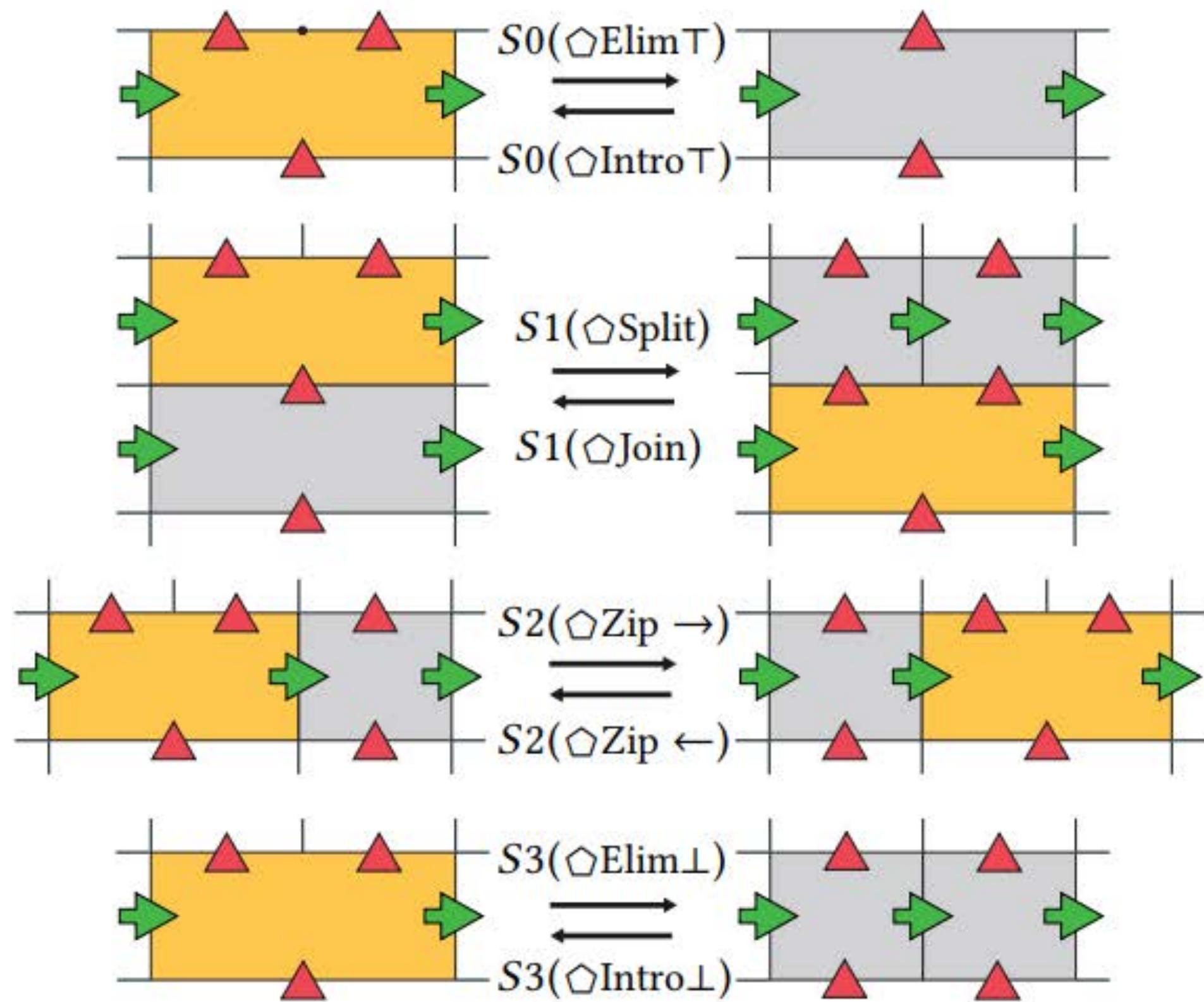

# Shape Operations

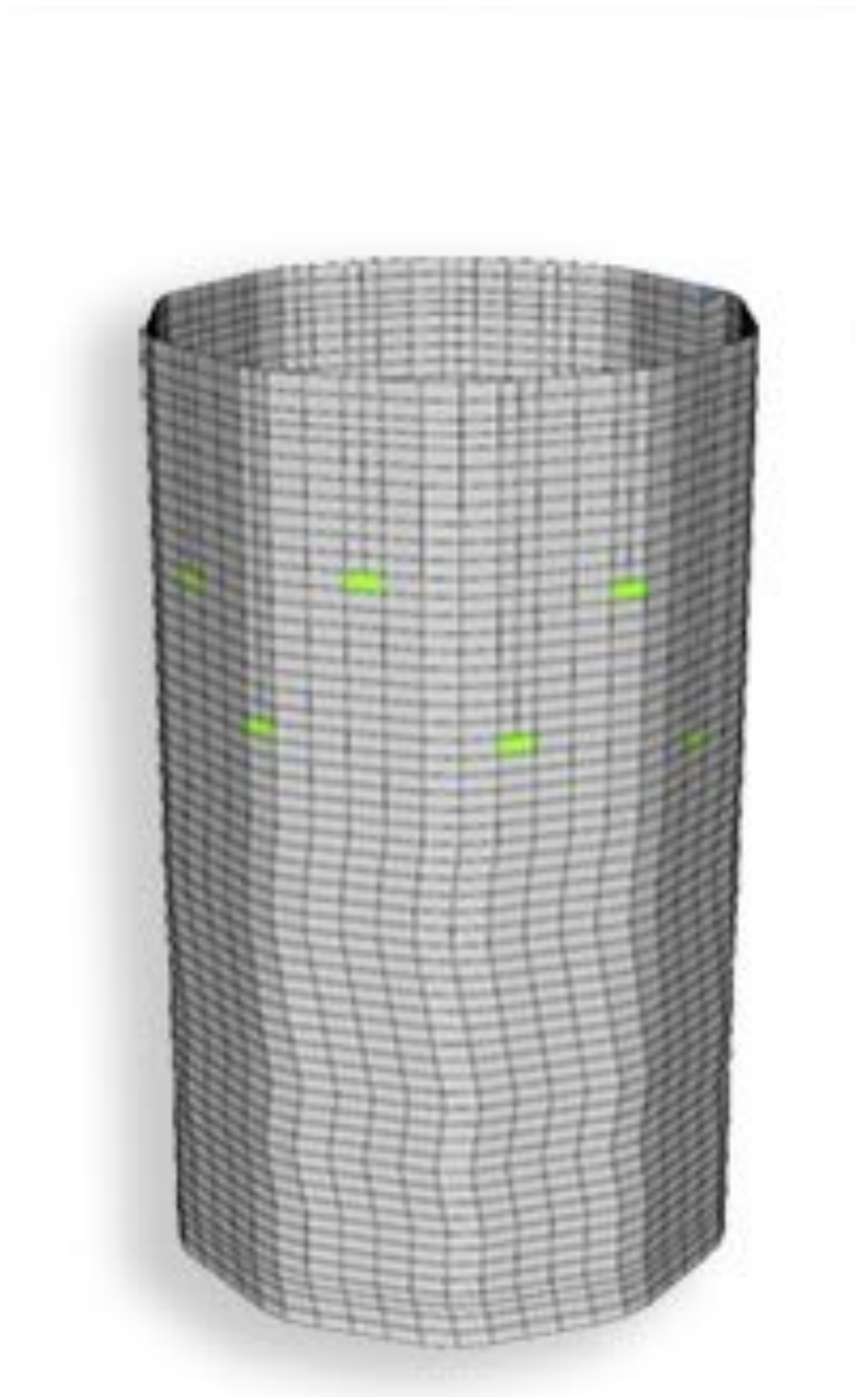
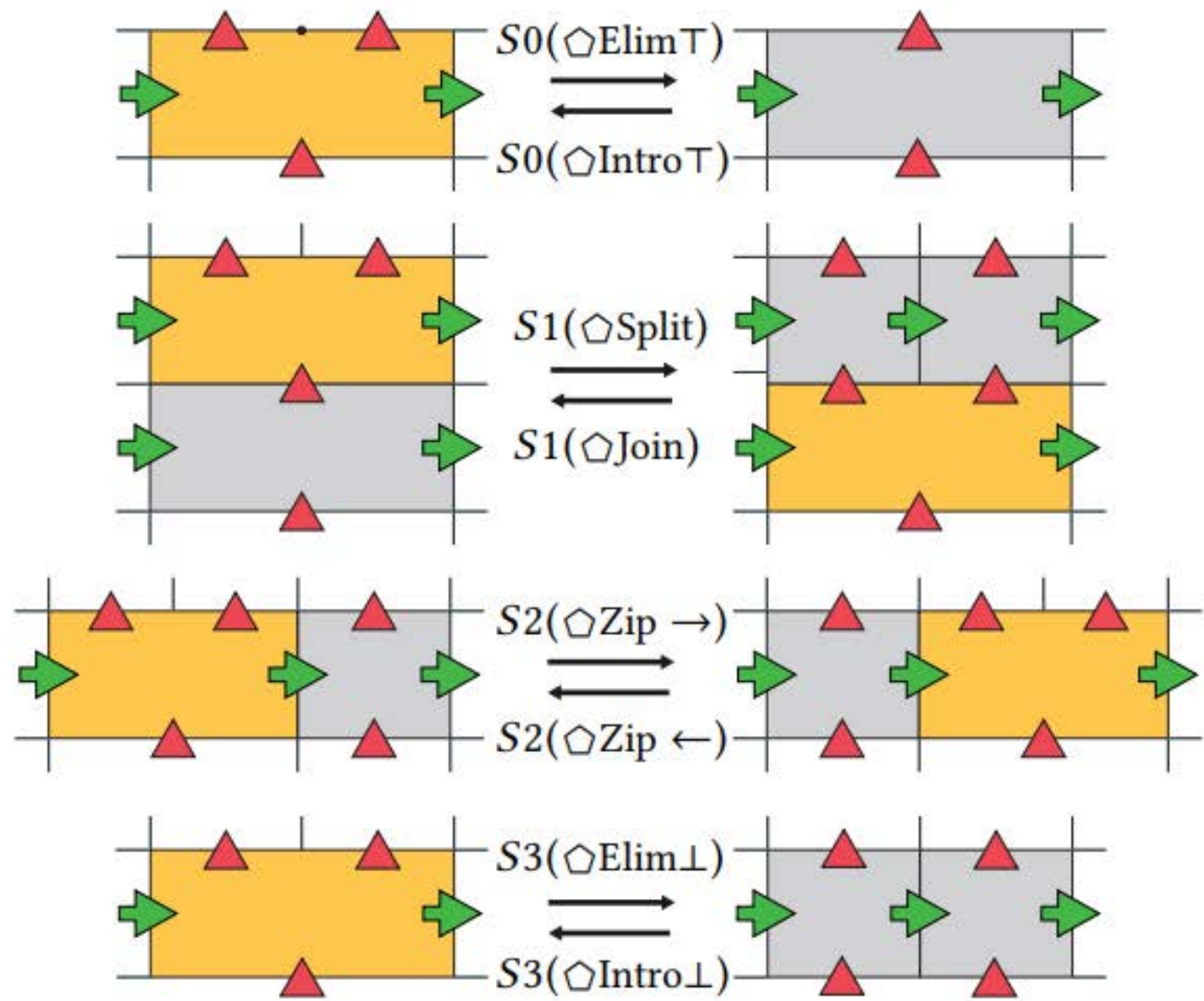

# Type Operations

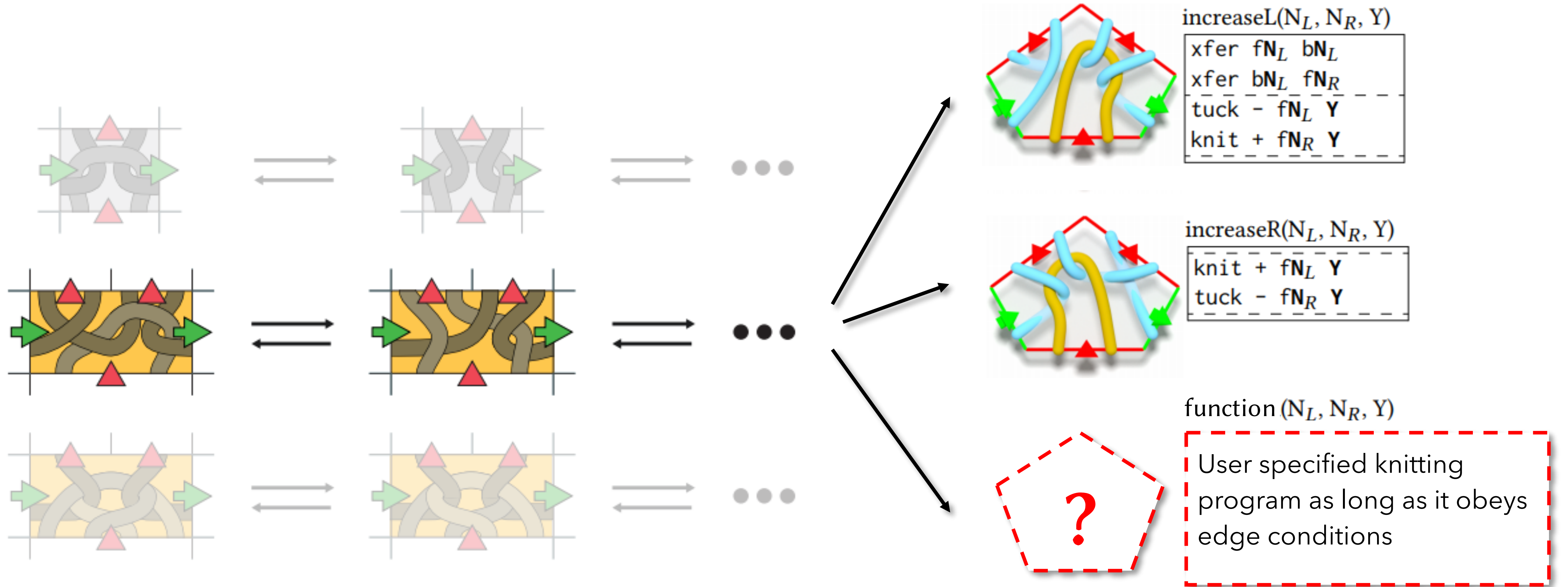

# Cable Face Types

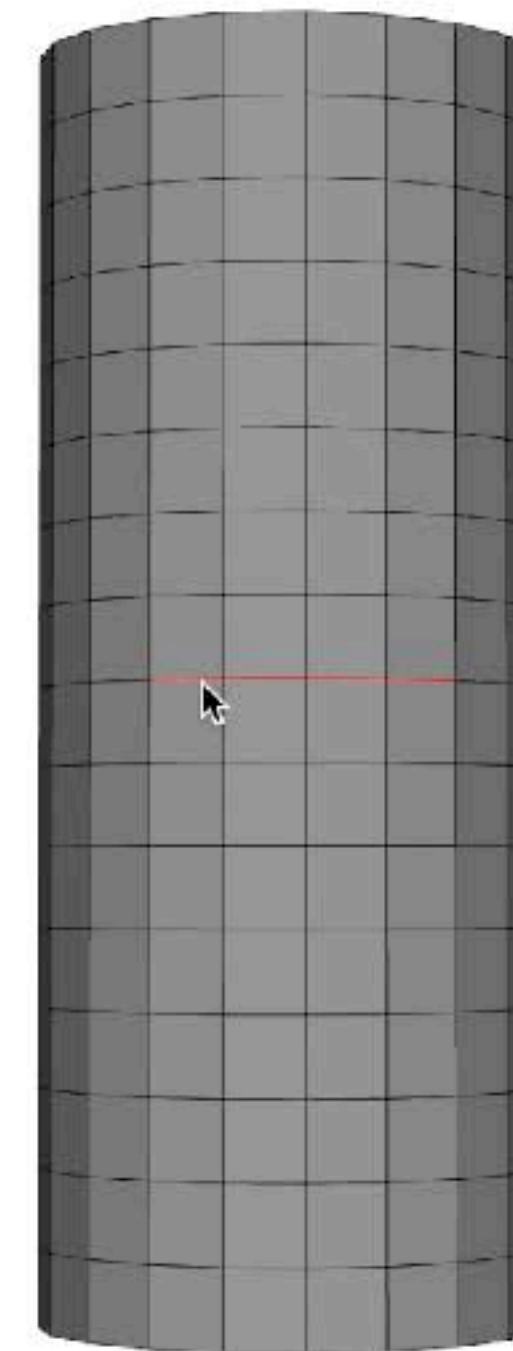
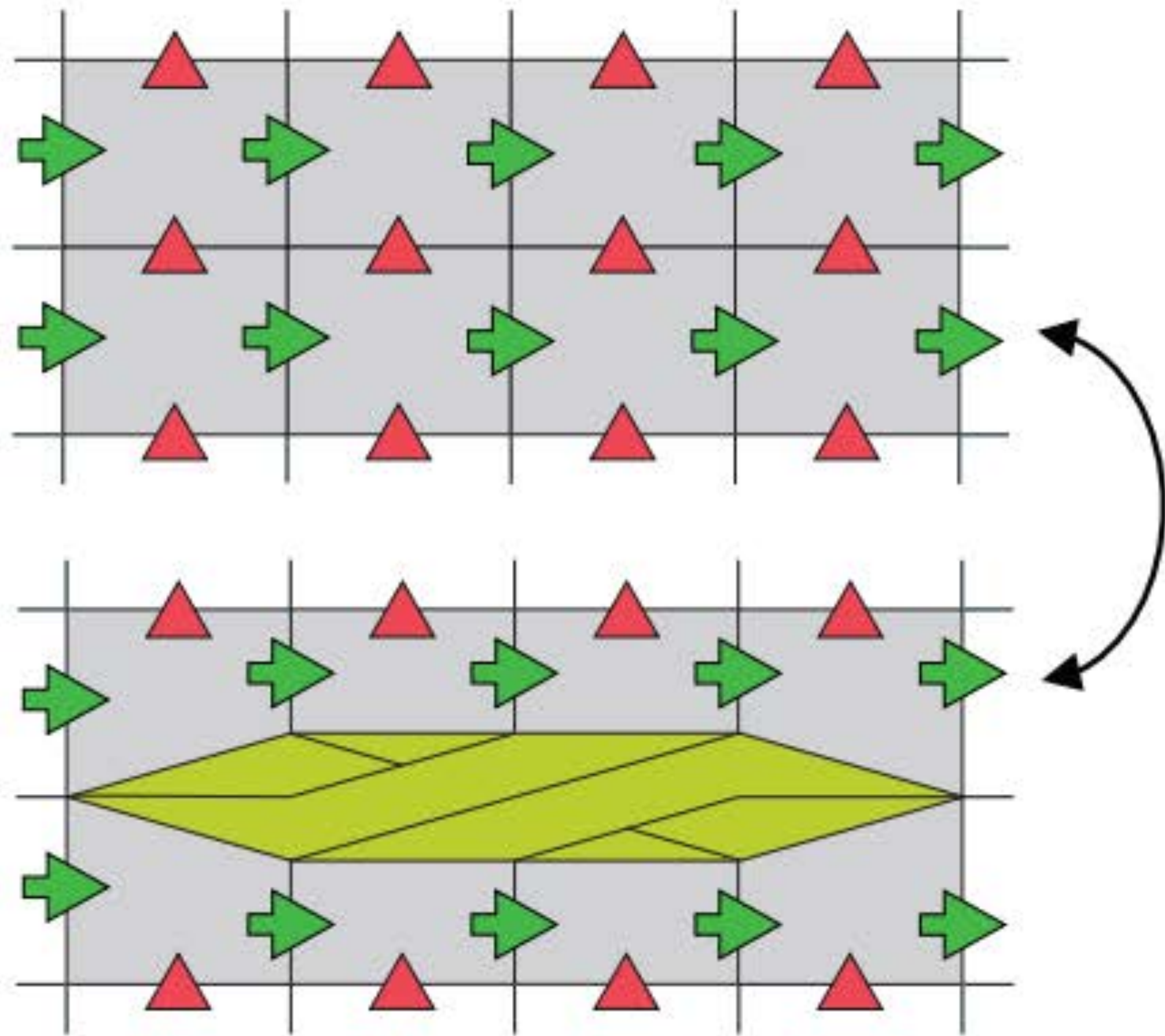

# Cable Face Types

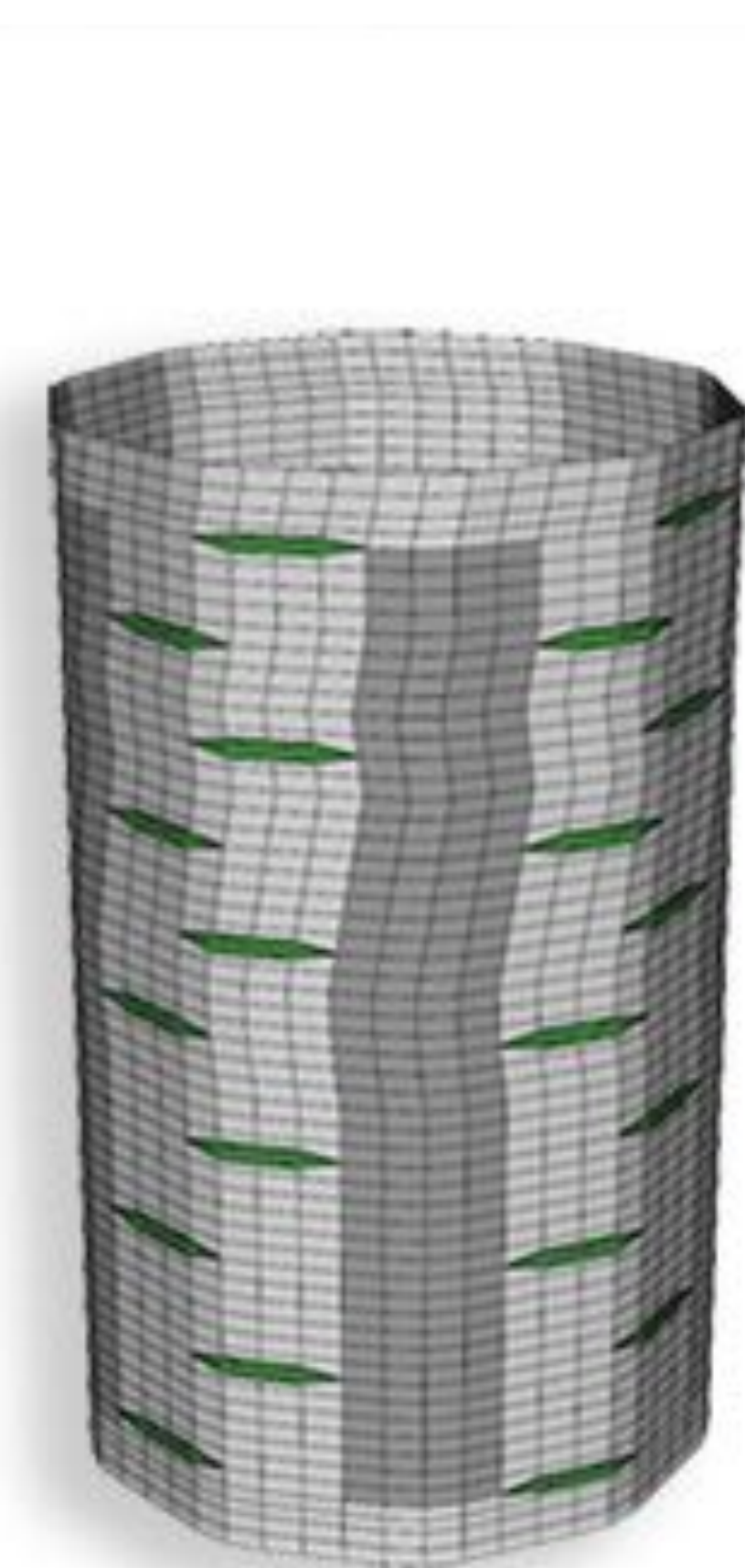
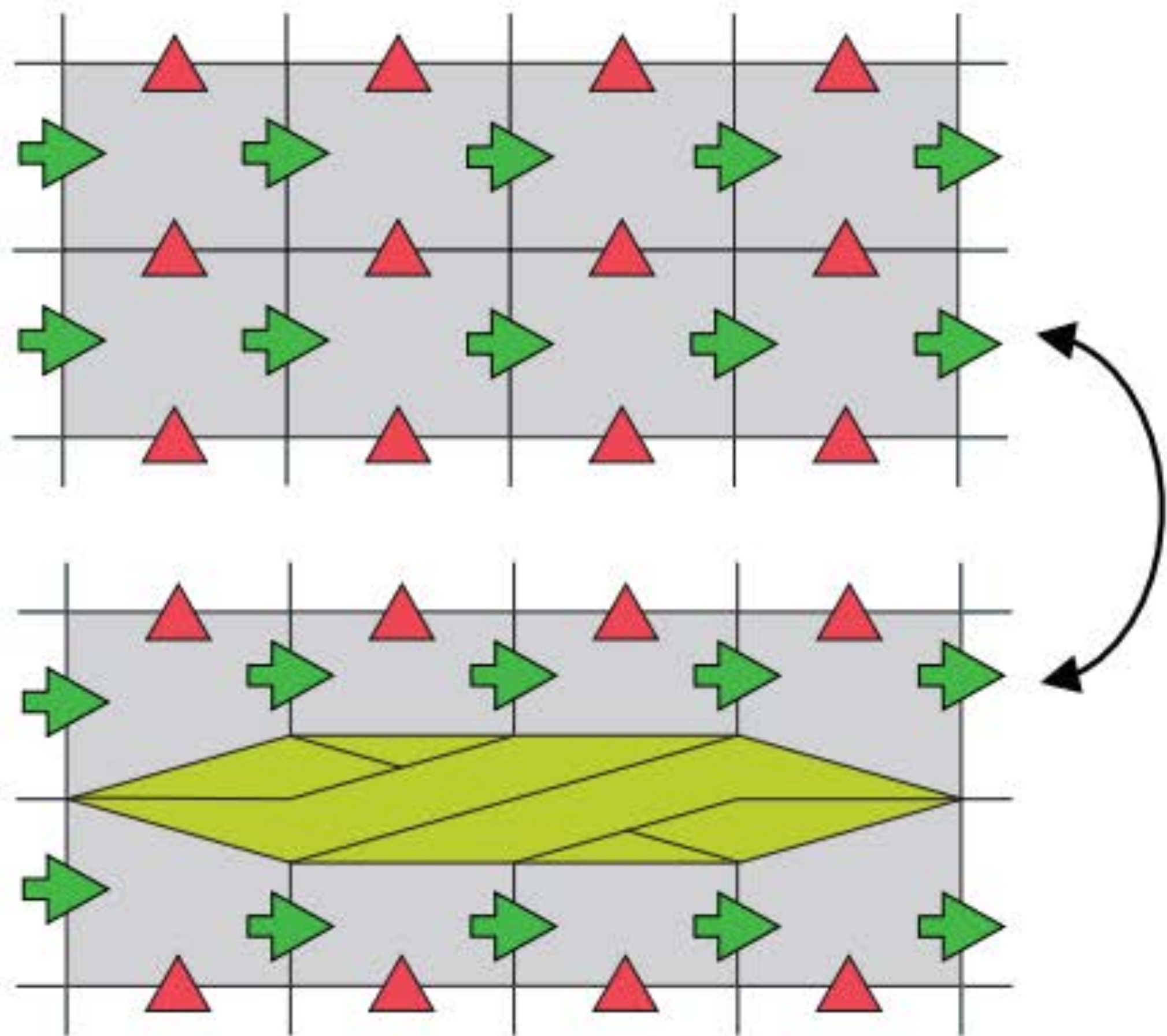

# Augmented stitch mesh editing

Mesh must remain directed acyclic after performing the edit operation.

Edits must agree with existing edge labels and direction

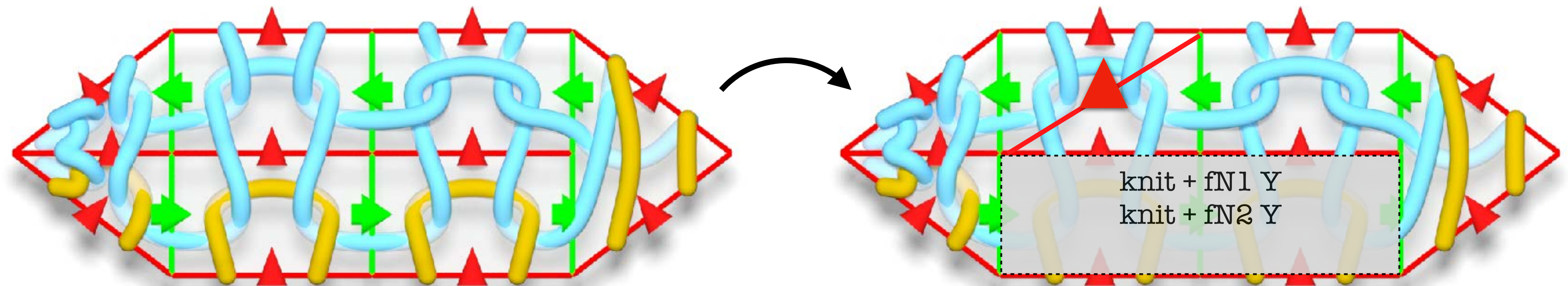

# Valid operations maintain directed acyclic property

Edit operations can introduce a cyclic dependency.

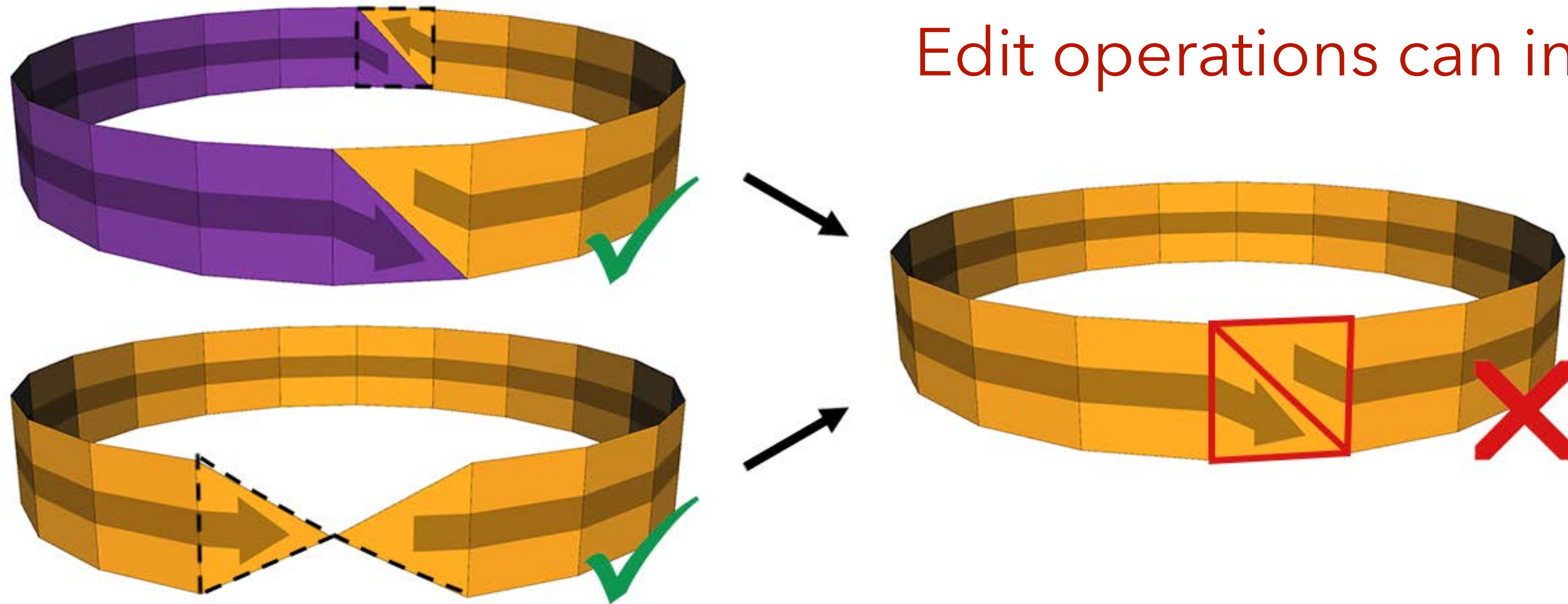

Our system *restricts* such edits but can still *span the space* of knittable stitch meshes of the same surface topology class.



# Edits can span the space of knittable shapes

Any valid augmented stitch mesh can be edited into a trivial knittable structure  
By a sequence editing operations, any valid knittable surface **in the same surface topology class** can be reached.

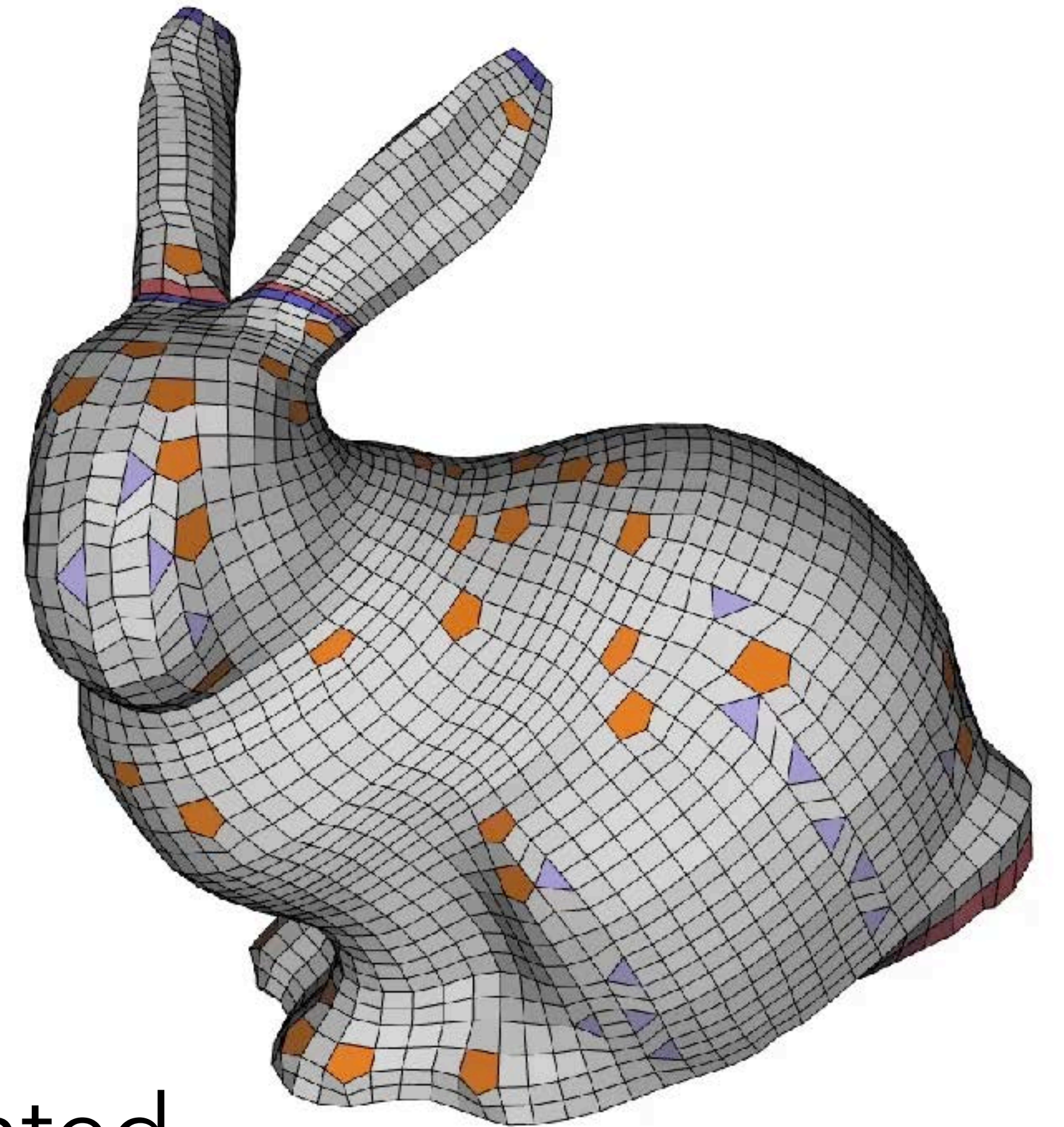

Our system can span the space of augmented stitch meshes using our editing operations

# Edits can span the space of knittable shapes

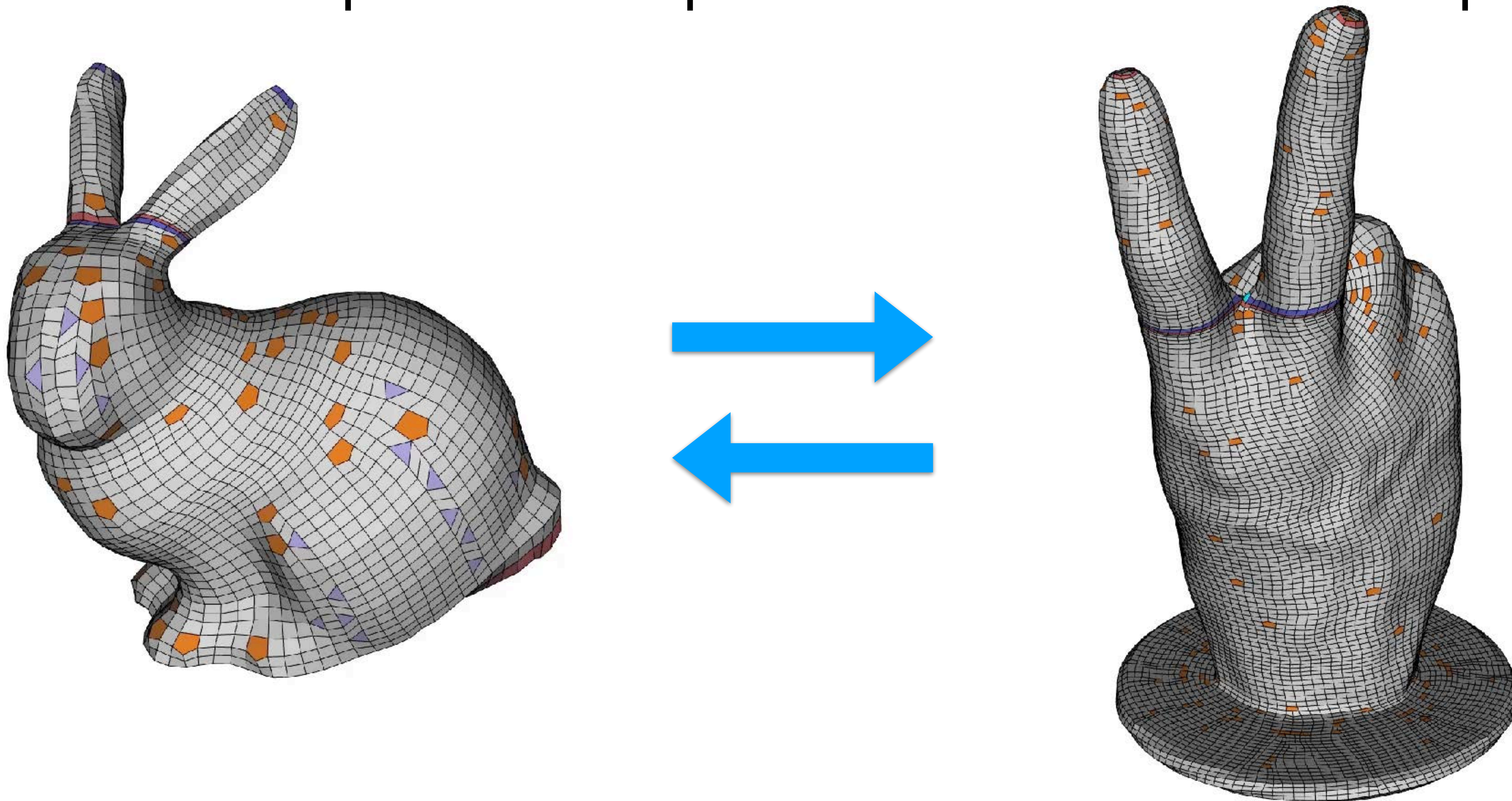

# Extending face types for multiple yarns

## Fair-Isle

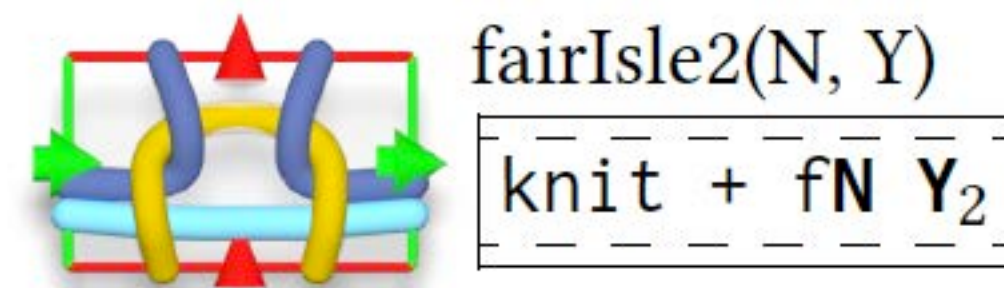
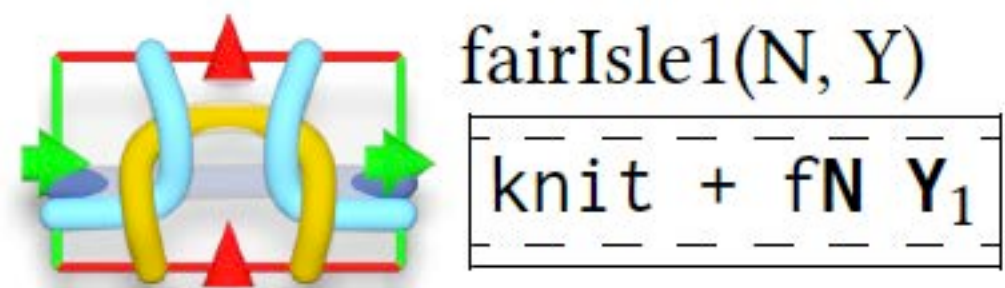

## Plating

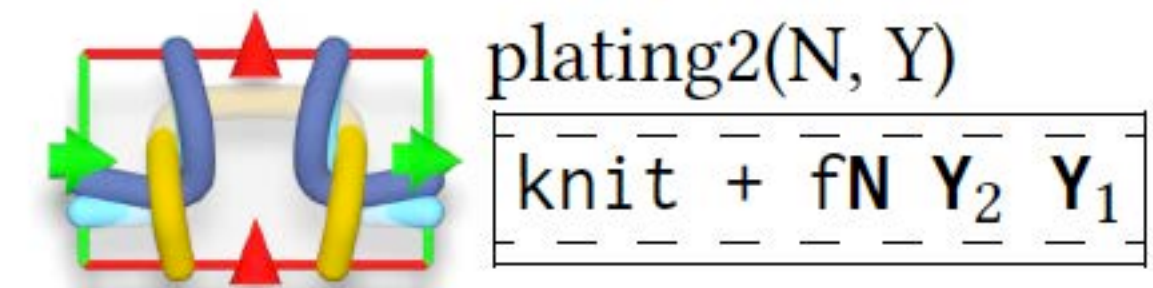
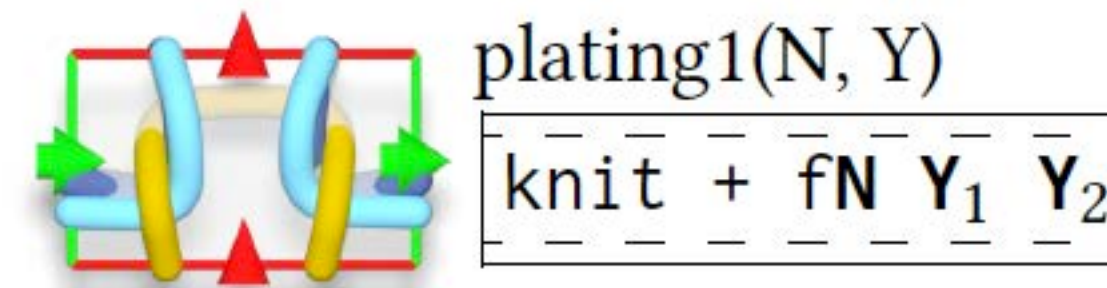

# Pipeline of our design system

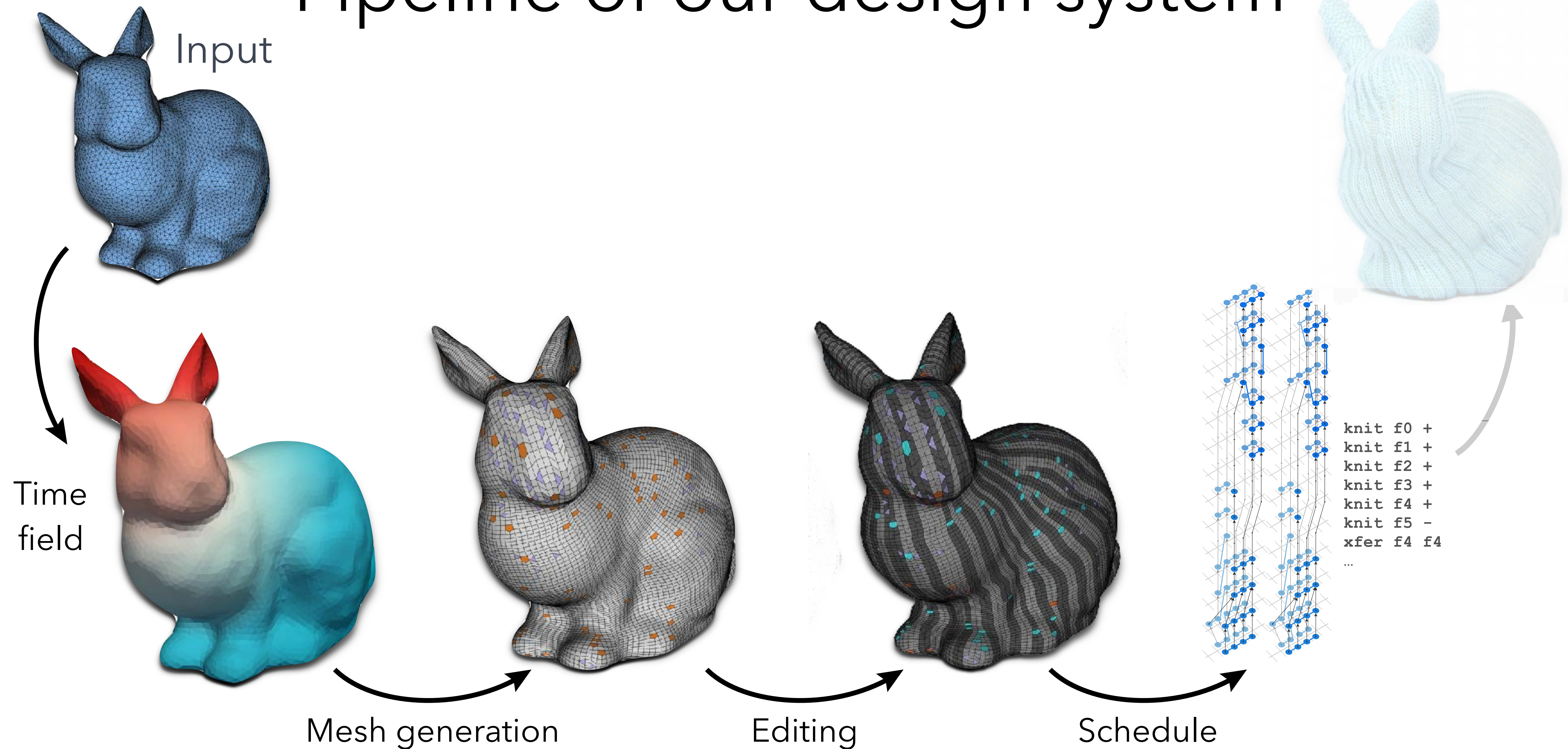

# Scheduling stitches on machine needles

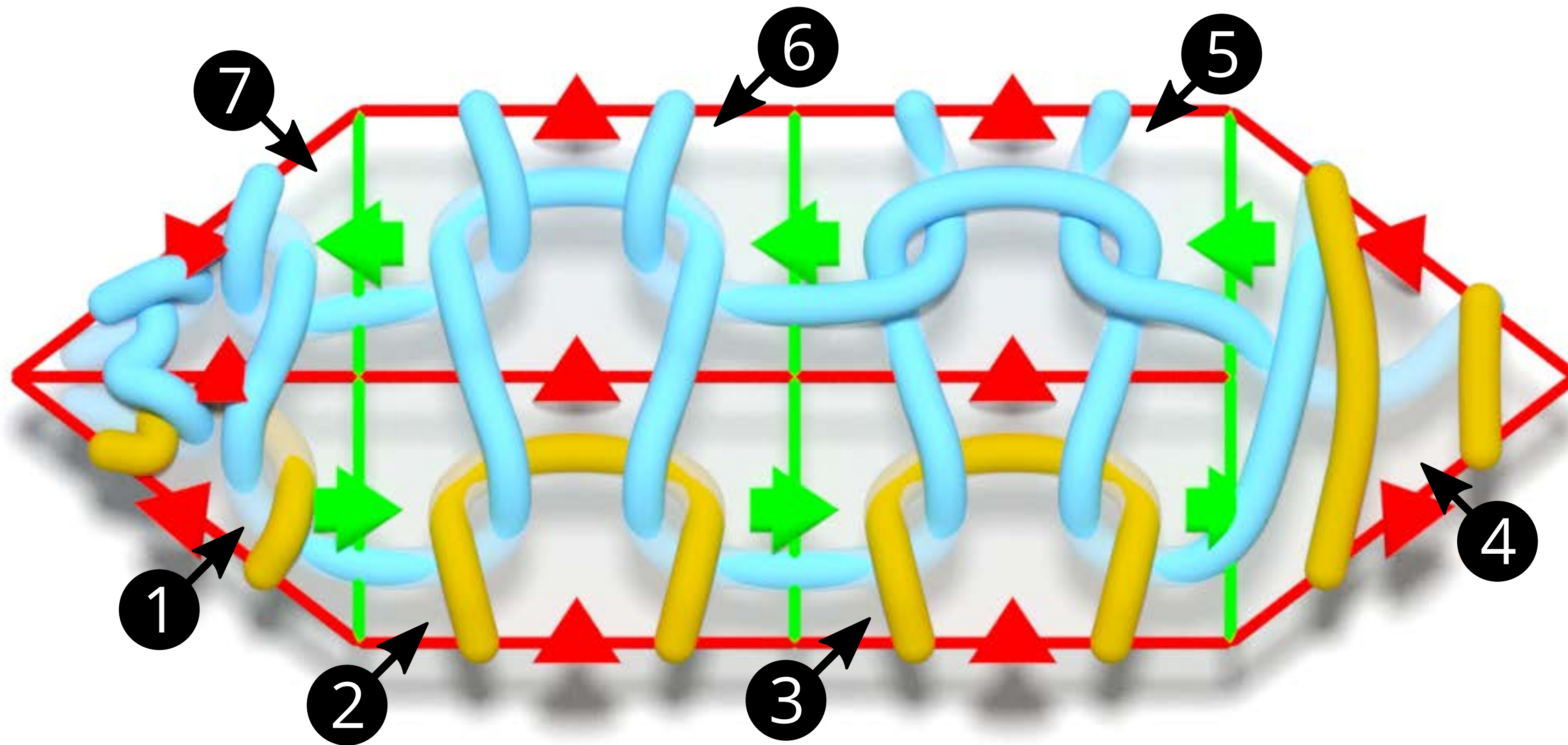

①	{	in A		
		knit +		A
②	{	knit +		A
③	{	knit +		A
④	{	tuck +		A
⑤	{	xfer		
		knit -		A
⑥	{	knit -		A
⑦	{	knit -		A
		out A		
	{	xfer		

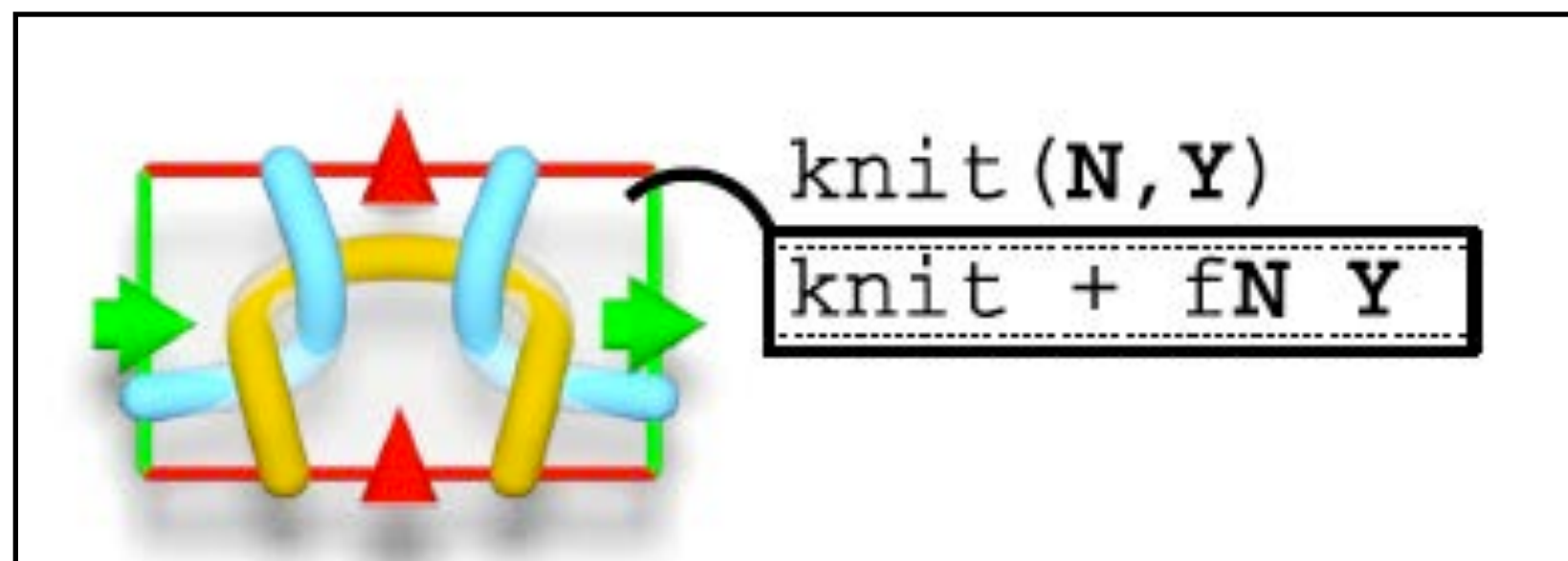

# Generating machine locations for face programs

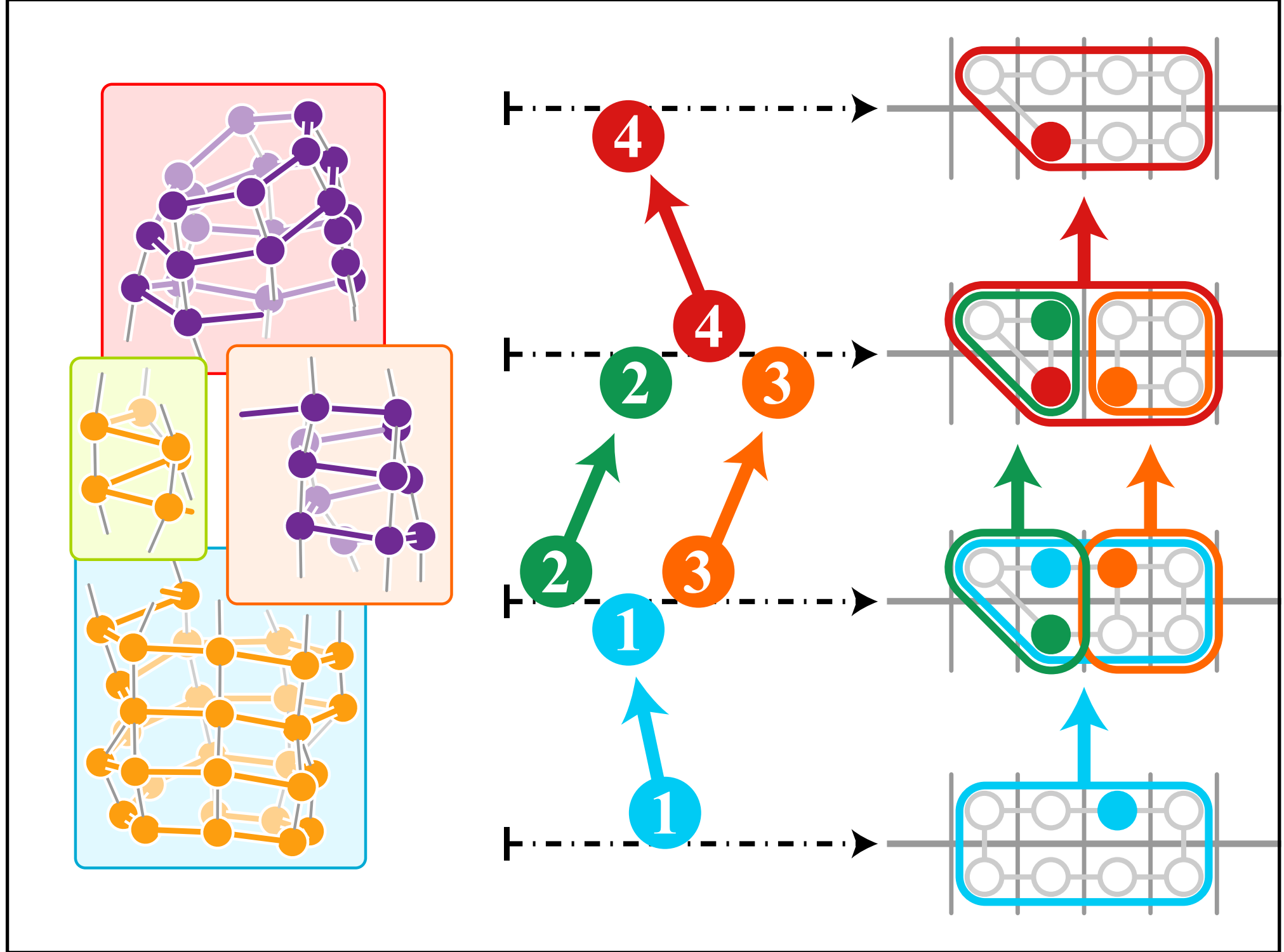
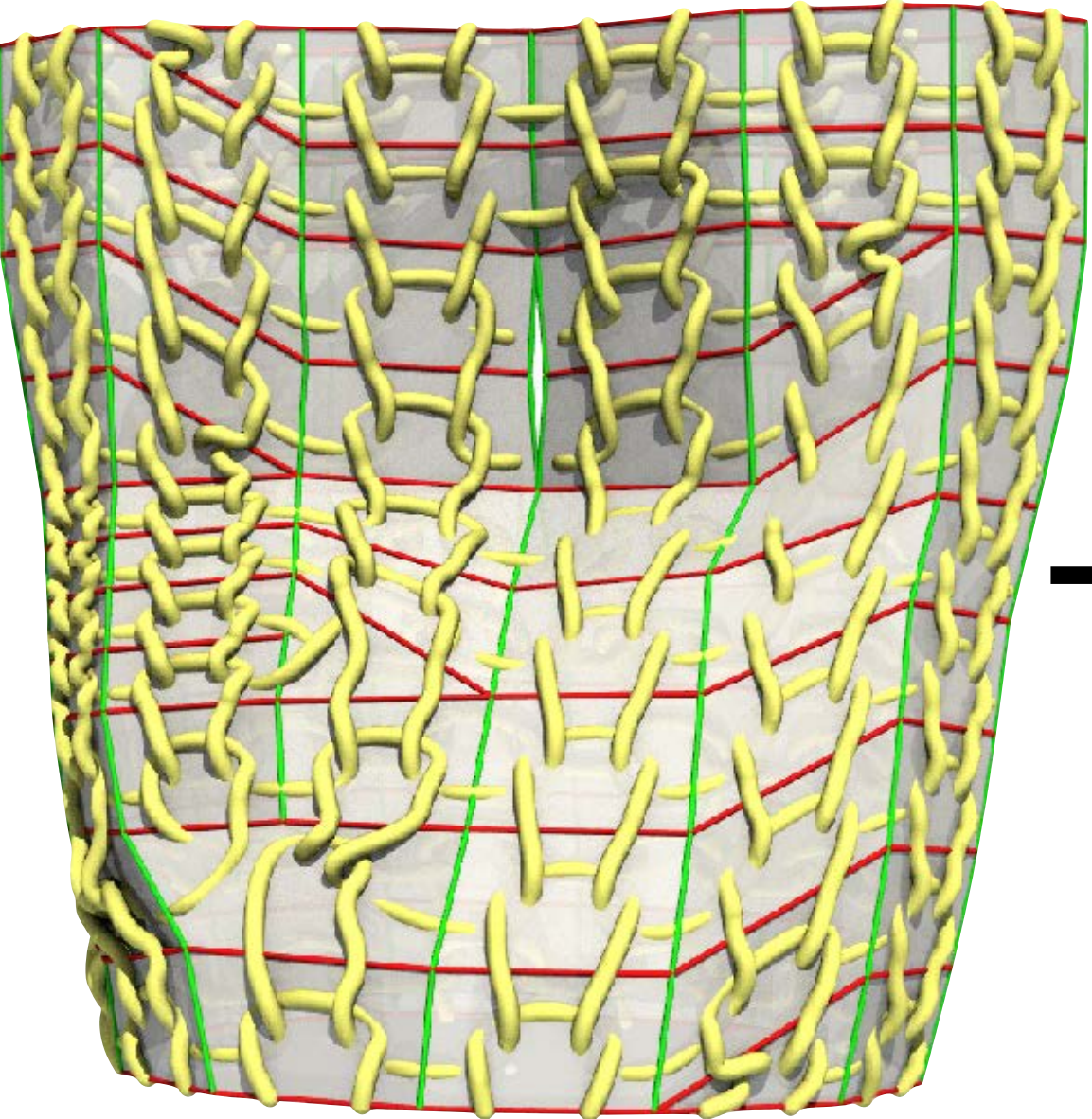

[Narayanan et al. '18]



```
knit f0 +
knit f1 +
knit f2 +
knit f3 +
knit f4 +
knit f5 -
xfer f4 f4
...
```

Interleave face programs

Convert complex faces into individual stitches

# Optimizing *passes* by instruction reordering

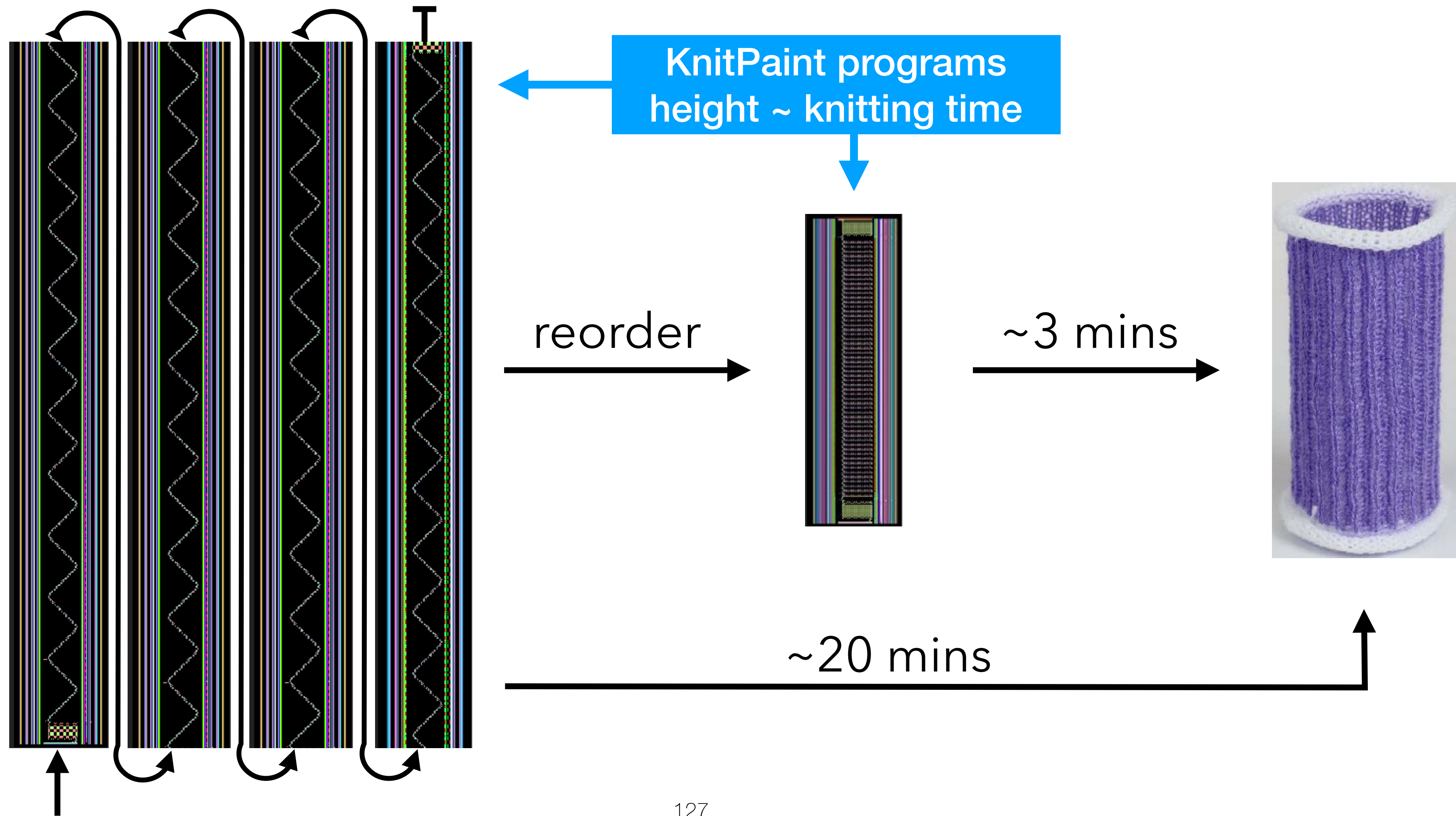

# Pipeline of our design system

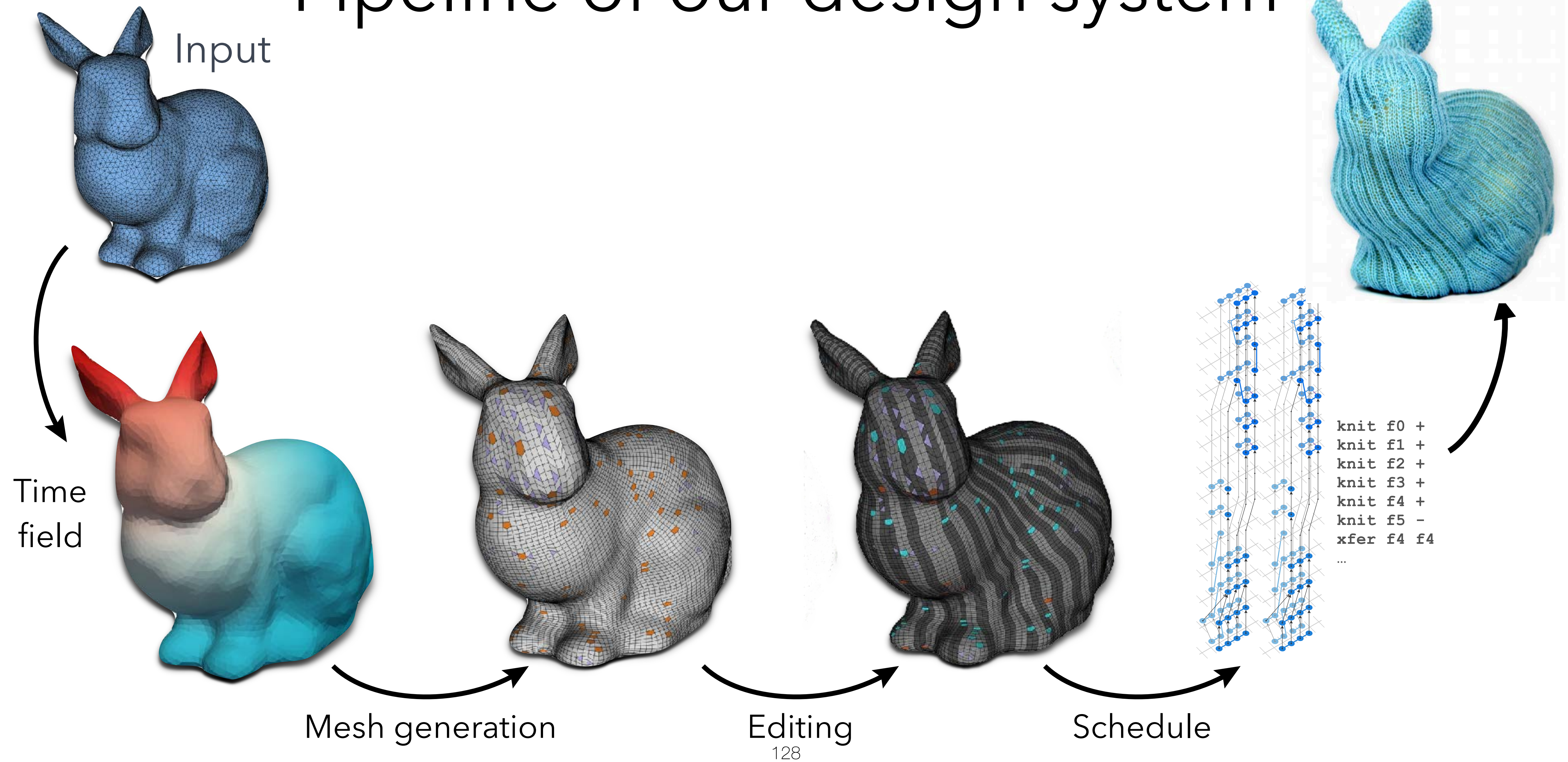



# All-knits vs textured Stanford bunny

[Narayanan et al. '18]



All knits, automatically generated



Textured with "knits" and "purls" by manually editing

# Visual Knitting Machine Programming

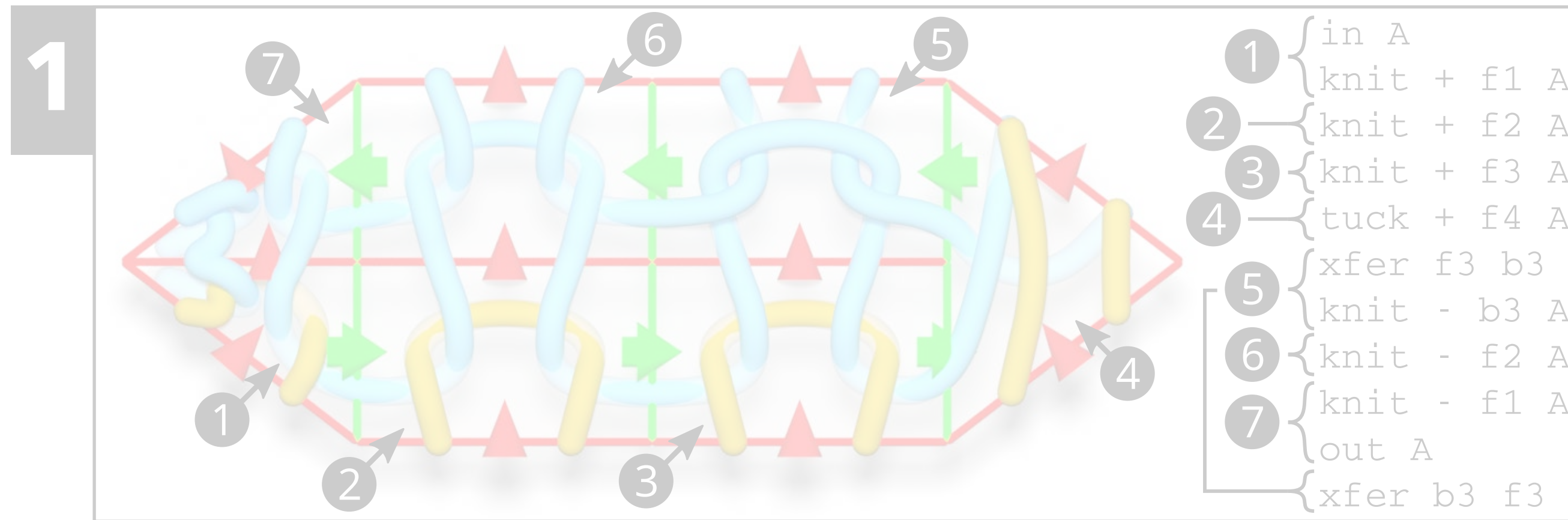

Augmented Stitch Mesh Representation

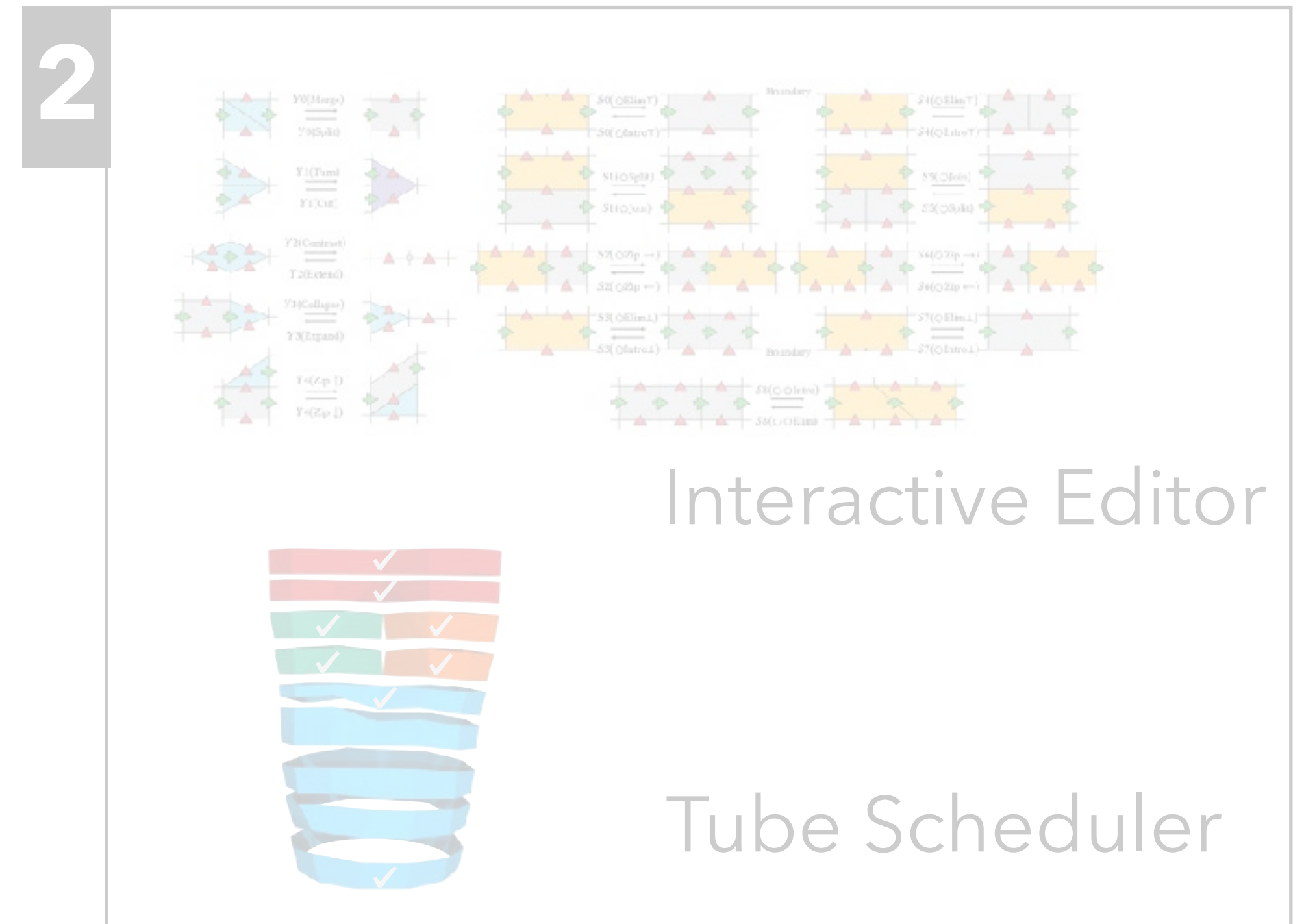

System

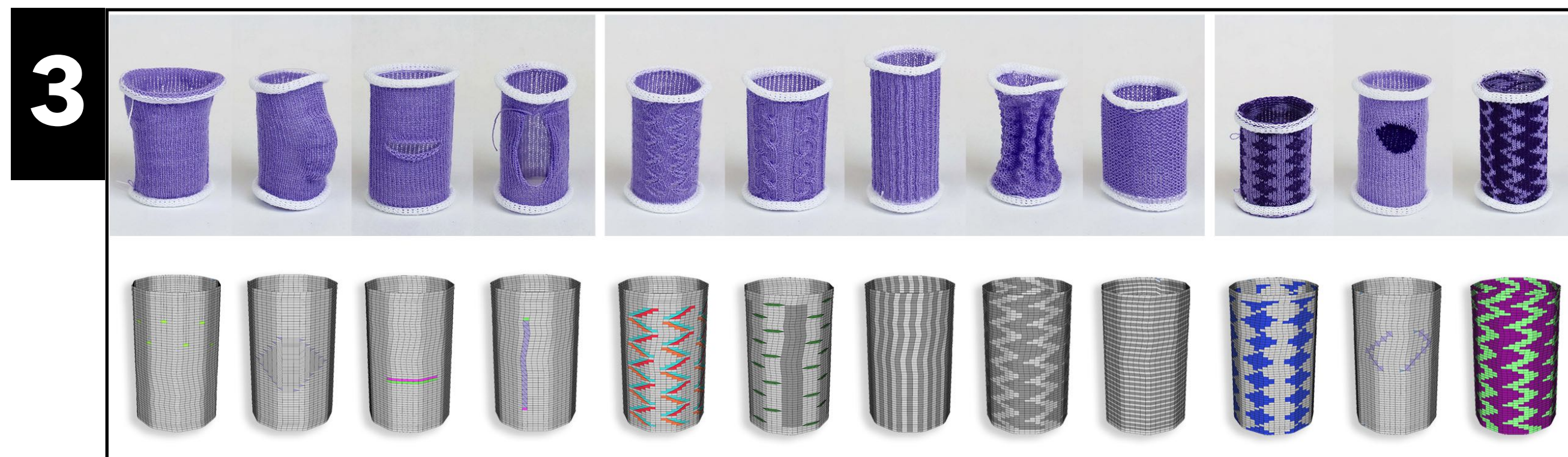

Results (Fabricated on a Shima Seiki V-bed whole-garment machine with 2/30 acrylic yarn)

# A Hand-warmer with cables and textures



Knitting ~10 mins  
131

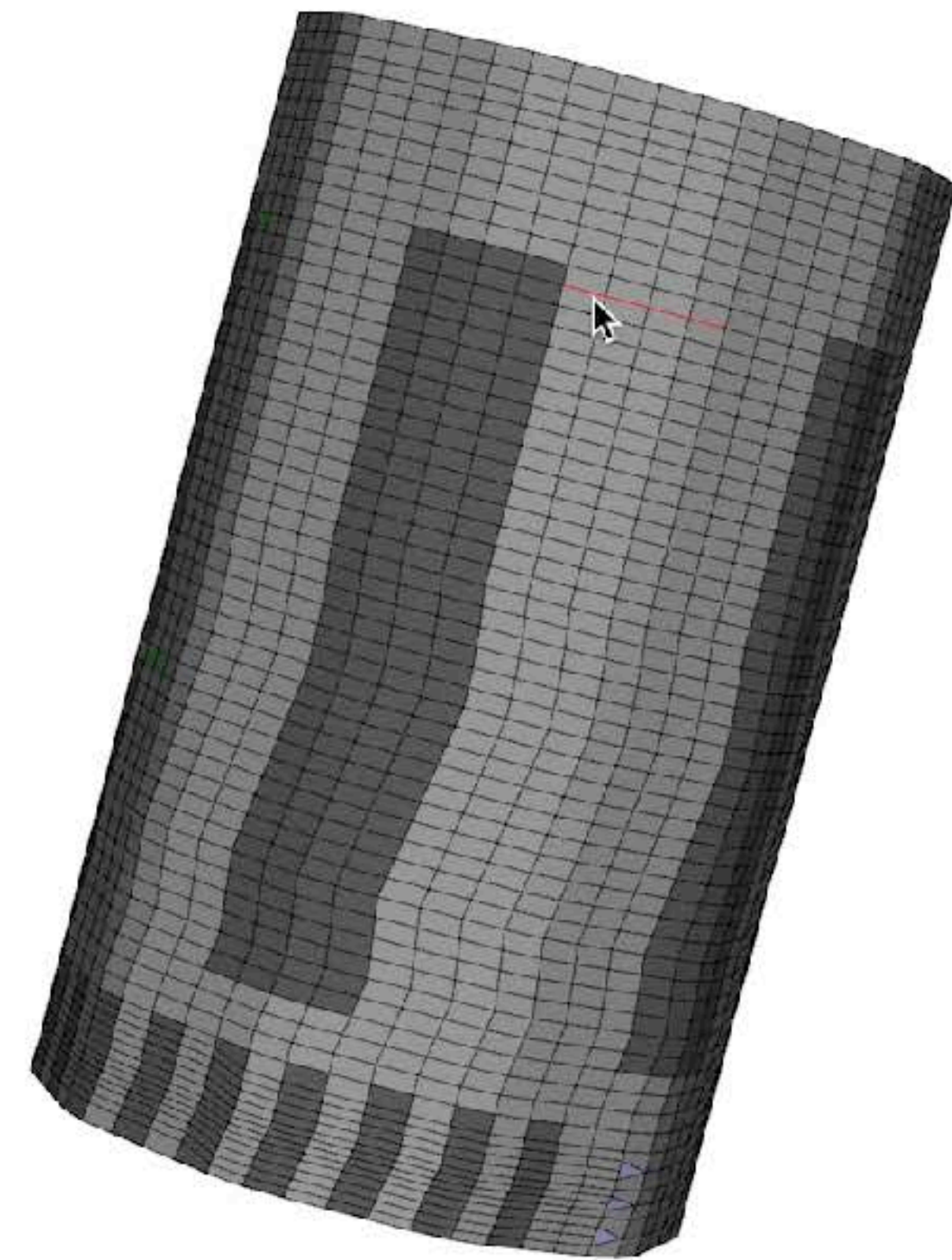

Editing ~15 mins

# Same mesh w/ multiple styles



Knitting ~35 mins

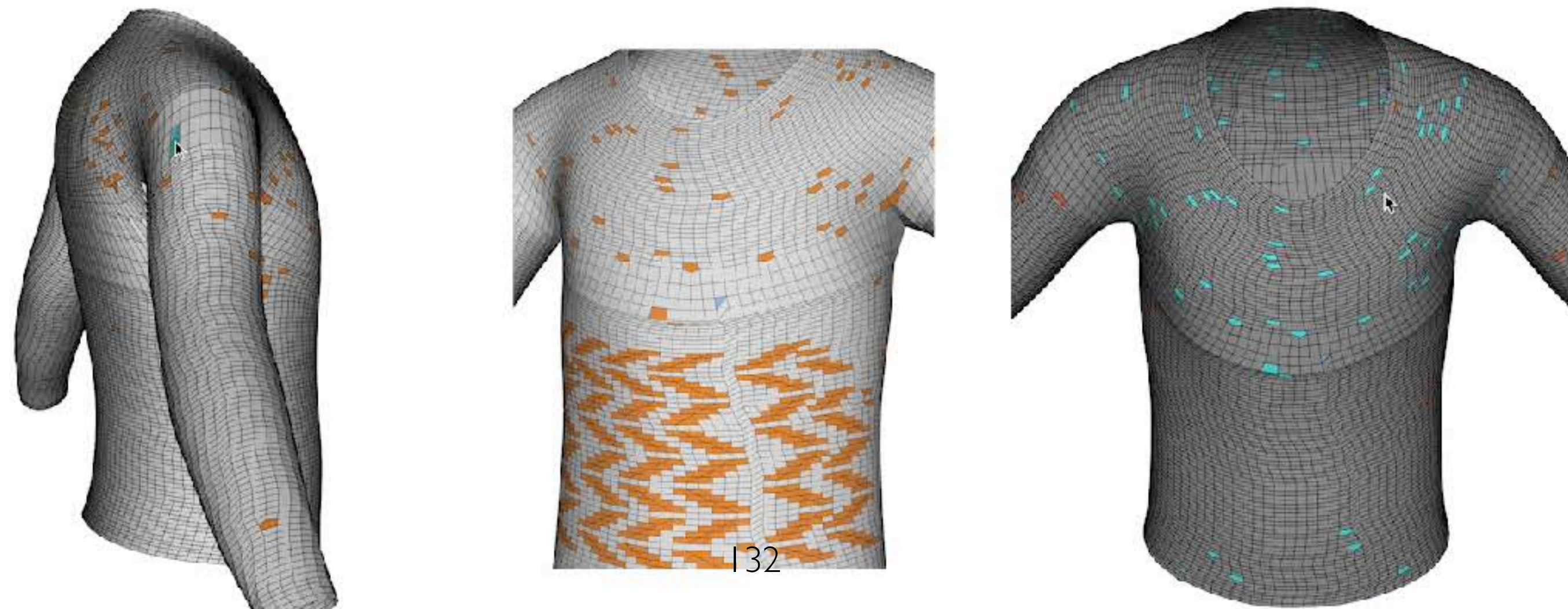

Editing ~15 mins

# Plating an image



Knitting ~20 mins



Editing ~1 mins

# Custom accessories

Knitting ~20 mins

Editing ~5 mins



Knitting ~25 mins

Editing ~60 mins

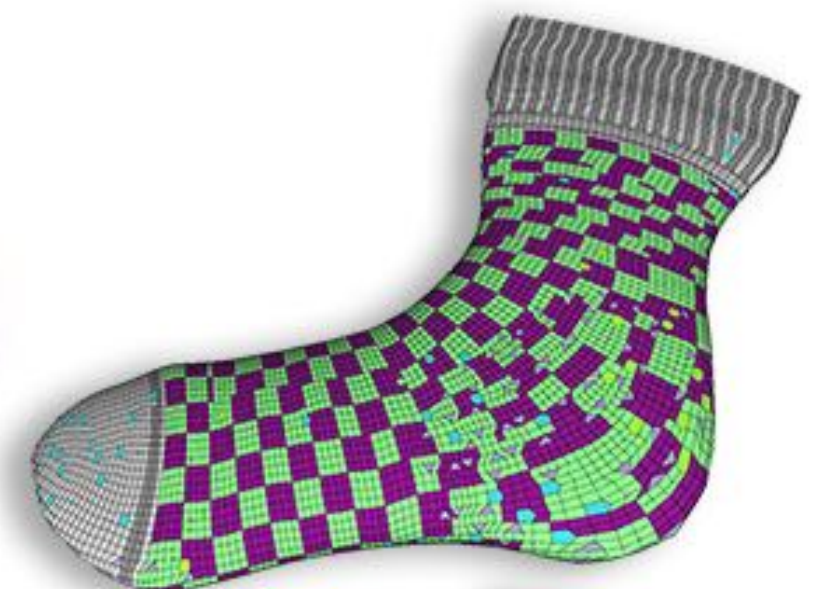

# Integrating conductive varn



# Visual Knitting Machine Programming

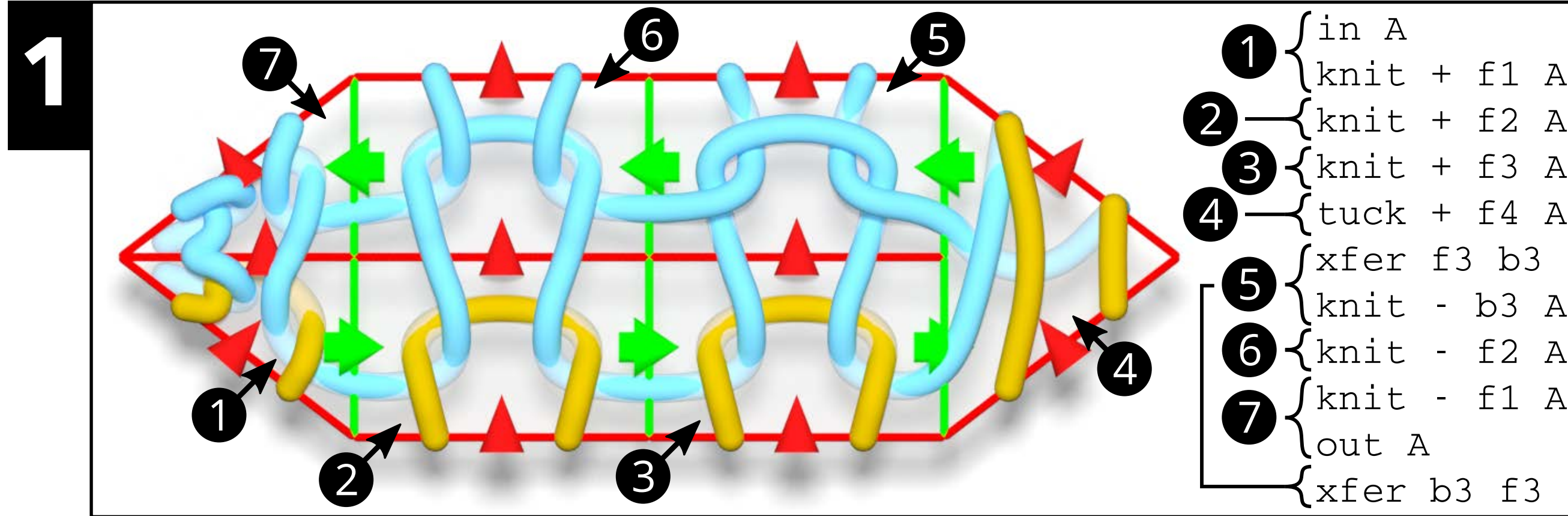

Augmented Stitch Mesh Representation

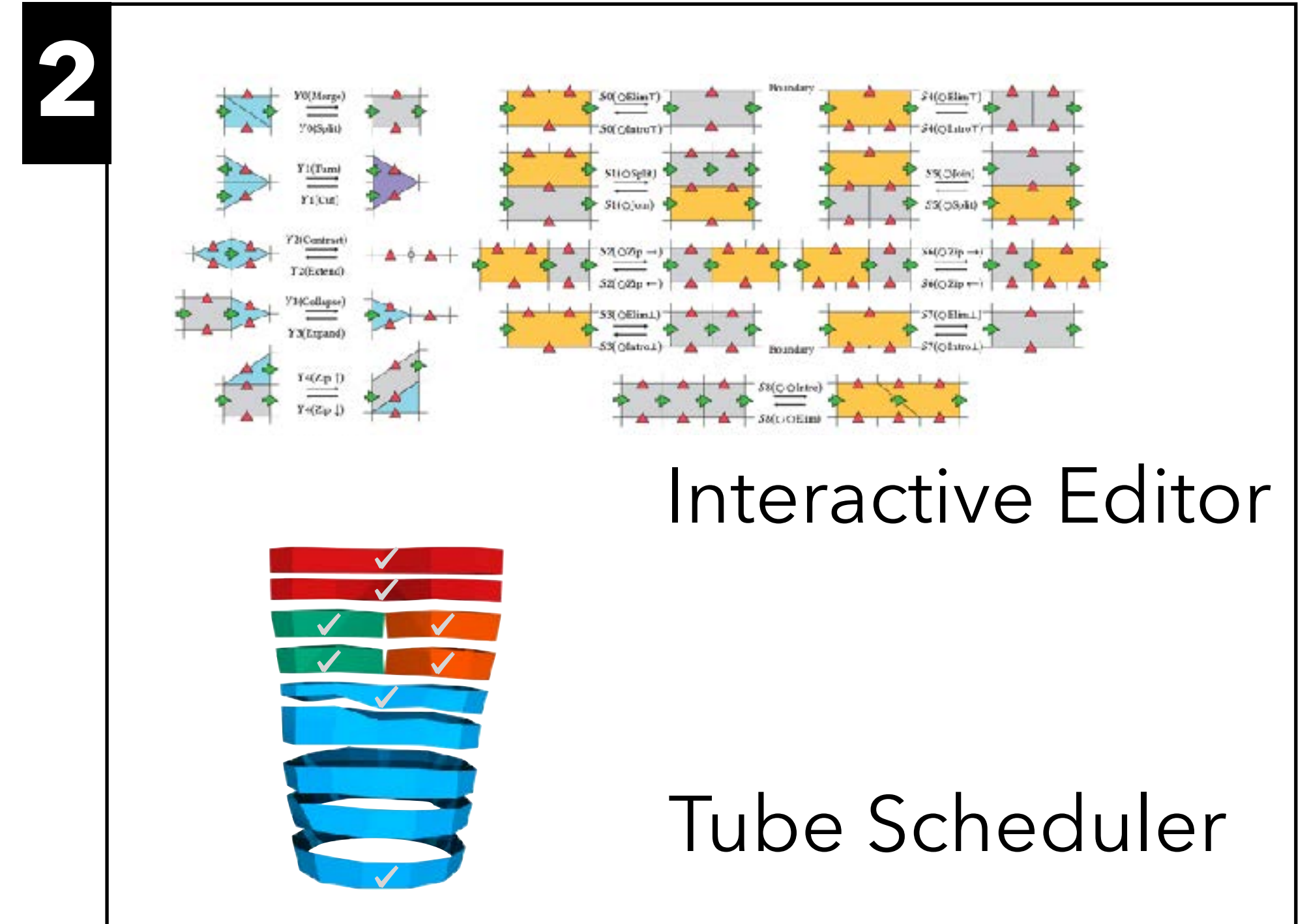

System

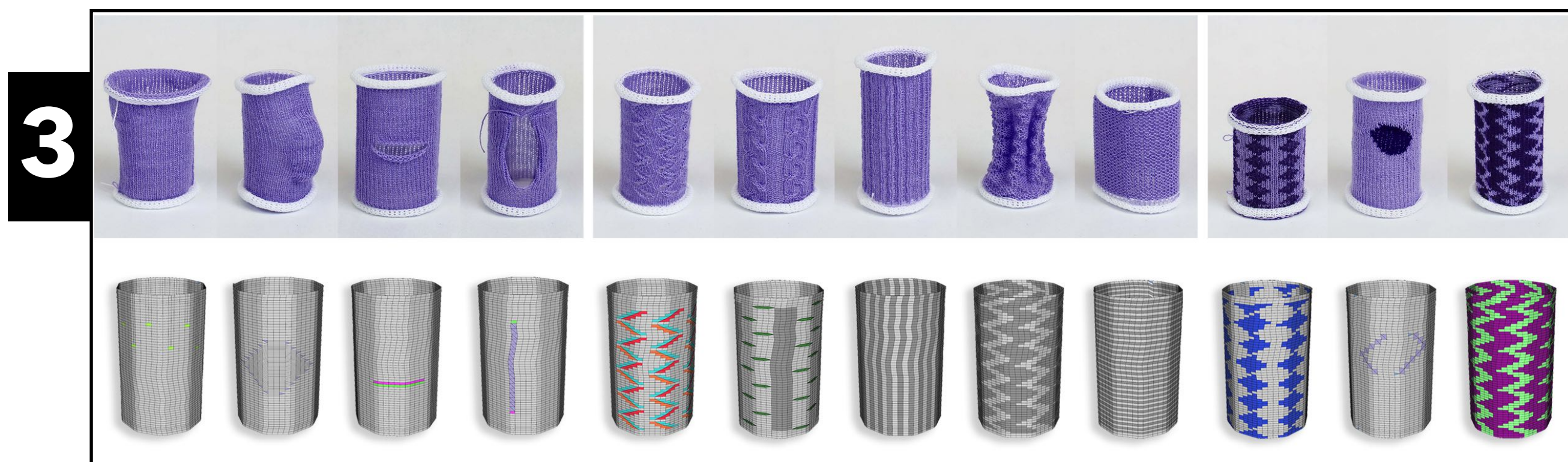

Results



# What can we do next with machine knitting?

## Predictive Simulation

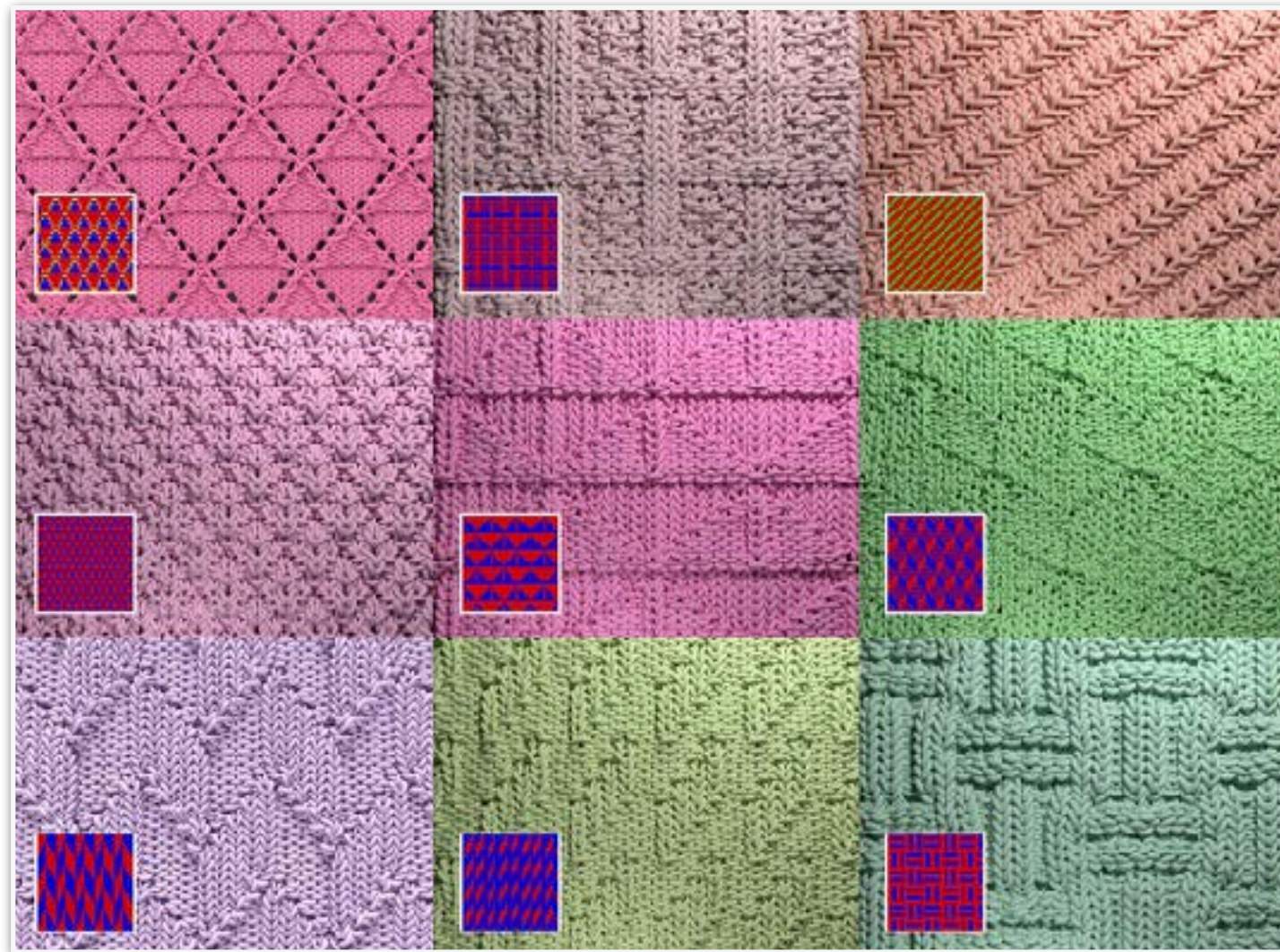

[Leaf et al. '18]

[Jiang et al. '17]

[Cirio et al. '14]

[Kaldor et al. '08]

# What can we do next with machine knitting?

## Predictive Simulation

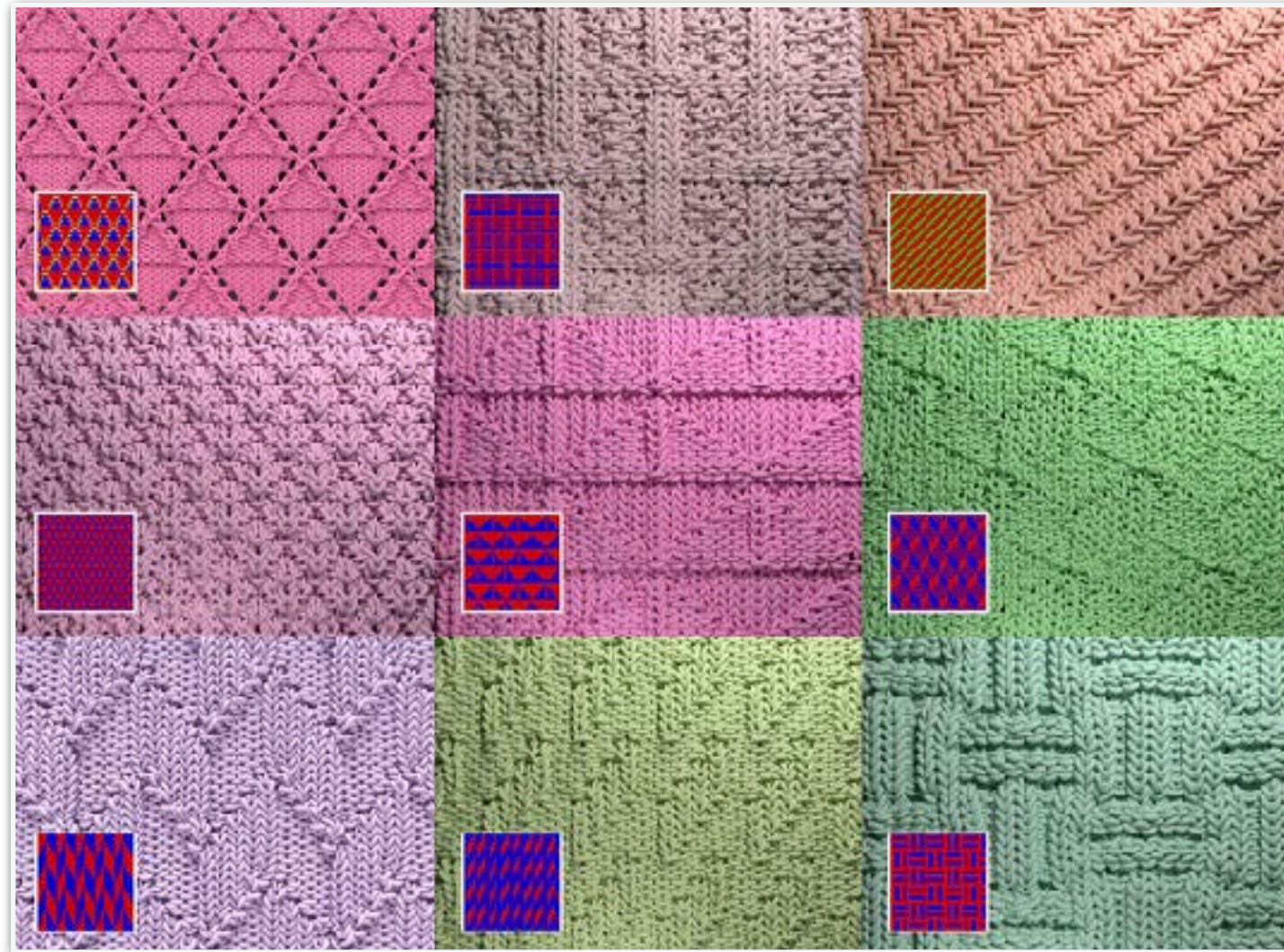

[Leaf et al. '18]  
[Jiang et al. '17]  
[Cirio et al. '14]  
[Kaldor et al. '08]

## Calibration

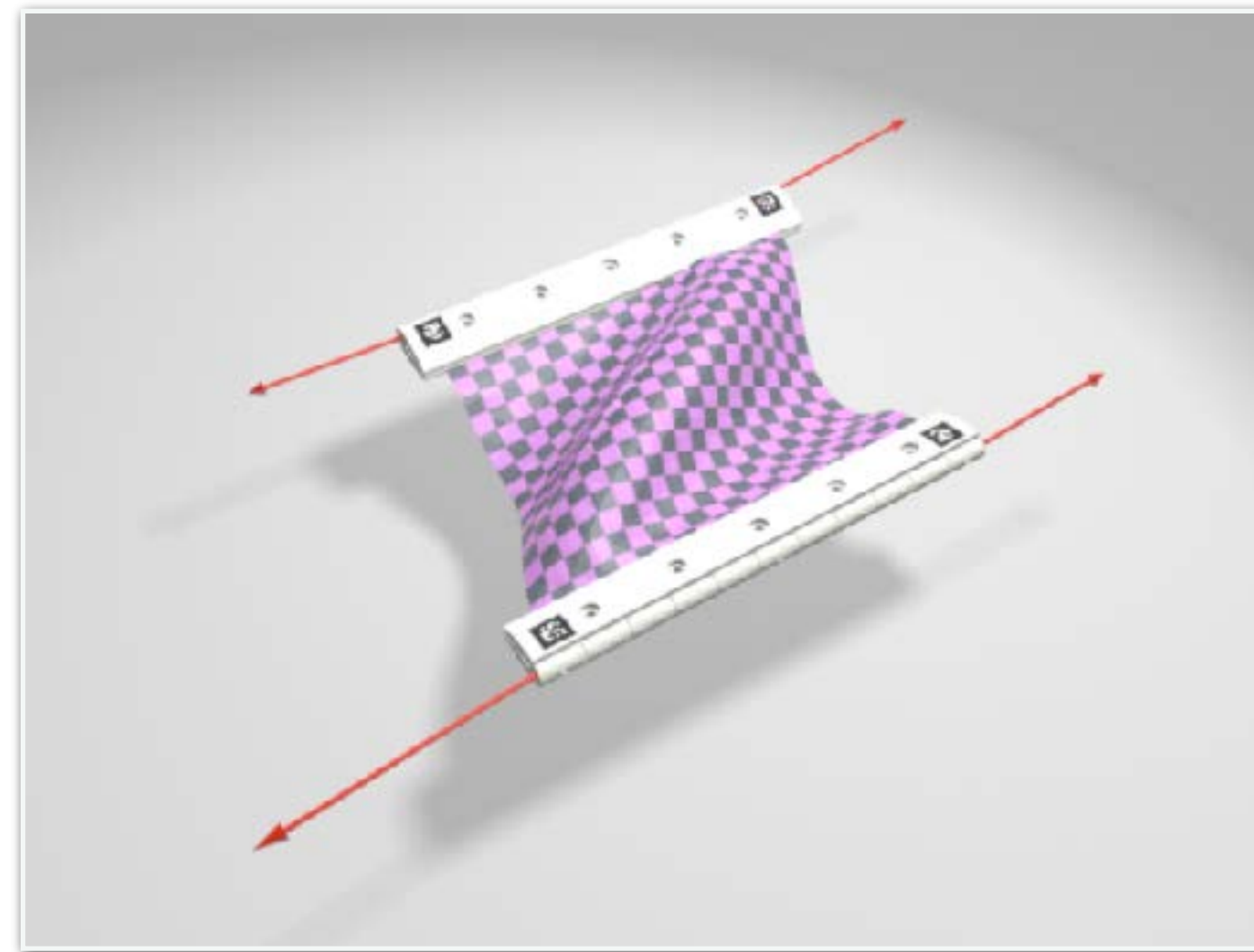

[Miguel et al. '12]  
[Wang et al. '11]

# What can we do next with machine knitting?

## Predictive Simulation

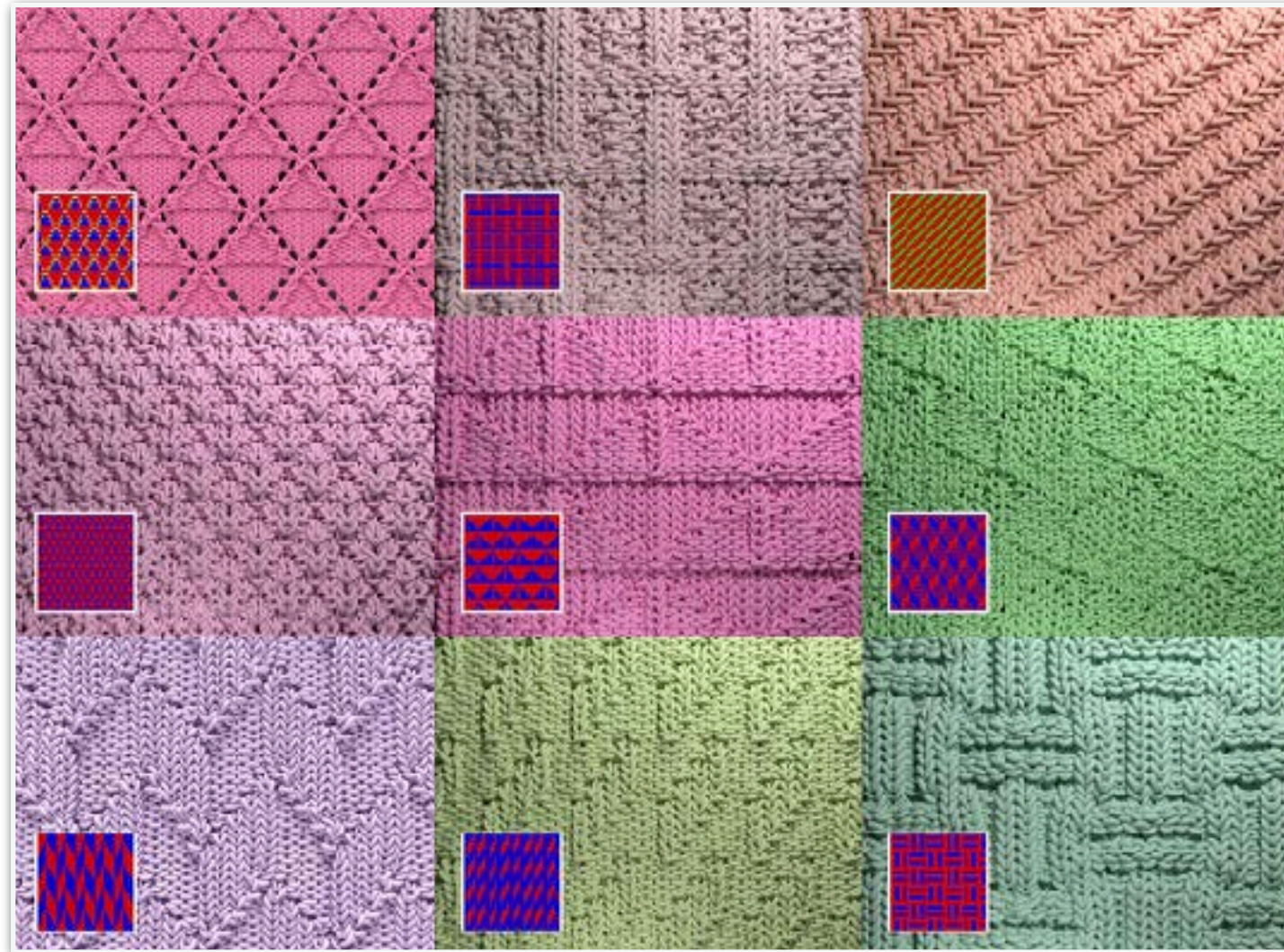

[Leaf et al. '18]  
[Jiang et al. '17]  
[Cirio et al. '14]  
[Kaldor et al. '08]

## Calibration

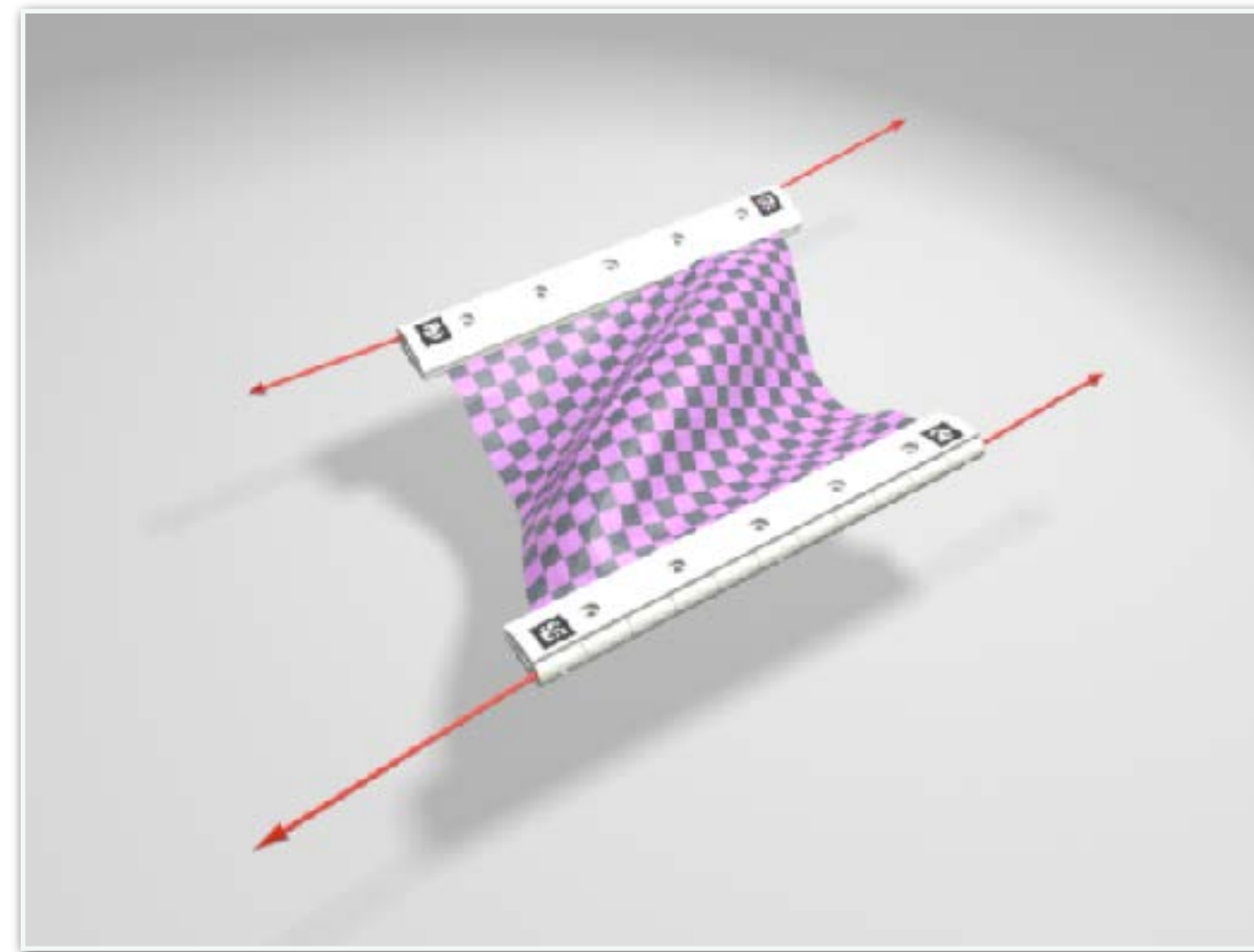

[Miguel et al. '12]  
[Wang et al. '11]

## Applications



[Pavko-Čuden et al. '17]  
[Knittel et al. '15]  
[Alderson et al. '12]  
[Hu et al. '11]

# What can we do next with machine knitting?

Predictive Simulation

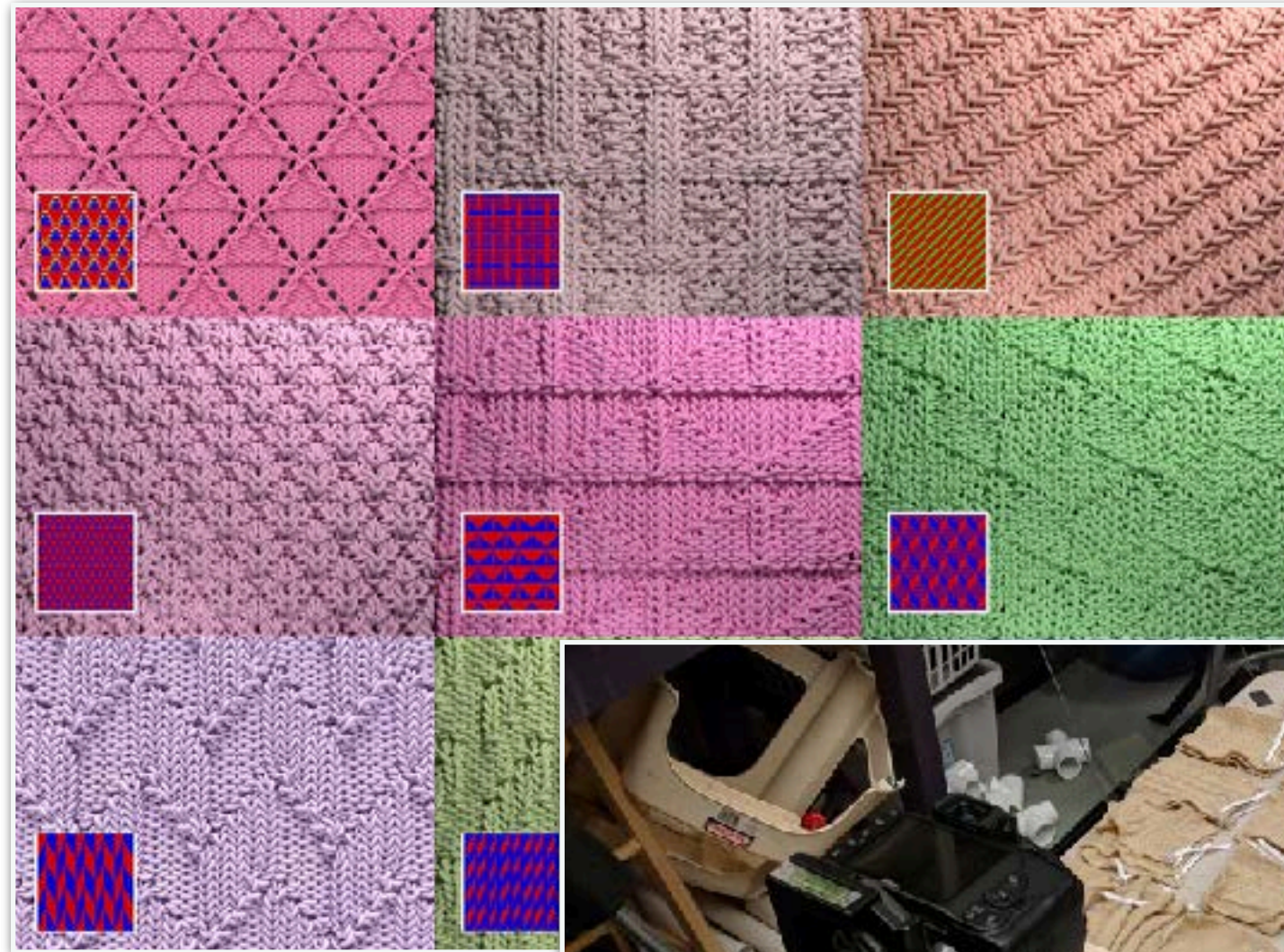

Calibration

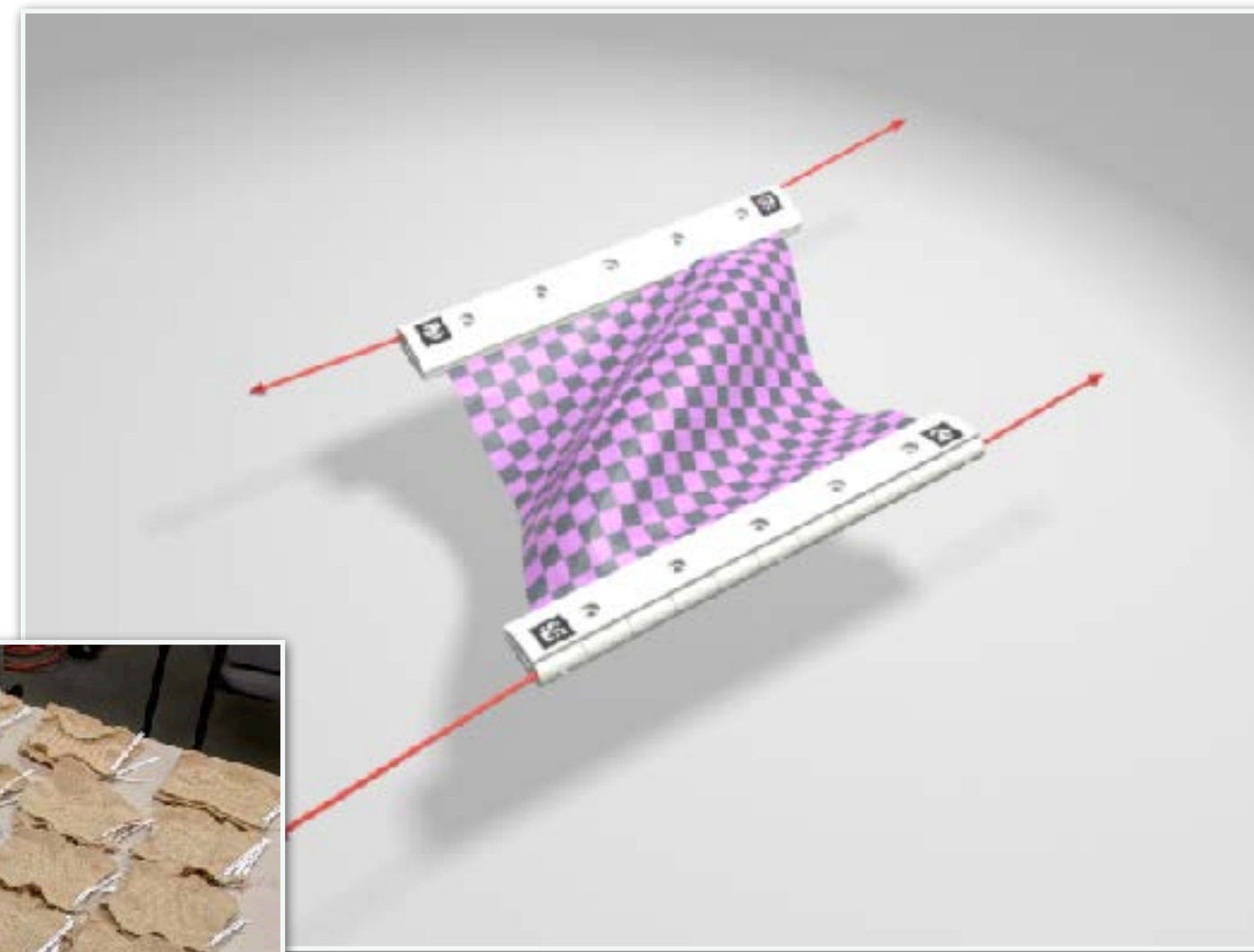

Applications



## Datasets

<http://db.knit.zone/> [Hofmann et al.'19]

<http://deepknitting.csail.mit.edu/dataset/> [Kasper et al.'19]



contact:  
[kuiwu@csail.mit.edu](mailto:kuiwu@csail.mit.edu)

**Thank You! Questions ?**